

CONVERTIBLE TOP

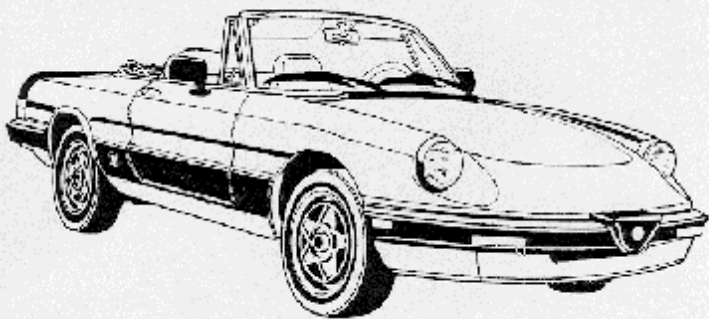

Alfa Romeo



CarDisc International, Ltd.

© Copyright 2004

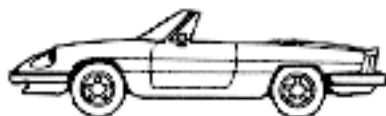

TABLE OF CONTENTS

INTRODUCTION	5
TOP ADJUSTMENTS	6
Window Height	6
Window/Side Flap Fit	9
Weather Stripping	10
Vent Frame Alignment	12
Reassembling Door Hardware	12
Top Piping/Windshield Bow Fit	13
Latching Top	13
Chafe Marks	14
TOP REMOVAL	15
Removing Edge Guide	15
Removing Retainer Strips	15
Removing Top from Frame Side Supports	16
Removing Cables from Turnbuckles	16
Removing Fabric Overlays	18
Removing Front Corner Bolts	18
Removing Top from Front of Frame	19
Removing Cables	20
Cleanup and Inspection	20
TOP INSTALLATION	21
Installing Cables	21
Installing Front of Top	22
Installing Front Gasket and Retainer	24
Attaching Top to Rear Water Channel	25
Gluing Fabric Overlays to Crossmembers	26
Attaching Top to Side Supports	28
Attaching Front Corners of Top	29
Securing Retainer Strips	31
Reassembling Turnbuckles	32
Adjusting Cable Tension	32
Attaching Edge Guide	32
NOTES AND CAUTIONS	34



INTRODUCTION

This publication is intended for use by Alfa Romeo dealers and service technicians. It contains explanations of procedures used in adjusting, servicing, removing, and installing convertible tops on both the Graduate and the Spider Veloce. Procedures are identical and are fully illustrated to ensure proper identification of components, tools, and recommended service procedures.

NOTE: The Graduate has a vinyl top that is vulcanized to the rear window. The Spider Veloce is fitted with a canvas top with the rear window sewn in.

1. Top piping
2. Side flap
3. Vent frame
4. Chrome edge guide

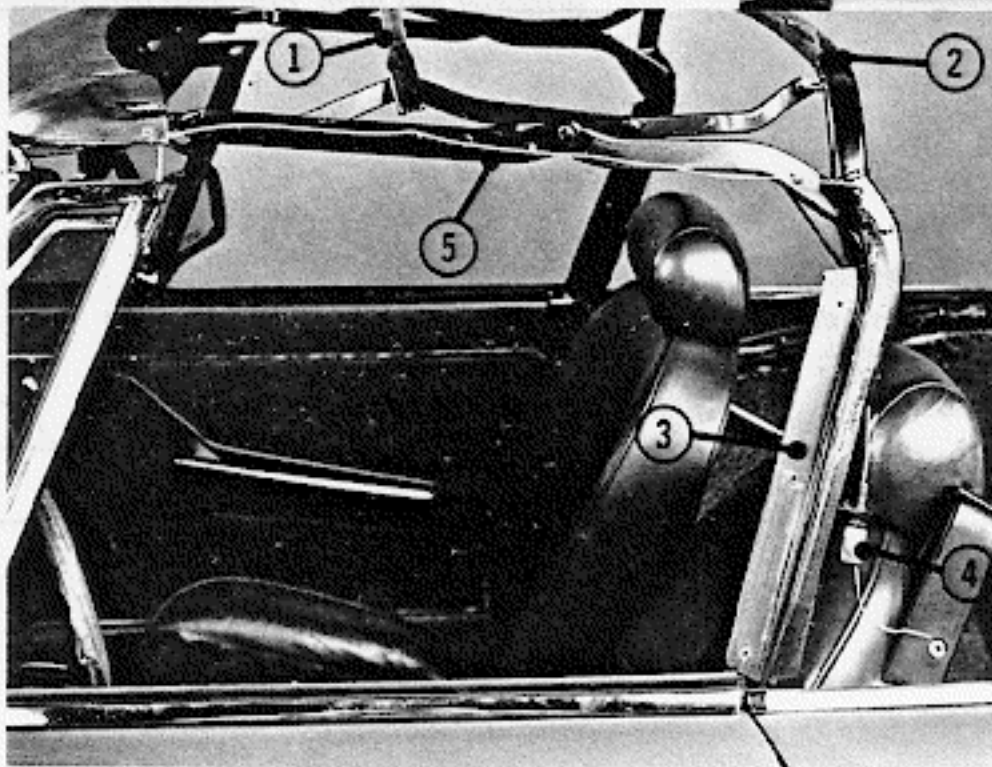
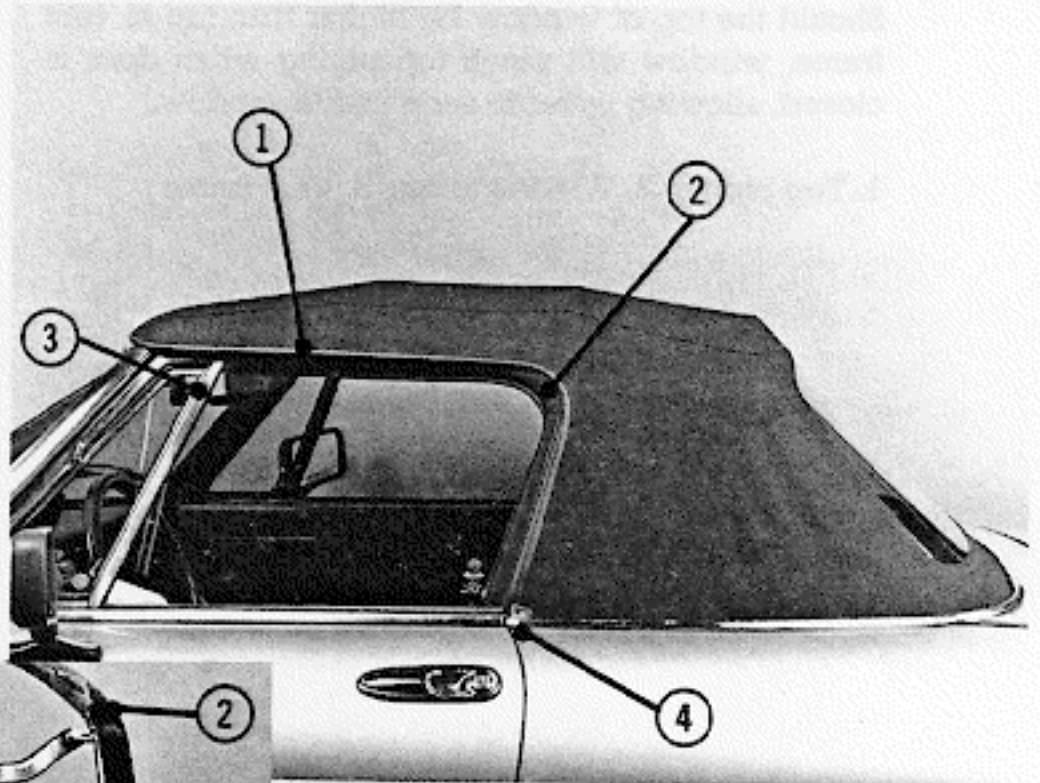

1. Front crossmember
2. Main crossmember
3. Frame side support
4. Turnbuckle
5. Cable

TOP ADJUSTMENTS

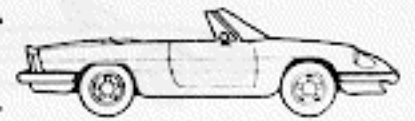

Should there be a wind or water leakage problem, first check condition of weather stripping, vent frame, vent frame/window alignment, and fit of top before considering top replacement.

Window Height

Should the top of window be higher than top of vent frame, window will pinch top piping when door is closed, allowing water to seep inside window.

1. Top piping
2. Window glass
3. Vent frame

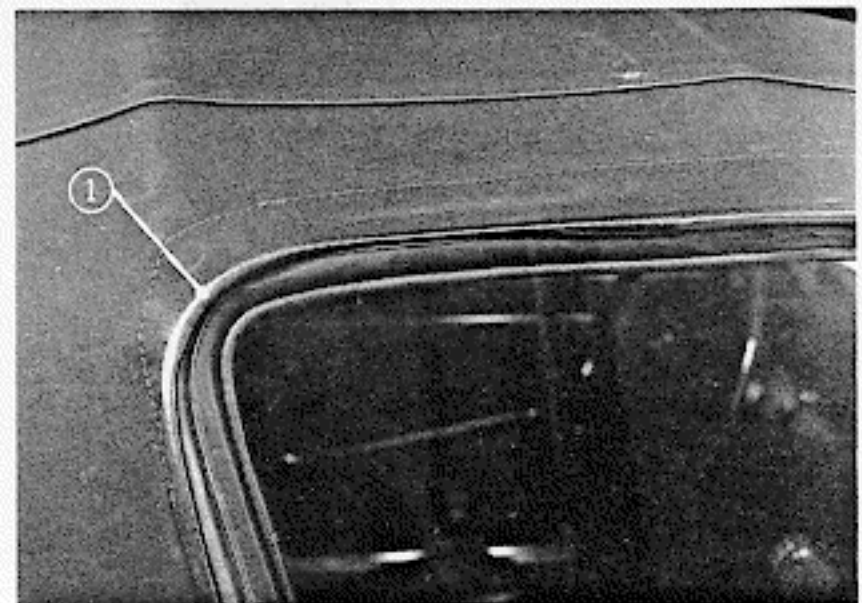
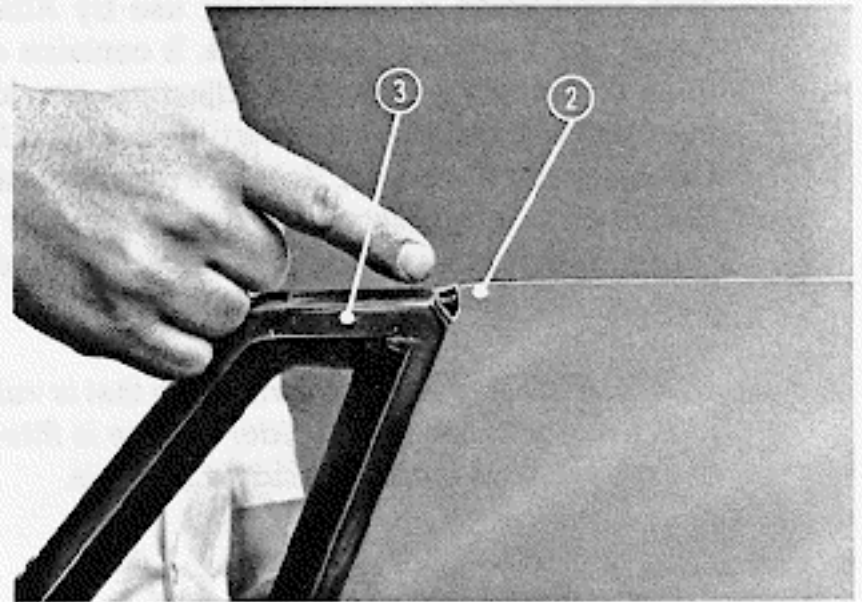

Window too high, pinching top piping.

Height of window is controlled by window stops. By loosening 10 mm nuts securing stops to windows, stop brackets and rubber stoppers can be adjusted up or down to change height and angle of window.

1. Window stops

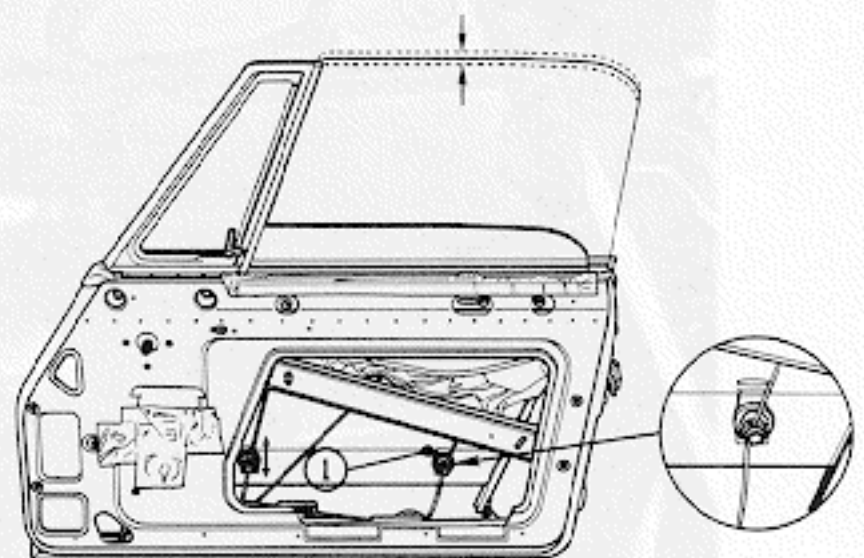

Window height adjustments.



INTRODUCTION

This publication is intended for use by Alfa Romeo dealers and service technicians. It contains explanations of procedures used in adjusting, servicing, removing, and installing convertible tops on both the Graduate and the Spider Veloce. Procedures are identical and are fully illustrated to ensure proper identification of components, tools, and recommended service procedures.

NOTE: The Graduate has a vinyl top that is vulcanized to the rear window. The Spider Veloce is fitted with a canvas top with the rear window sewn in.

1. Top piping
2. Side flap
3. Vent frame
4. Chrome edge guide

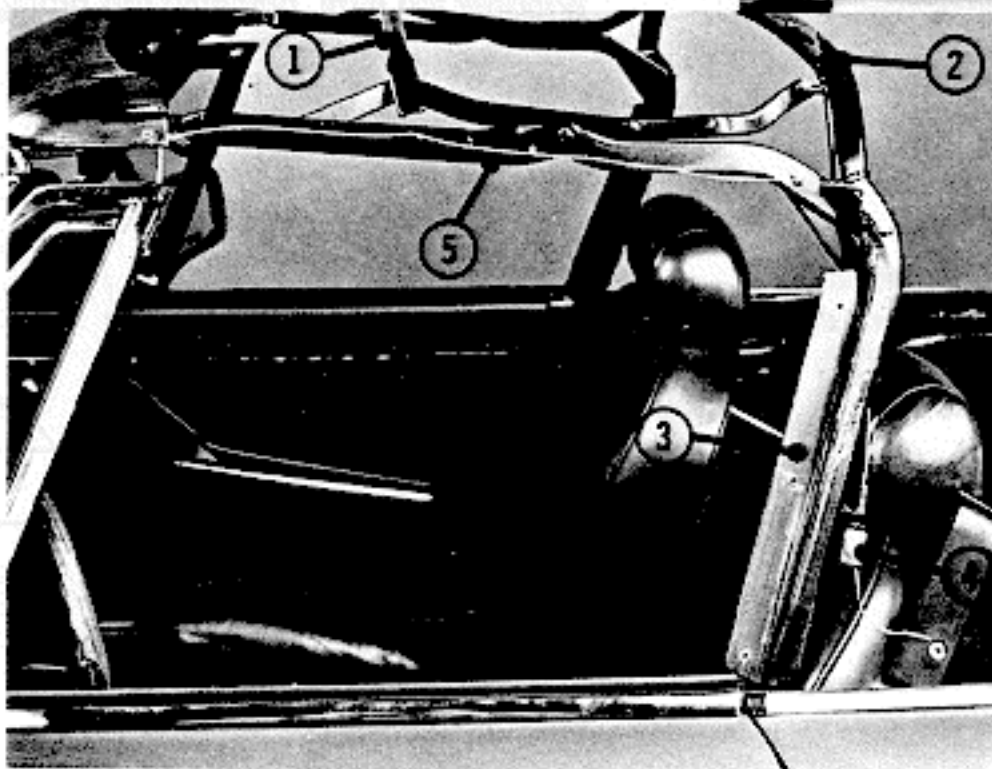
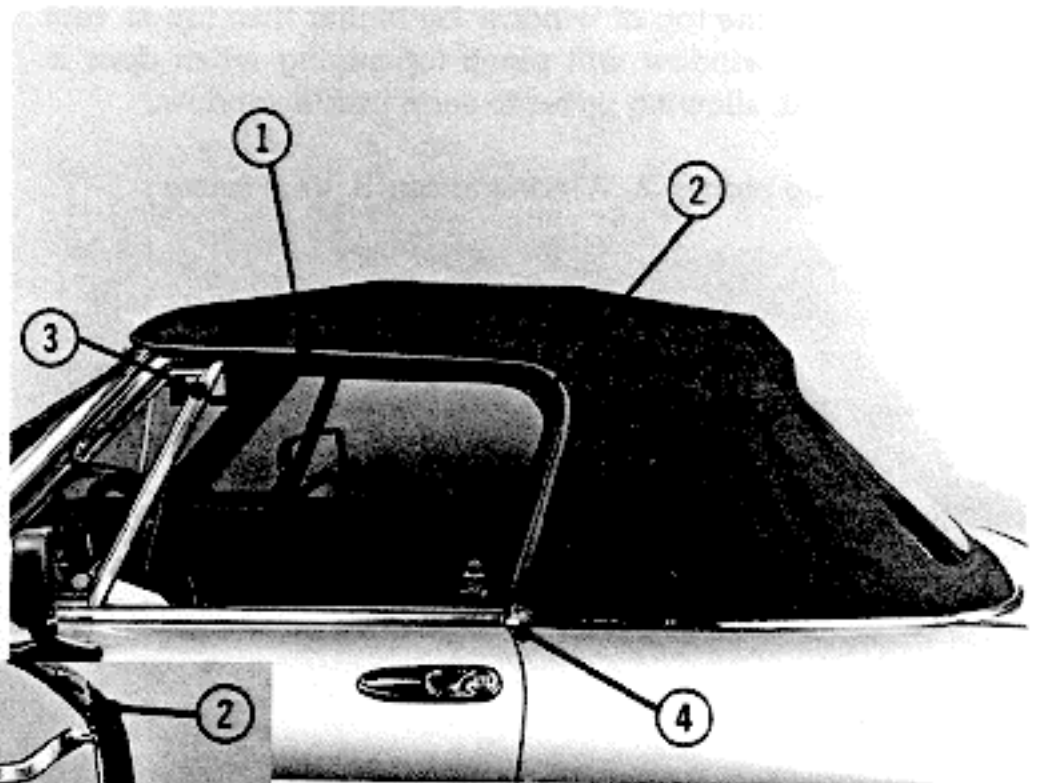

1. Front crossmember
2. Main crossmember
3. Frame side support
4. Turnbuckle
5. Cable

TOP ADJUSTMENTS

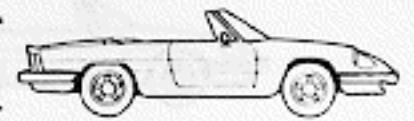

Roll up plastic water skirt and tuck it above large access opening in door.

Lower window and inspect two window stops. Improper window height may be result of rubber stopper missing from stop bracket. If so, replace stopper.

1. Window stops

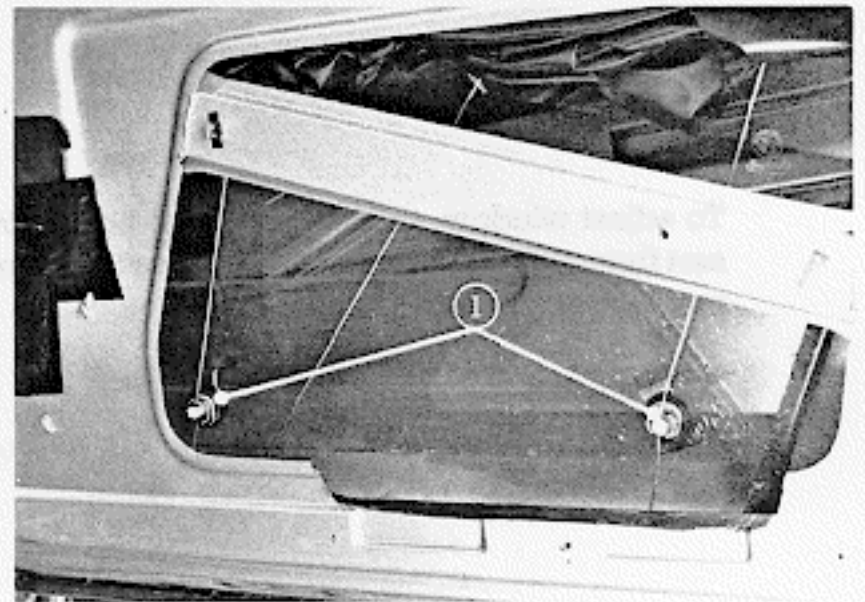

Window stops.

If stop bracket is not straight, loosen 10 mm bolt and nut and straighten stop bracket. Retighten 10 mm nut and bracket.

1. Stop bracket 2. Rubber stopper 3. 10 mm nut 4. Window cable

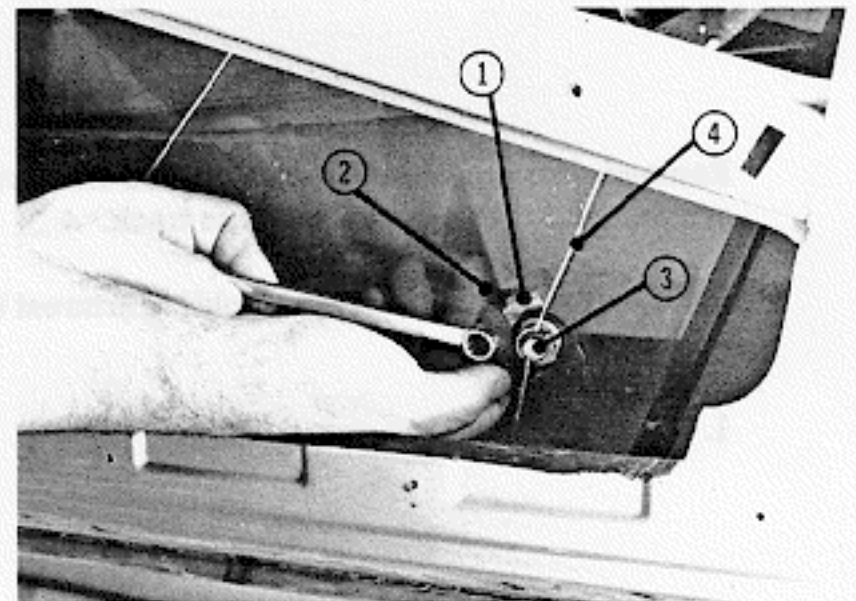

Repositioning stop bracket.



TOP ADJUSTMENTS

Adjust stop brackets up or down until window is level with top of vent frame. Raise window and check fit against side flap with door closed.

1. Top piping 2. Window glass 3. Vent frame

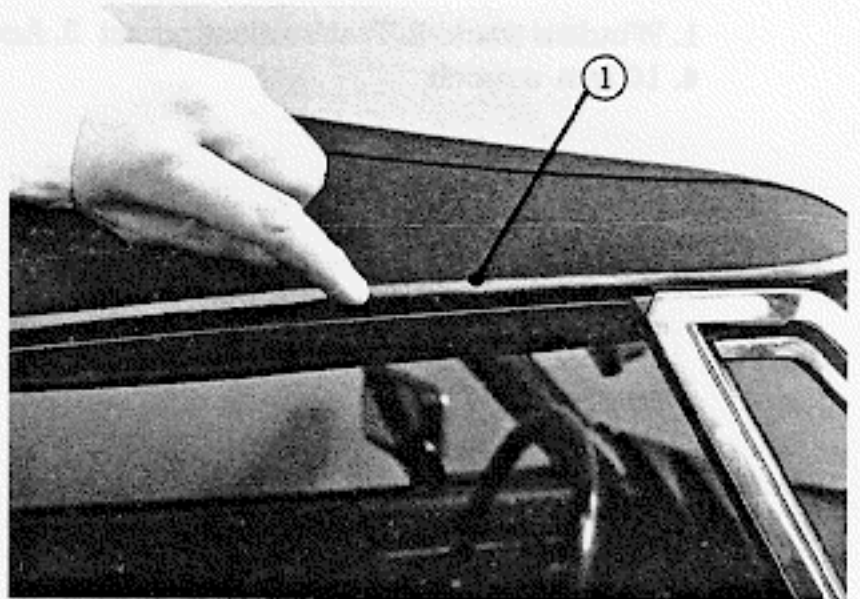
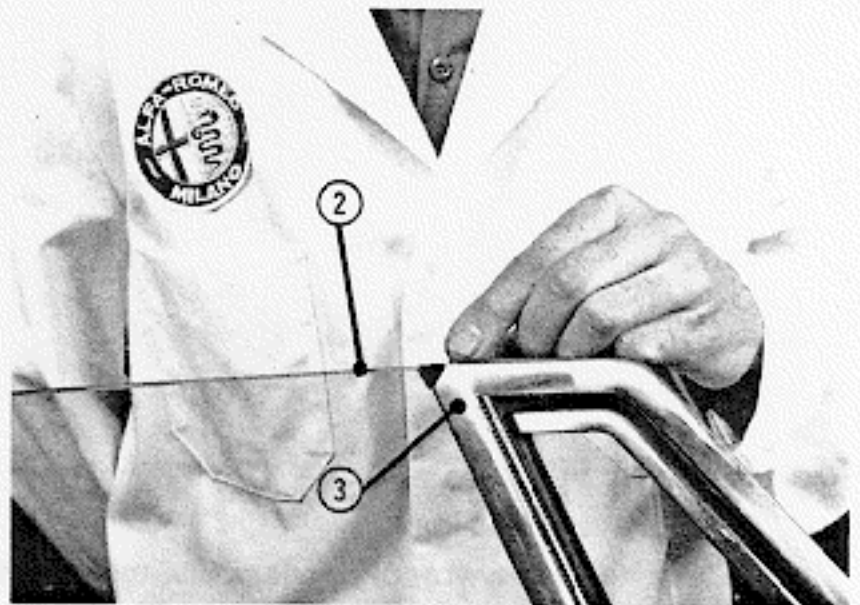

Window height correct.

Window/Side Flap Fit

If window height is correct but window does not press tightly against side flap when door is closed, adjust window laterally. To move window in or out, adjust angle of window track. To reach front window track adjusting nut, remove triangular access hole cover from lower front section of door.

1. Window 2. Window track 3. Track adjusting nut

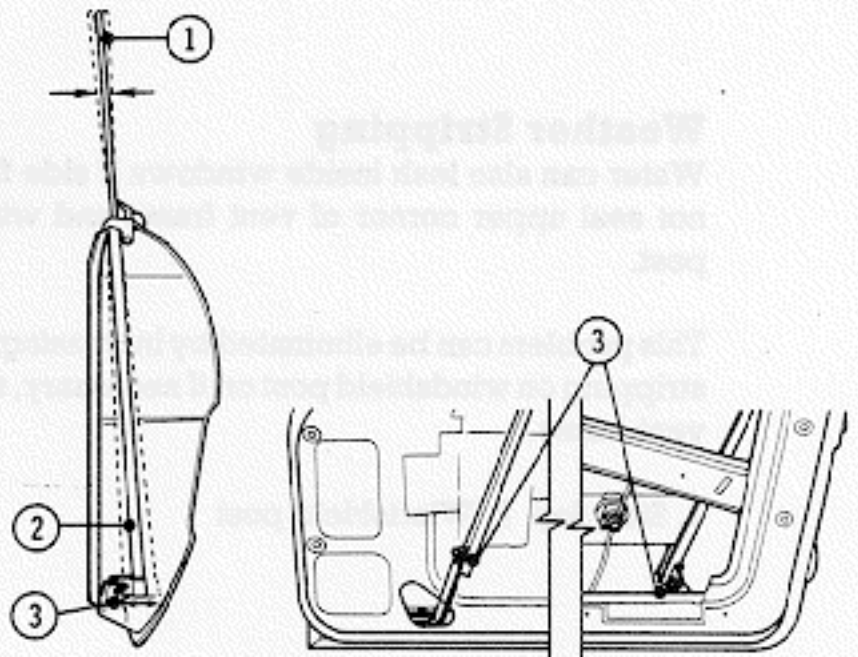

Lateral window adjustments.

TOP ADJUSTMENTS

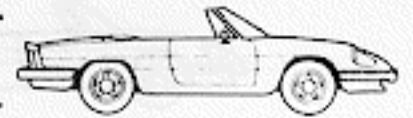

With a 10 mm wrench, loosen nuts, and adjust tracks in or out as necessary. Tighten nuts. Close door to check window/side flap fit.

1. Window track
2. Track adjusting nut
3. Access hole
4. 10 mm wrench

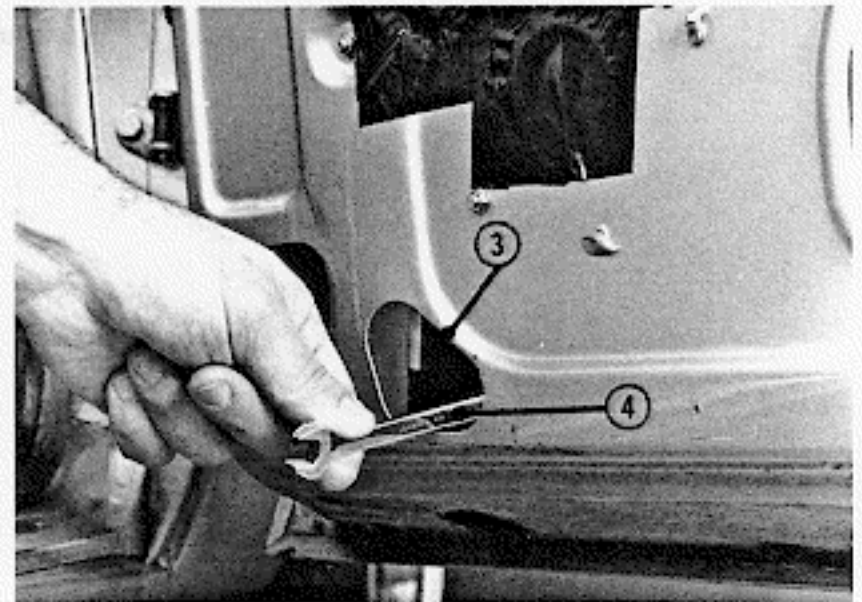
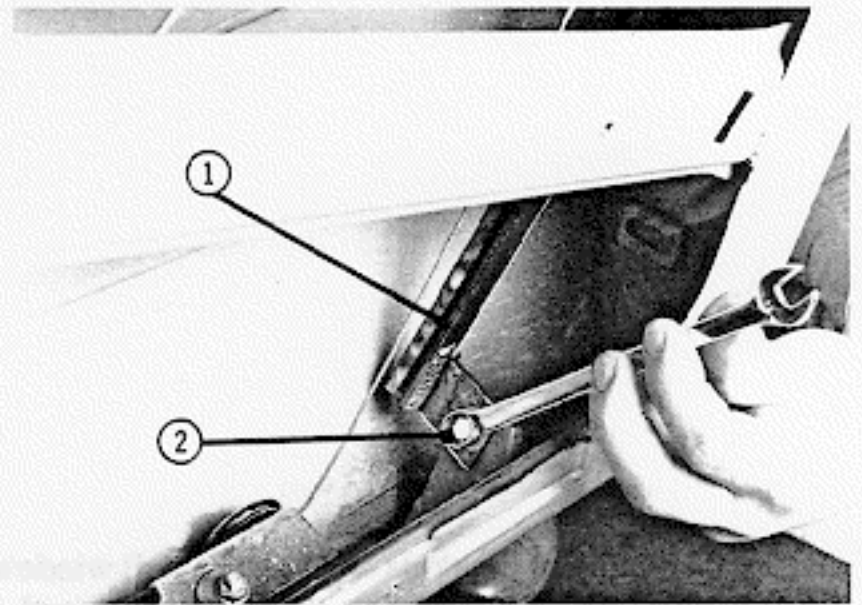

Adjusting window tracks.

Weather Stripping

Water can also leak inside windows if side flap does not seal upper corner of vent frame and windshield post.

This problem can be eliminated by increasing weather stripping on windshield post or, if necessary, adjusting vent frame.

1. Side flap
2. Windshield post

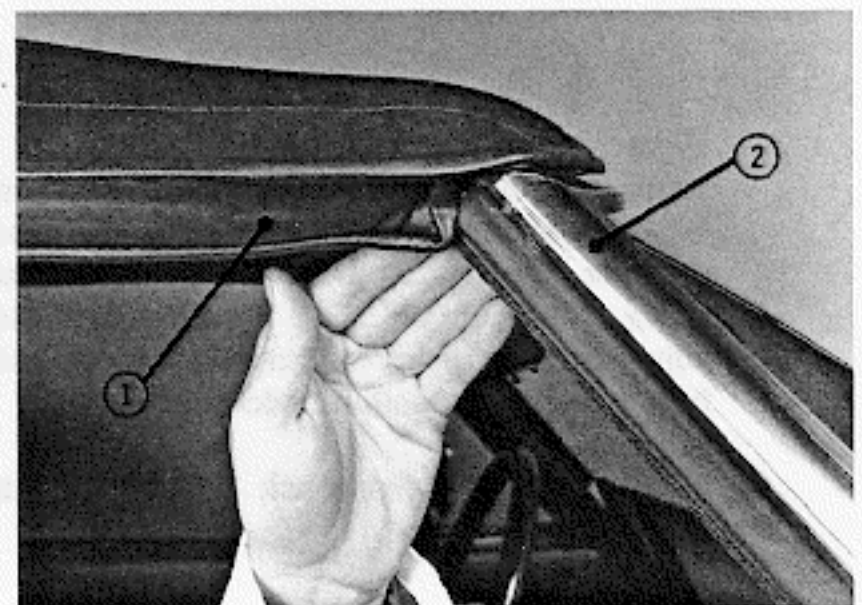

Proper side flap position.

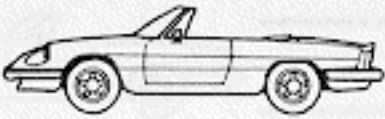

TOP ADJUSTMENTS

Sit inside car with roof latched and door closed. Visually inspect seal of vent frame and windshield post. If small amount of light is visible, increase weather stripping seal. If large gap exists, adjust vent frame.

1. Vent frame
2. Windshield post



Checking vent frame seal.

To increase sealing action of weather strip, use a Phillips screwdriver (2) to remove roof latch retainer and guide (1).

NOTE: Lower roof to perform this operation.

1. Latch retainer and guide
2. Phillips screwdriver

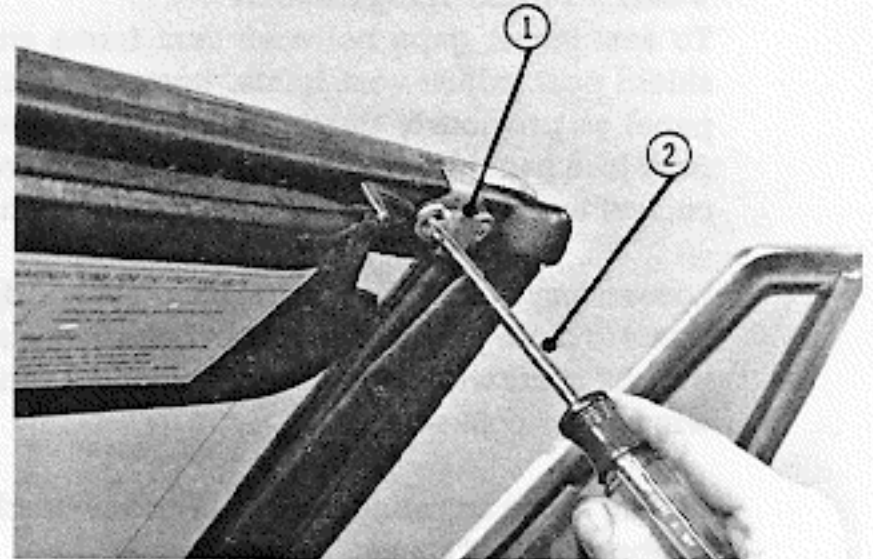

Removing retainer and guide.

Lift off corner molding, and fold back top of weather strip.

1. Corner molding



Removing corner molding.

TOP ADJUSTMENTS

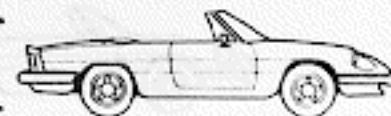

Place strip of sponge foam (1) approximately 1/4" square and 5" long into hollow of weather strip (2).

Apply adhesive to last 1/2" of sponge foam to hold in place.

Replace corner molding, roof latch retainer, and guide. Raise roof and latch. Sit in car with door closed. Reinspect vent frame/windshield post seal.

1. Sponge foam 2. Weather strip

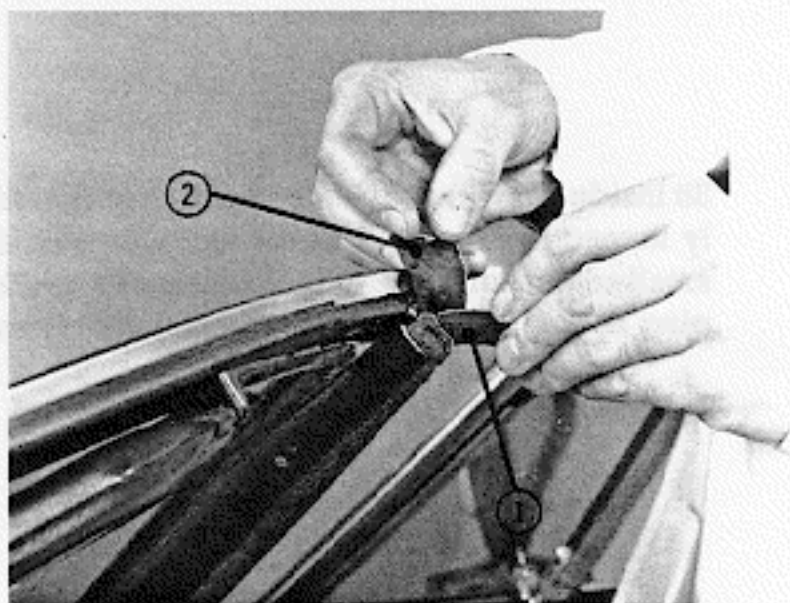

Placing sponge foam inside weather strip.

Vent Frame Alignment

To seal larger gaps between vent frame and windshield post, adjust vent frame. Remove interior door panel as previously described. Then remove upper door trim panel by removing two Phillips screws and conical washers. Pull panel up and out to remove.

Loosen four bolts shown in the illustration. Adjust vent frame to close gap, and retighten bolts. Raise and latch roof. Sit in car with door closed. Reinspect vent frame/windshield post seal.

1. Vent frame adjusting bolts 2. Window track adjusting bolt 3. Vent frame

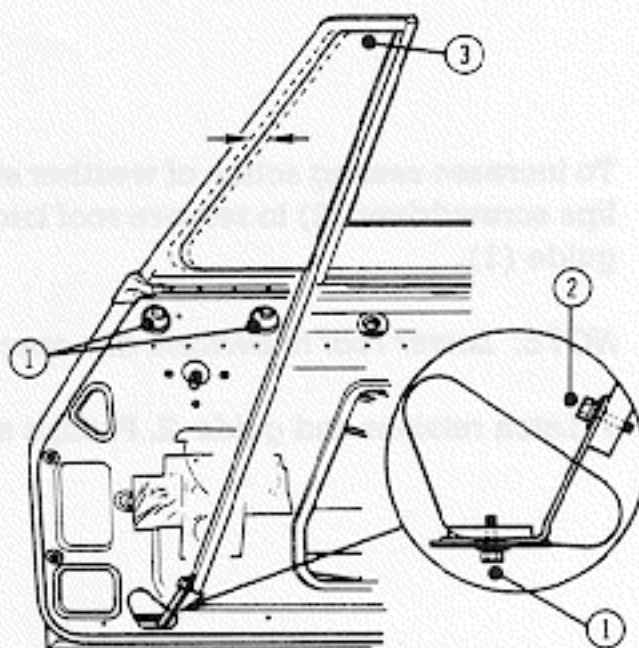

Vent frame adjustment.

Reassembling Door Hardware

When you have the correct window and vent frame alignment and seal, reinstall door hardware by reversing removal procedures.

- Reinstall plastic access hole covers and plastic rain guard, or replace with suitable materials.
- Attach upper trim panel to door with two screws and conical washers. Do not overtighten. Overtightening will wrinkle material.
- Lower rain skirt. Operate window to check for interference.
- Replace door panel. Be sure to align four clips with corresponding plastic inserts before installing five screws.
- Reinstall armrest. Start each of three screws before tightening any of them. Reinstall armrest trim pieces.
- Reinstall door handle and trim.



Installing armrest.



Top Piping/Windshield Bow Fit

Noise and vibrations in top may be caused by an improper fit of top piping to windshield bow. If front piping is not in continuous contact with windshield bow, air turbulence will occur, causing excessive noise and vibration.

1. Top piping 2. Windshield bow

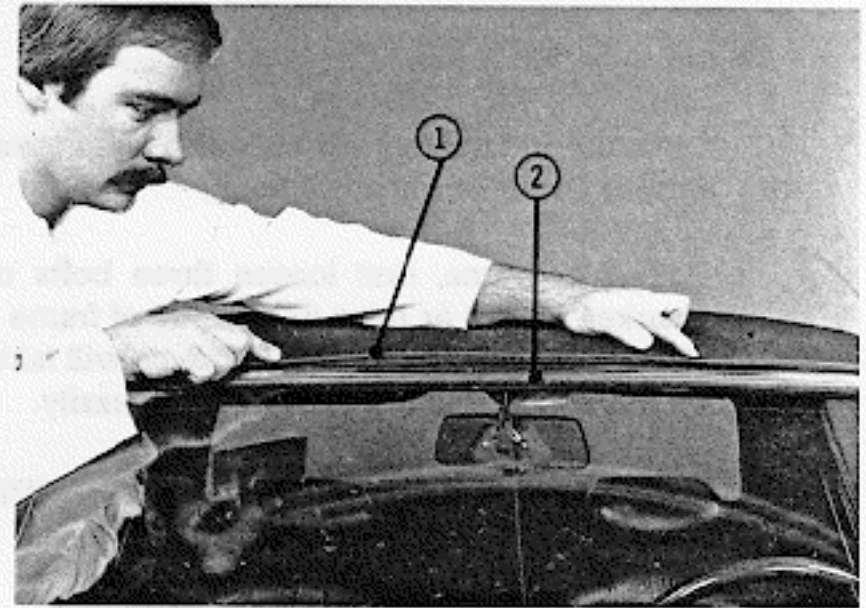

Top piping/windshield bow fit.

To correct this problem, lower top and remove front corner bolts, front gasket and gasket retainer, and corner rivets. Peel back top fabric from front of frame. Reposition and reglue top. Follow instructions in TOP REMOVAL and TOP INSTALLATION sections of this book.

If top cannot be pulled forward enough to reposition front piping properly it may be necessary to replace top with new one. Follow instructions contained in TOP REMOVAL and TOP INSTALLATION sections.

1. Top piping 2. Windshield bow

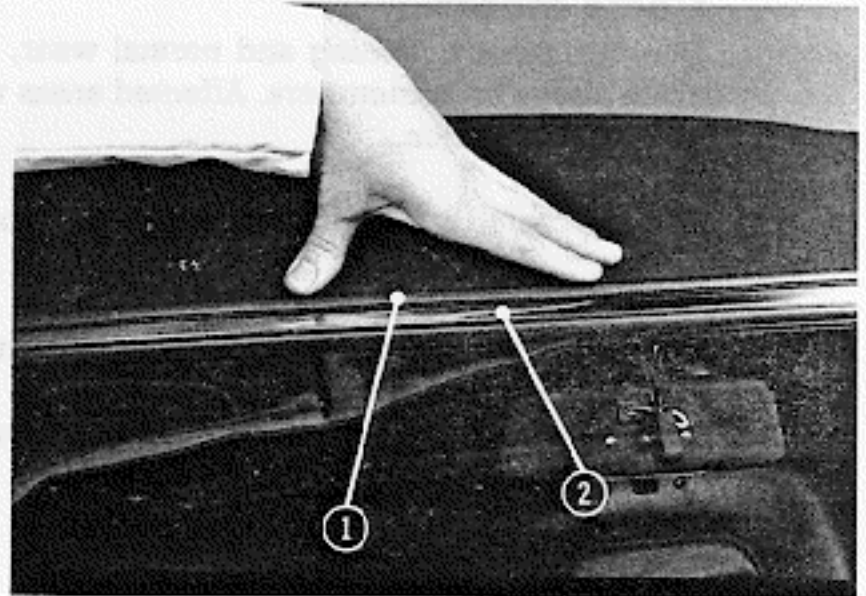

Properly seated front piping.

Latching Top

A stopblock (1) on each side of top frame bears against frame linkage arm (2) to give rigidity to frame.

If there is difficulty in latching one or both sides of top, file stopblock or blocks until top can be latched without excessive effort.

NOTE: Touch up file marks with black enamel paint.

1. Stopblock 2. Frame linkage arm

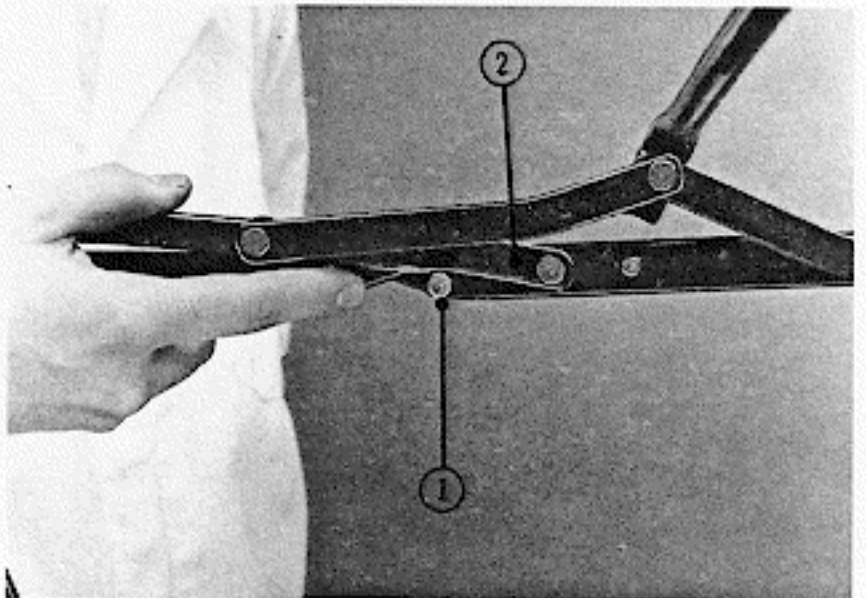

Stopblock.

TOP ADJUSTMENTS

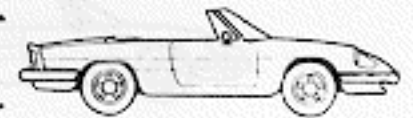

Difficulty in latching top may also be a result of improper frame height adjustment.

To adjust frame, first loosen three bolts on frame bracket. Lower or raise either side of frame until desired fit is achieved. Lowering frame will take tension off top and permit top to close more easily.

1. Frame bracket
2. Bolts
3. Frame side support

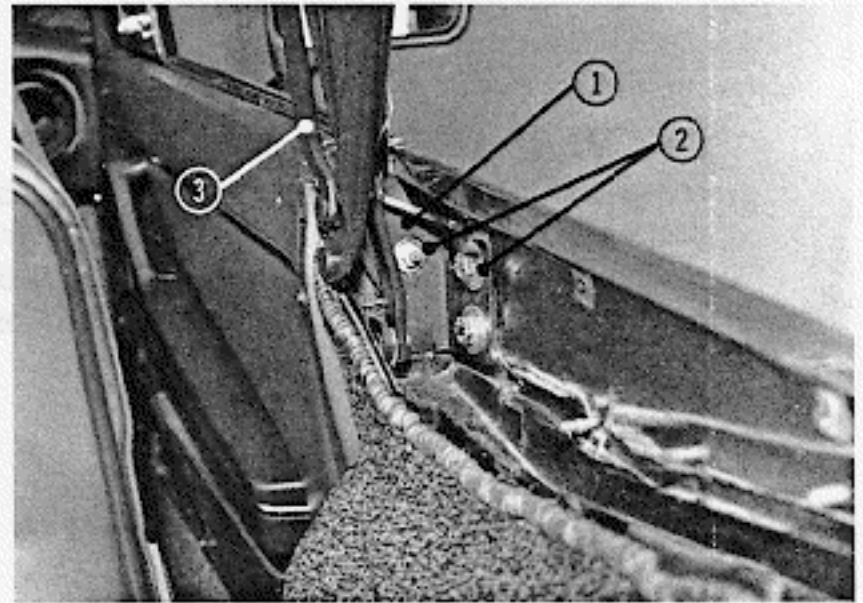

Frame bracket.

Chafe Marks

Due to improper folding and normal wear, top may chafe above crossmembers. Affected areas will have white discoloration.

Refinish chafed areas with convertible top fabric spray or dye.

Educate owner in proper way to fold vinyl window and top. Periodic brushing of fabric top using a bristle brush will prolong the new condition and reduce wear.

1. Chafe marks

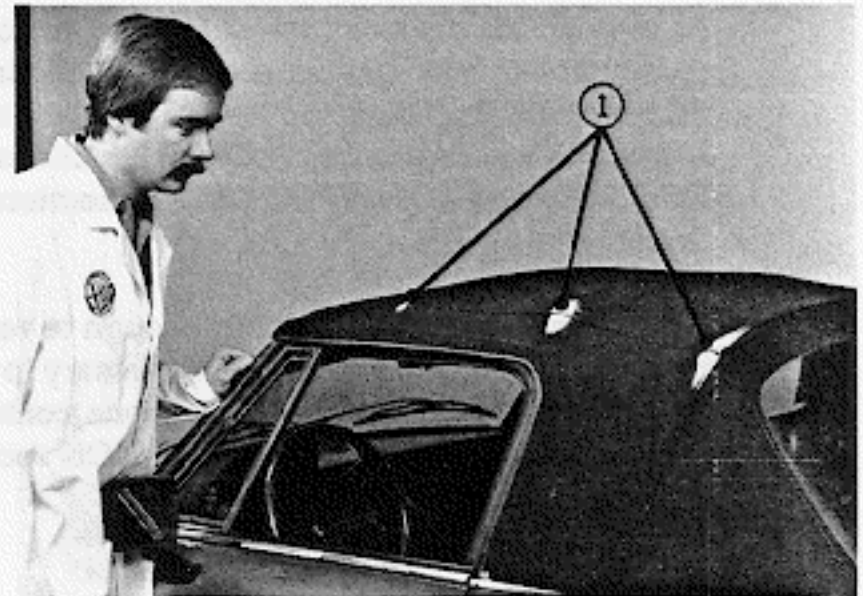

Chafe marks.

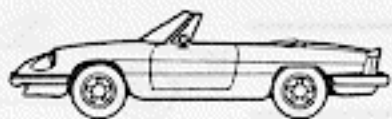

Removing Edge Guide

Begin removal of top with top raised and latched.

Use a Phillips screwdriver to remove chrome edge guide (1) located above doorjamb on both sides of top.

1. Chrome edge guide

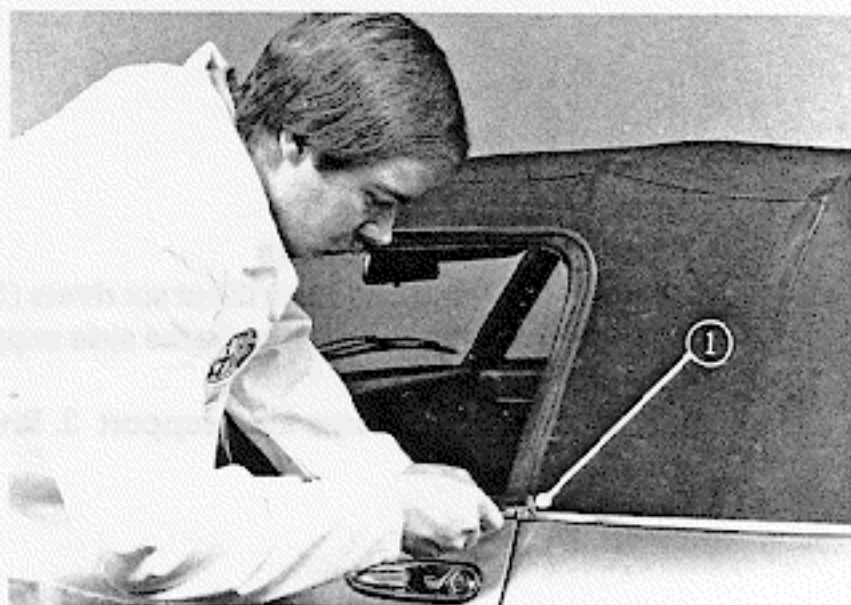

Removing chrome edge guide.

Removing Retainer Strips

Inside the car, use a Phillips screwdriver to remove eight carpet retaining screws (1) holding carpet to rear water channel.

Fold down carpet and carefully lift up vinyl trim glued to front of water channel.

1. Carpet retaining screws

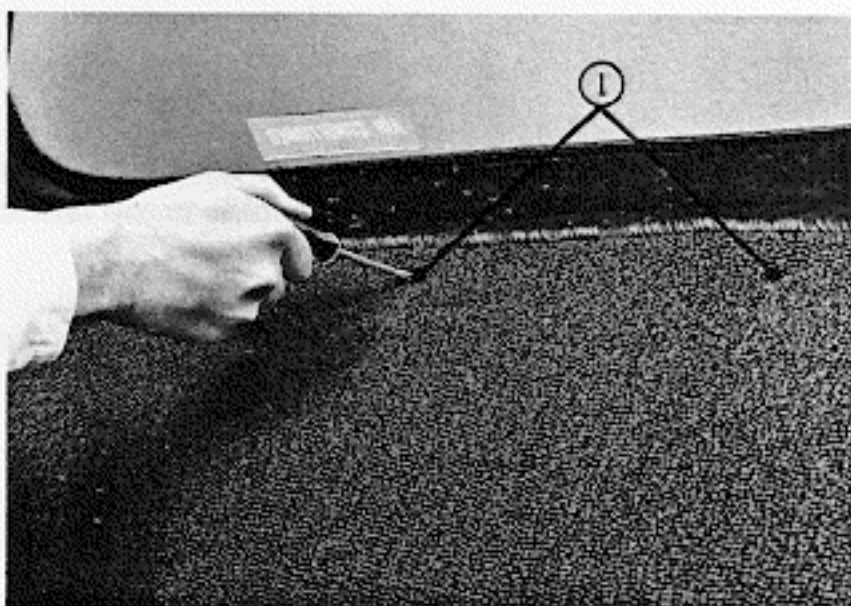

Removing carpet retaining screws.

Use an 8 mm wrench or nut driver (3) to remove twenty-two nuts and washers (2) used to fasten side and rear retainer strips in water channel.

Remove retainer strips (4) and vinyl trim (1) from studs.

NOTE: Avoid getting glue on interior finish and upholstery.

1. Vinyl trim
2. 8mm nut
3. 8mm nut driver
4. Retainer strip

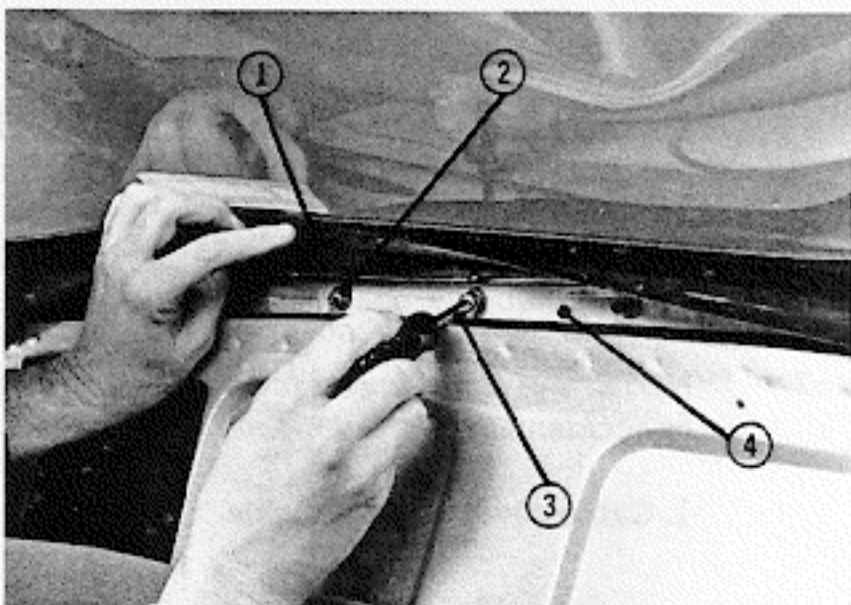

Removing retainer strips.

TOP REMOVAL

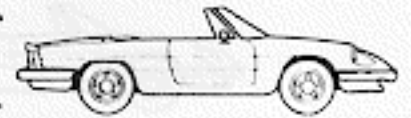

Removing Top from Frame Side Supports

Using an 1/8" drill bit (1), drill out six rivets (3)—three on each side—holding top to frame side supports (2).

1. 1/8" drill bit 2. Frame side support 3. Rivet

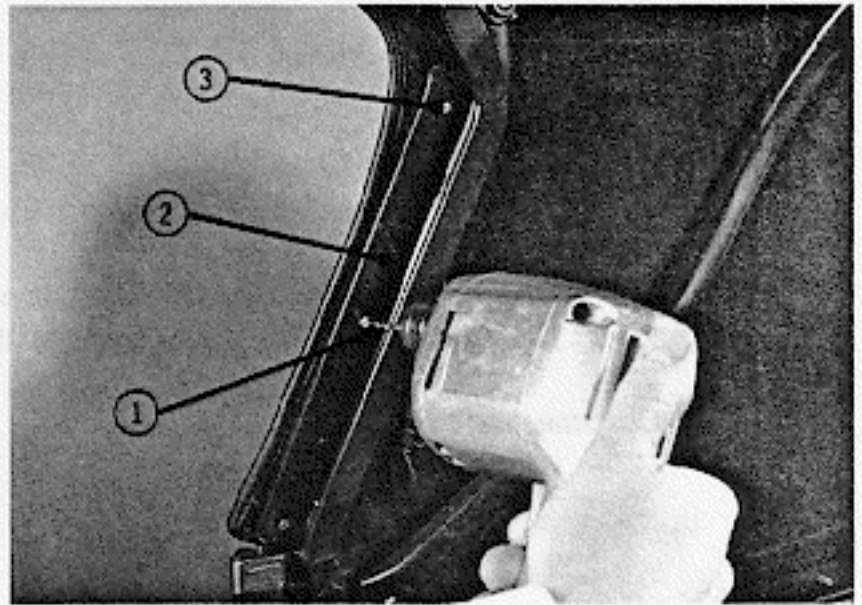

Removing rivets from support.

After removing rivets, fold back side flaps, remove rivet backing plates from folds in top fabric, and pull glued top fabric away from frame.

Redrill rivet holes in plates to remove any remaining rivet material.

1. Rivet backing plate 2. Fabric flap

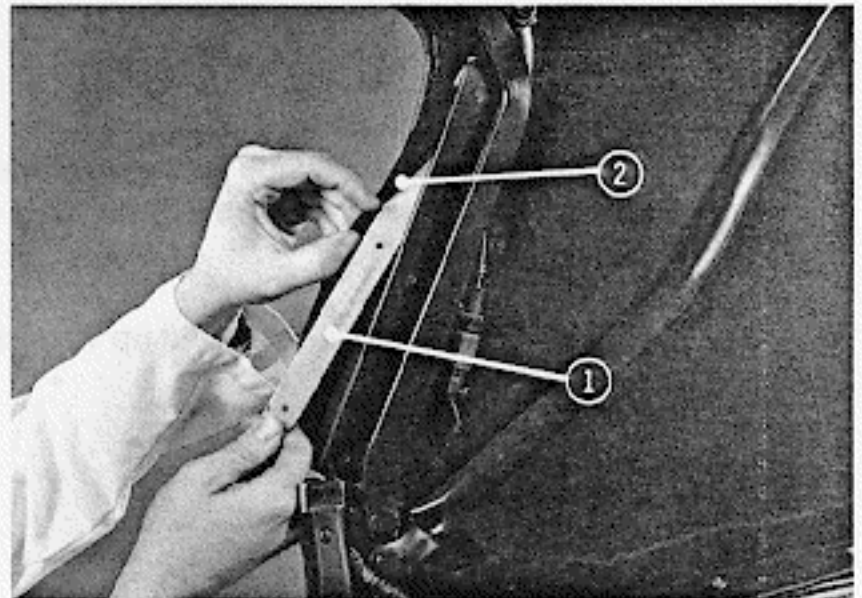

Removing rivet backing plate.

Removing Cables from Turnbuckles

Release roof latches to take tension off cables.

On both frame supports, remove vinyl cable covers (1) located below turnbuckles (2).

NOTE: Put cable covers in safe place so as not to lose or accidentally discard them.

1. Cable cover 2. Turnbuckle

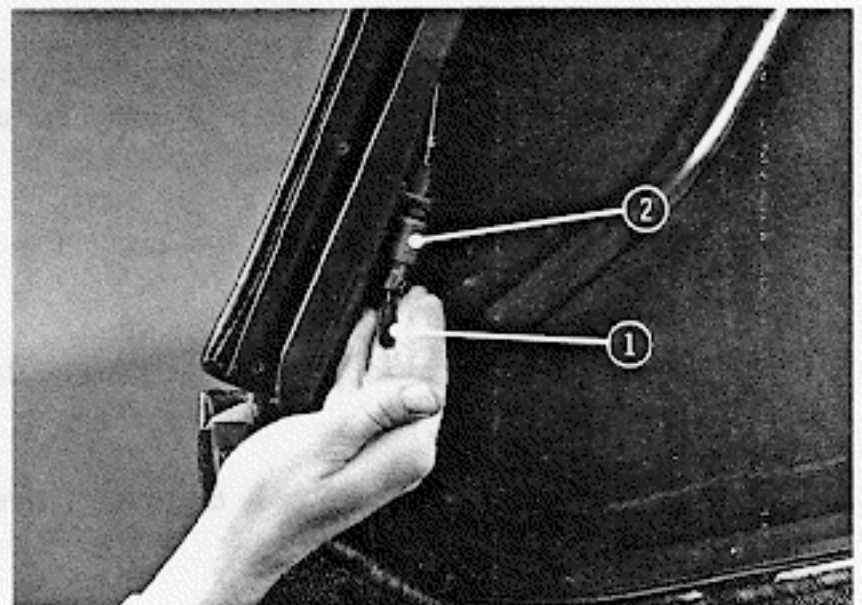

Removing cable covers.

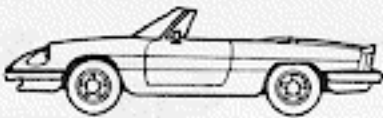

TOP REMOVAL

Use a 7 mm wrench (1) to remove locknuts (2) below turnbuckles.

1. 7mm wrench 2. Locknut

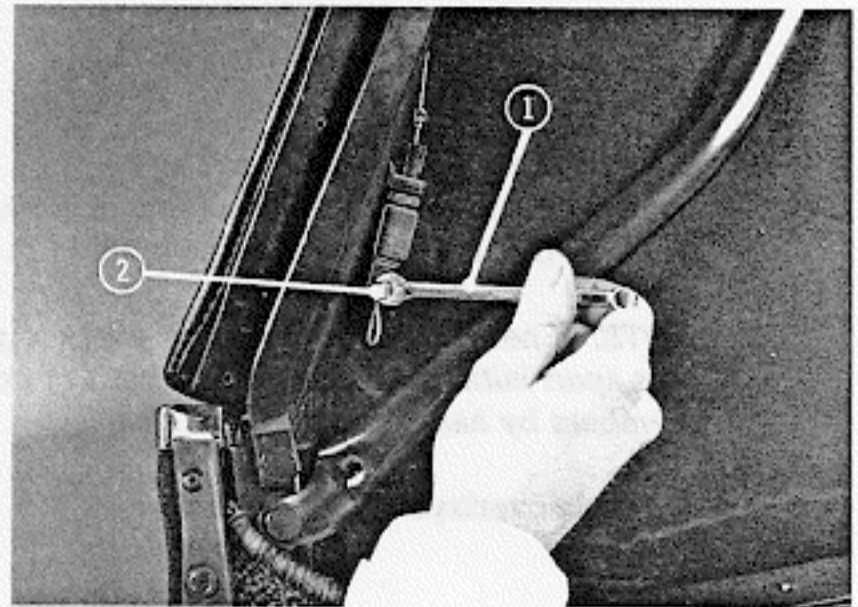

Removing locknut.

Remove locknuts (1) and tensioner springs (2) from turnbuckles.

NOTE: Be sure to put these parts in a safe place where they will not be lost or discarded.

1. Locknut 2. Tensioner spring

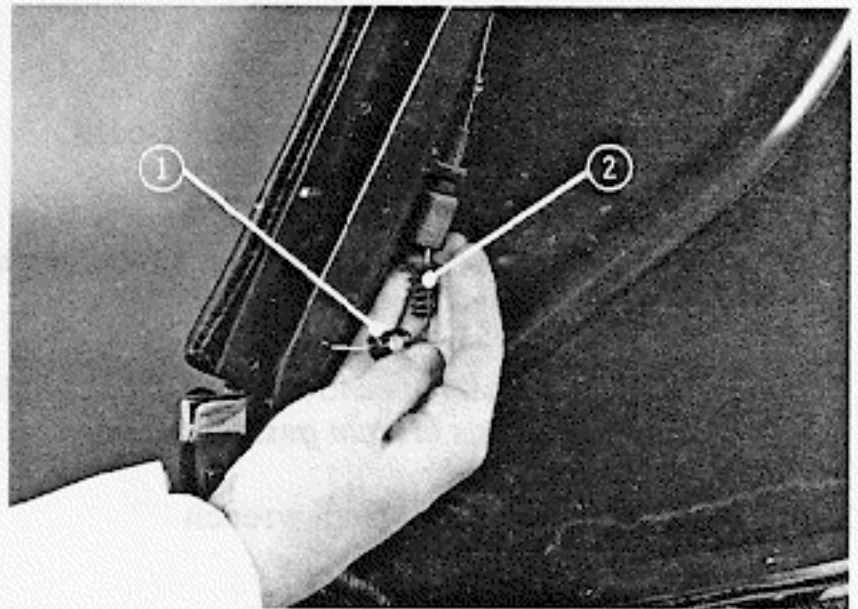

Removing locknut and spring.

Straighten cables and pull through top of turnbuckles.

Use a 7 mm wrench (2) to loosen upper cable guides (1).

Remove guides from cables.

NOTE: Place cable guides in safe place with other components that must not be lost or discarded.

1. Upper cable guide 2. 7mm wrench

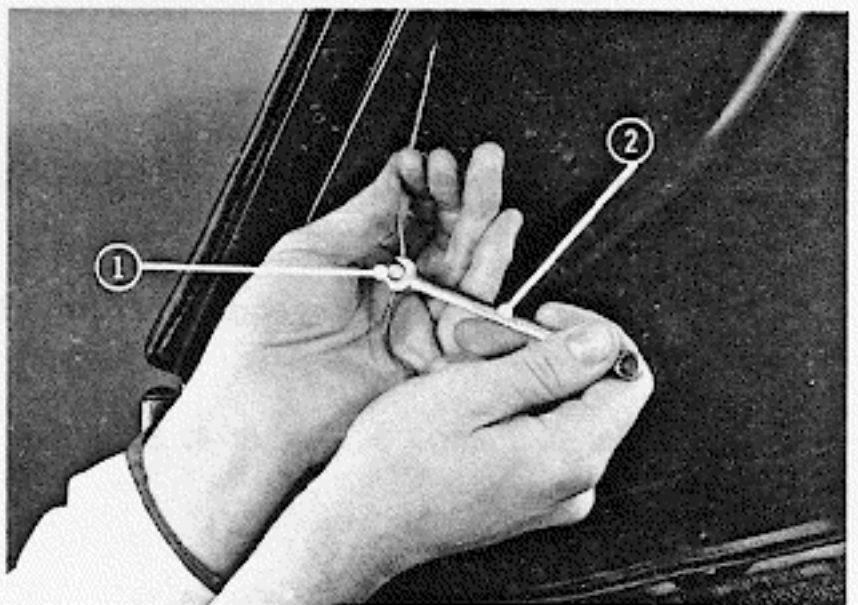

Removing upper cable guide.

TOP REMOVAL

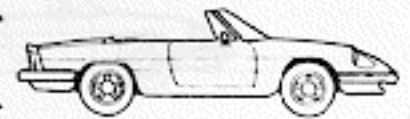

Removing Fabric Overlays

Latch roof and reach above to remove cloth overlays (1) from the three frame crossmembers (2).

NOTE: If necessary, carefully use pliers to pull overlays apart initially, but then peel overlays from crossmembers by hand.

1. Fabric overlays 2. Crossmember

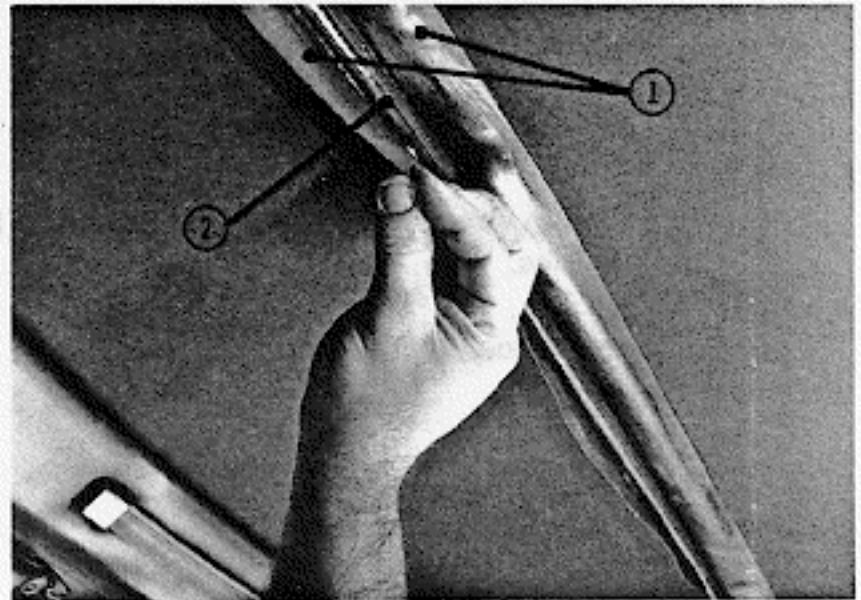

Removing fabric overlays.

Removing Front Corner Bolts

Unlatch roof and fold back.

Use a 7 mm wrench (2) to remove retaining nuts (1) in front corners of roof.

NOTE: Special nuts and flathead T-bolts hold corners of top and ends of front gasket to frame.

1. Retaining nut 2. 7 mm wrench

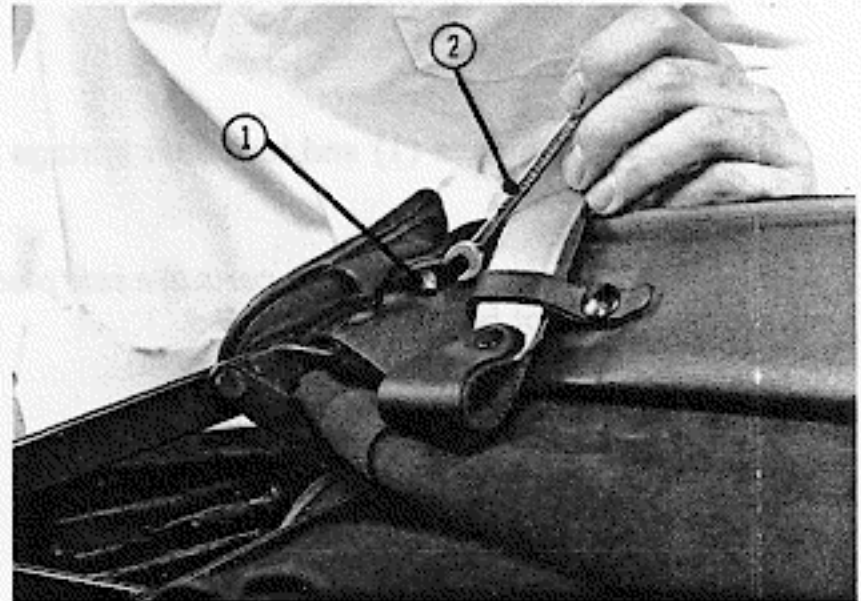

Removing retaining nuts.

After removing corner nuts, remove special T-bolts from pockets in front corners of top.

NOTE: Be sure not to lose or discard flathead bolts and nuts.

1. Nut 2. Flange 3. Gasket 4. Side flap 5. T-bolt 6. Pocket

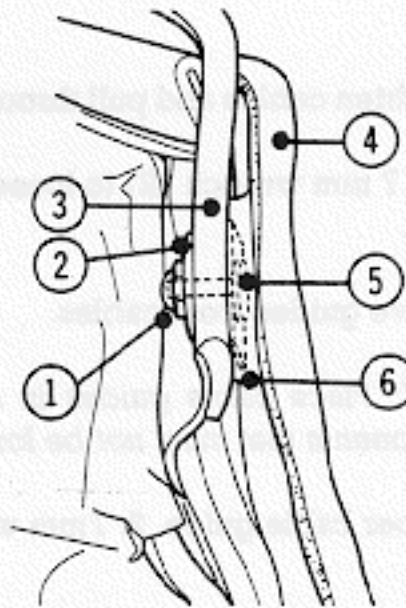

Front corner bolted to frame.

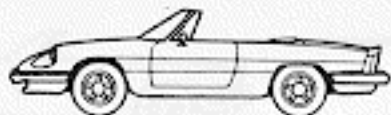

Removing Top from Front of Frame

Remove front rubber gasket (1) by pulling it out of metal retainer.

1. Front rubber gasket



Removing rubber gasket.

Using an 1/8" drill bit, drill out six rivets holding front gasket retainer to frame.

Drill out the two rivets holding top side flaps to front corners of frame.

NOTE: When drilling is complete, clean up all metal shavings from both interior and exterior of vehicle.

1. 1/8" drill bit
2. Rivet
3. Gasket retainer

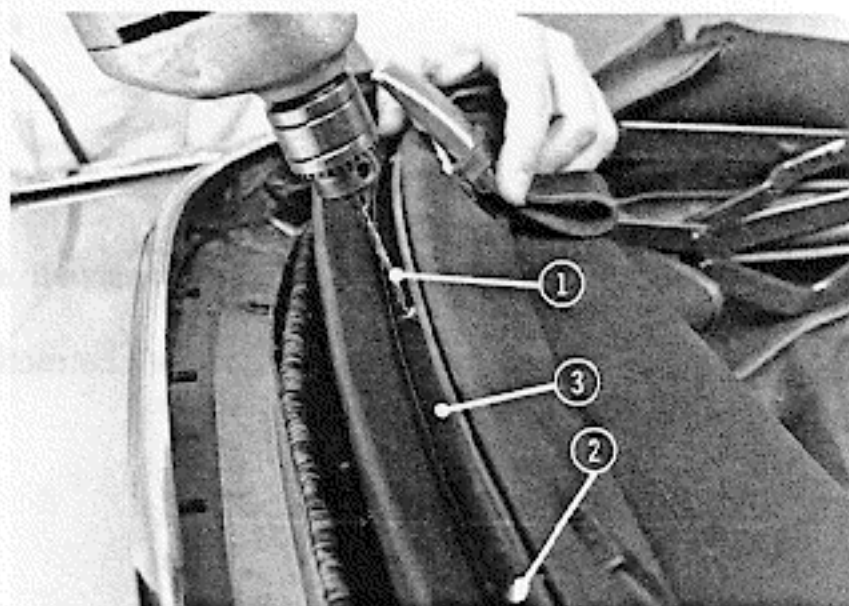

Removing rivets from retainer.

Peel top fabric (1) from front of frame (2).

1. Top fabric
2. Top frame

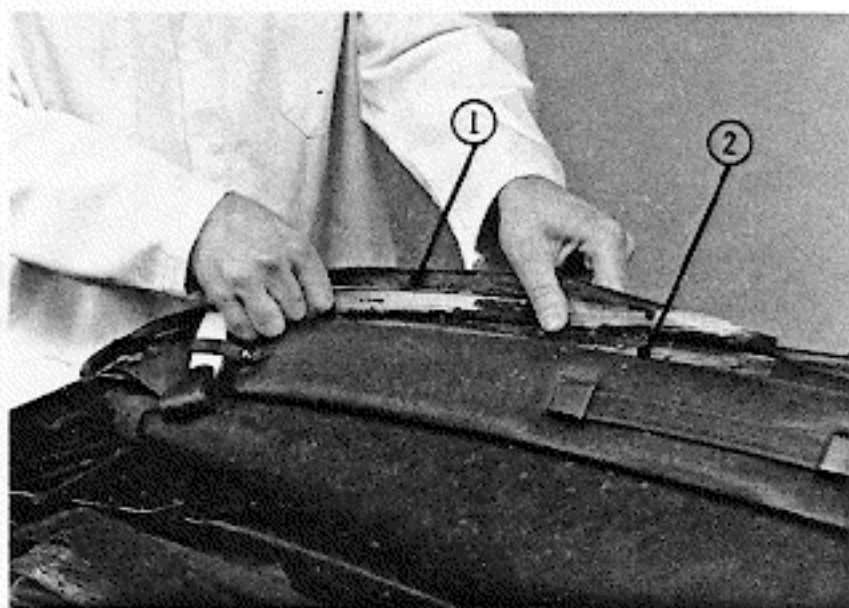

Peeling fabric from frame.

TOP REMOVAL

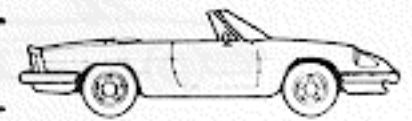

Removing Cables

Pull cables out of top sleeve. Top may now be removed from car.

NOTE: Do not kink cables when removing from top.

1. Cable 2. Top sleeve

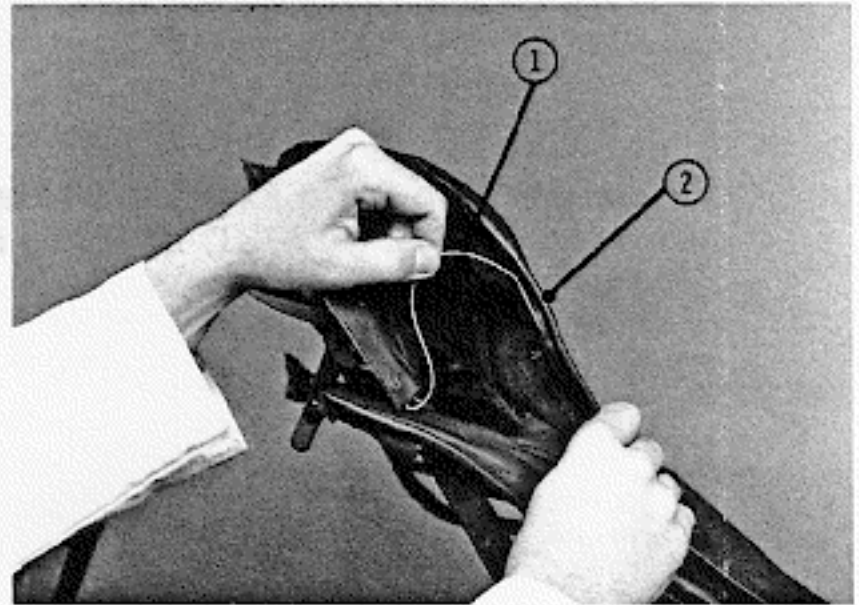

Removing cables from top.

Cleanup and Inspection

Use suitable solvent to clean old adhesive from frame.

Make sure all rivet holes are free of obstructions. Re-drill with 1/8" drill bit, if necessary.

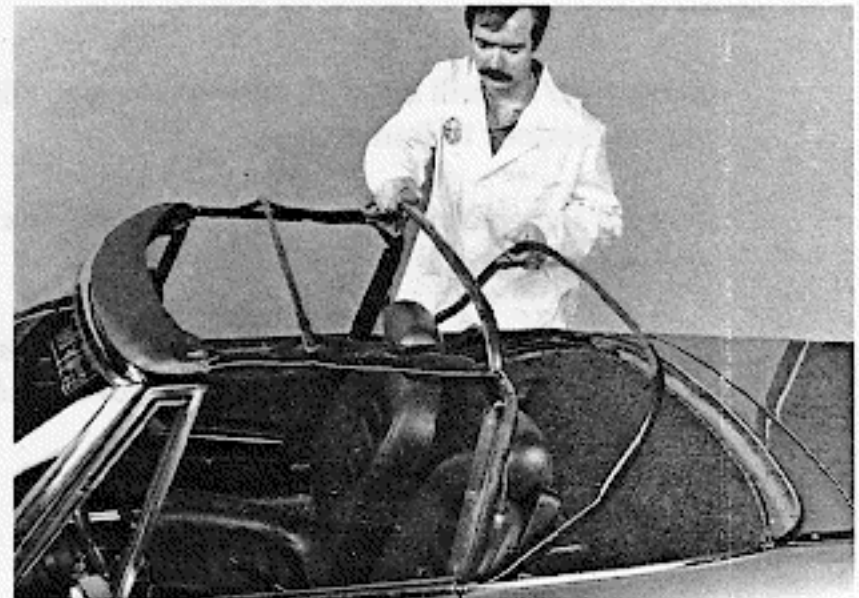

Cleaning frame with solvent.

Vacuum dirt and debris from water channel (1). Make sure four drain holes (2) and hoses are not clogged.

1. Water channel 2. Drain hole

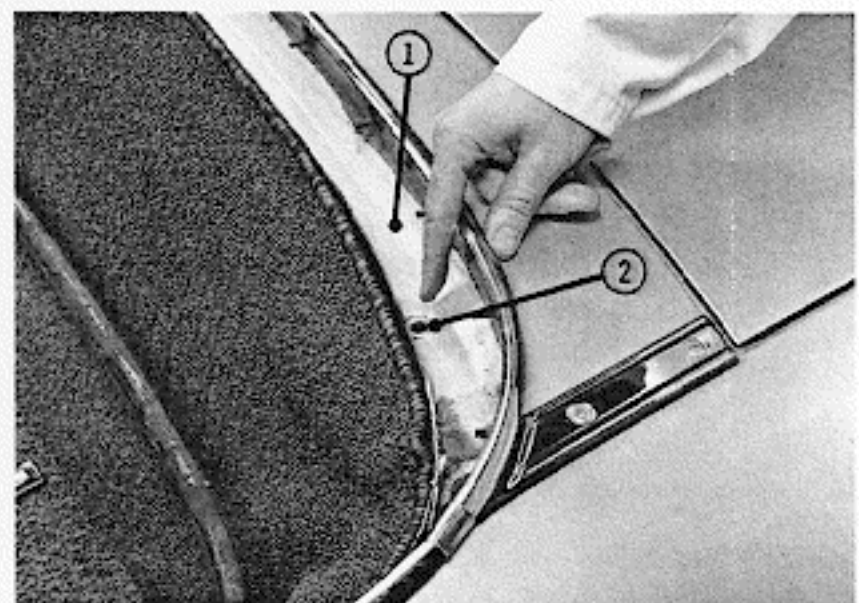

Checking drain holes for obstructions.



TOP INSTALLATION

When replacing convertible tops, current side flap design (1) is preferred over two former designs (2) and (3).

Leave protective plastic and fabric on rear window until installation is complete.

Protect car with fender covers when applying adhesives.

1. Current side flap design 2.-3. Former side flap designs

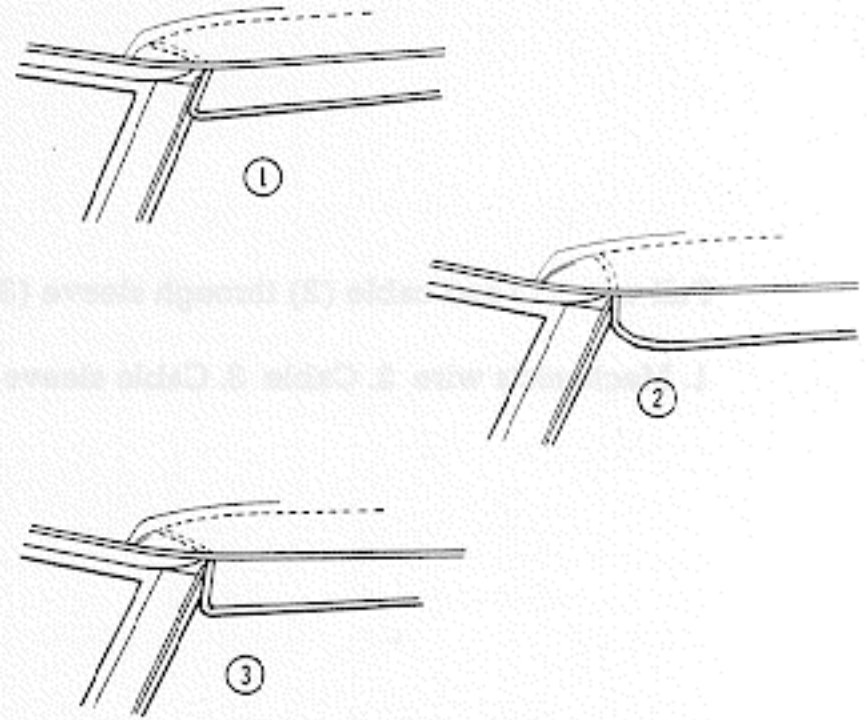

Side flap designs.

Installing Cables

Raise frame and lay new top over it.

Bend one end of a piece of mechanic's wire (1) into shape of hook.

Slip hook into rear end of cable sleeve (2).

1. Mechanic's wire 2. Cable sleeve

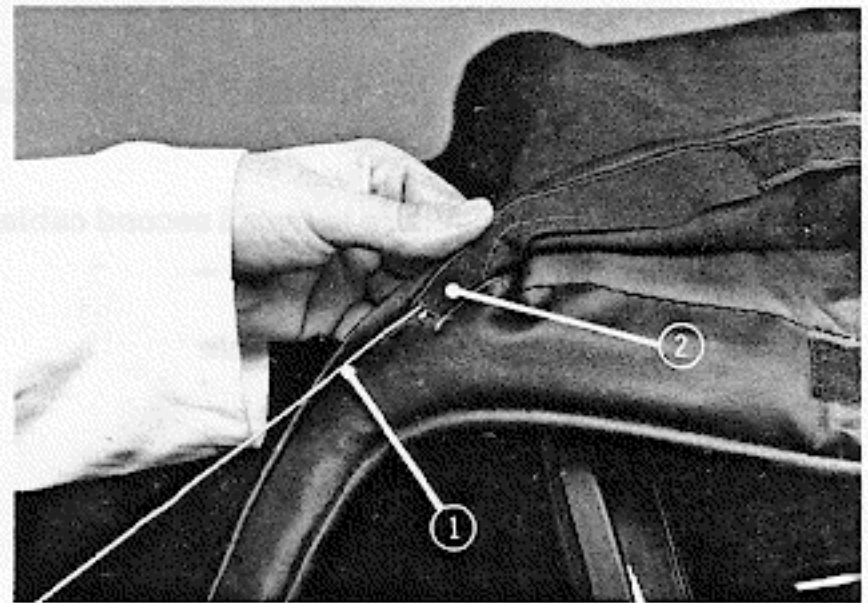

Inserting wire into sleeve.

Carefully push wire (1) through sleeve (3) until it comes out through front opening.

Loop end of cable (2) and secure with tape.

Hook mechanic's wire onto loop of cable.

1. Mechanic's wire 2. Cable 3. Cable sleeve

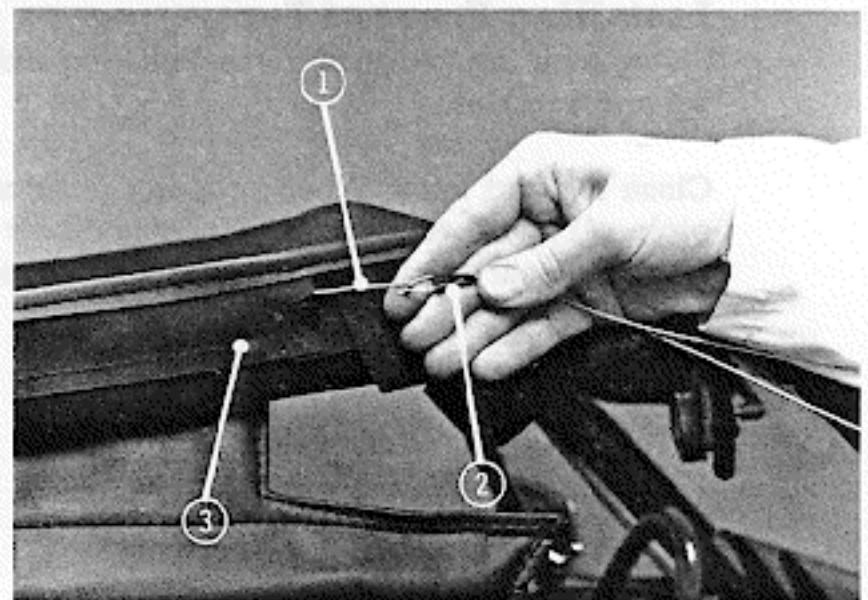

Wire hooked onto cable.

TOP INSTALLATION

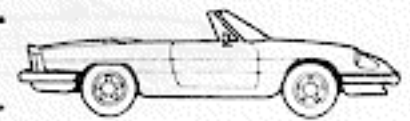

Pull wire (1) and cable (2) through sleeve (3).

1. Mechanic's wire
2. Cable
3. Cable sleeve

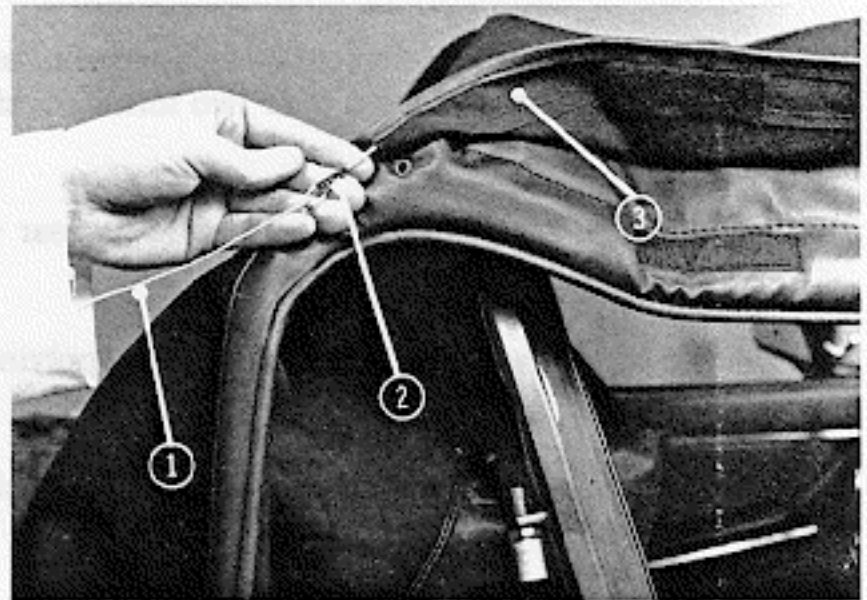

Cable pulled through sleeve.

Straighten cable (2) and feed through upright side support of frame.

Repeat this procedure to install second cable in other side of top.

1. Upright side support
2. Cable

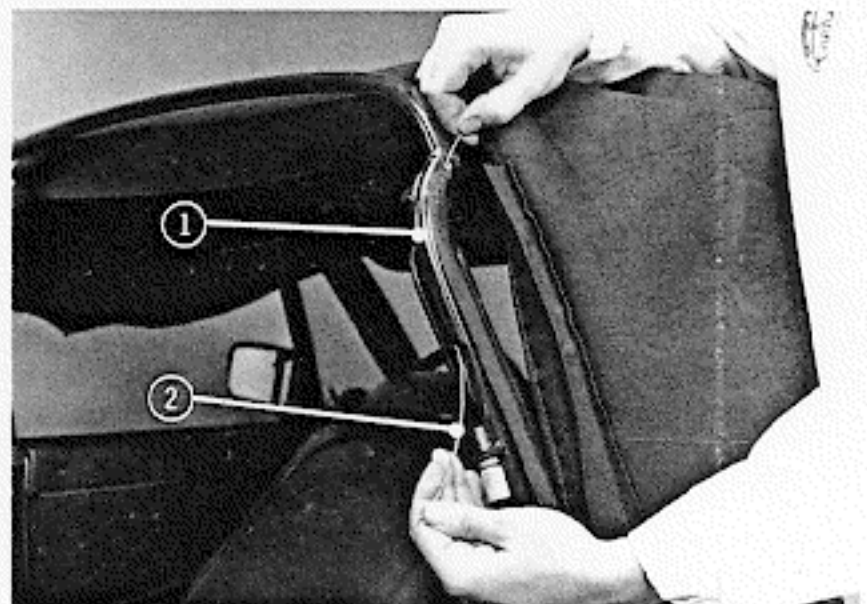

Feeding cable through side support.

Installing Front of Top

Fit top over front edge of frame. Pull tight and smooth out any wrinkles.

Close top and latch. When properly positioned, top piping (1) will press against windshield bow (2), and side flaps will overlap windshield post gasket.

Reposition top until desired fit is achieved.

1. Top piping
2. Windshield bow

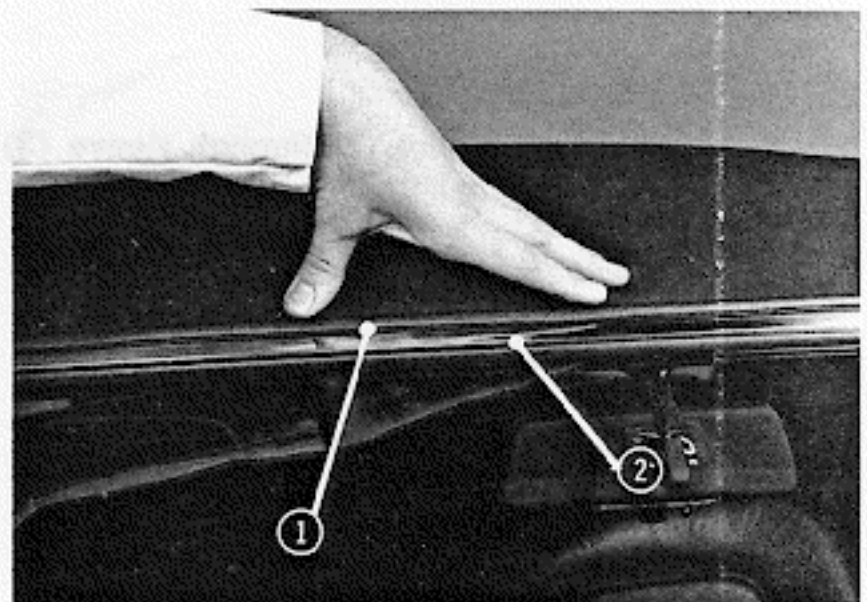

Proper position of piping against window bow.

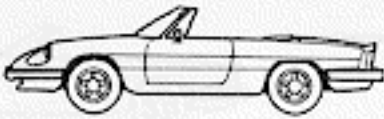

TOP INSTALLATION

When satisfied with fit, carefully fold back top with frame.

Lift top fabric from front edge of frame, and with a 1" bristle brush (1), carefully apply a coat of adhesive (neoprene-base contact cement) (2) to front edge of frame (3).

NOTE: Do not apply adhesive too heavily. Excessive adhesive will be forced out onto interior trim where it will stain.

1. 1" bristle brush 2. Adhesive 3. Frame

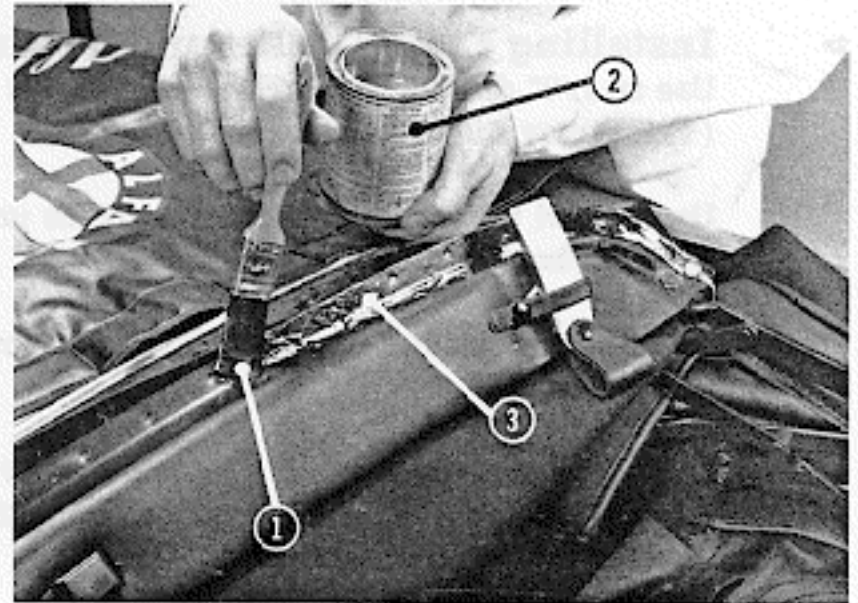

Applying adhesive to front edge of frame.

Pull edge of top forward while pressing fabric flap down onto front edge of frame. Top piping must be positioned on frame's inside edge.

Raise and latch top and check fit. If top piping is not in continuous contact with windshield bow, lay top back, peel up glued fabric, and pull fabric forward while pushing it down.

1. Fabric flap 2. Frame 3. Top piping 4. Top fabric

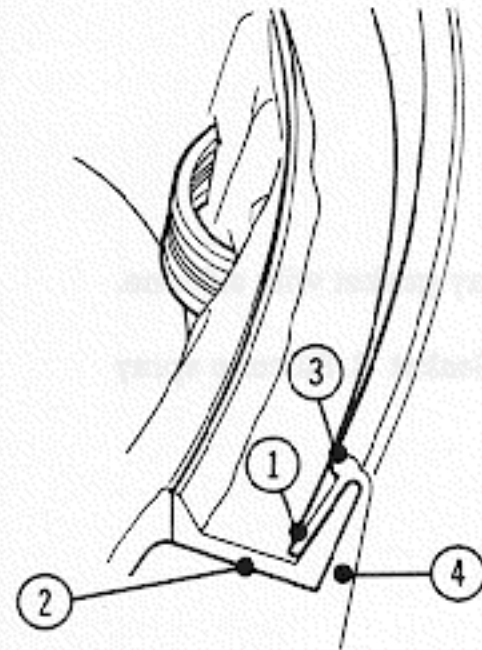

Proper position of top piping.

When satisfied with fit, fold back top with frame, and be sure there are no bubbles or creases in fabric where it is glued to frame.

Allow adhesive to set for at least 30 minutes before continuing with installation. (See instructions on adhesive label for correct drying times.)



Applying top to frame front edge.

TOP INSTALLATION

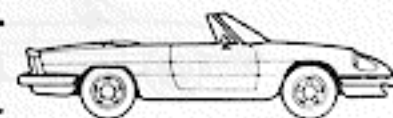

Installing Front Gasket and Retainer

Use an 1/8" drill bit to redrill holes in gasket retainer (1) that may still contain old rivets.

Use an awl to locate the eight rivet holes under top fabric in front ridge of frame.

Align gasket retainer over each hole and secure with pop rivets.

NOTE: Be sure rivet heads are fully seated against retainer. Raised rivet heads will interfere with gasket installation and possibly damage gasket.

1. Gasket retainer
2. Pop rivet gun

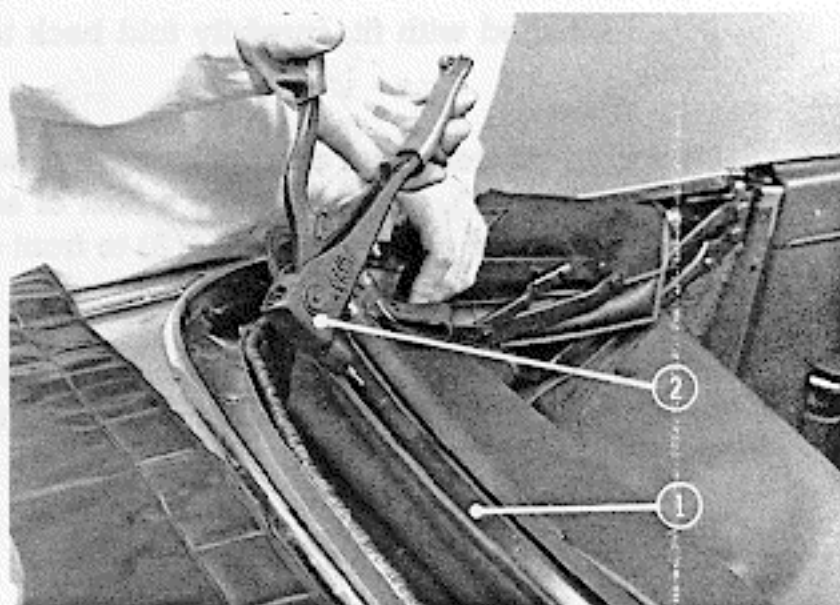

Installing gasket retainer.

Spray gasket with silicone.

1. Gasket
2. Silicone spray

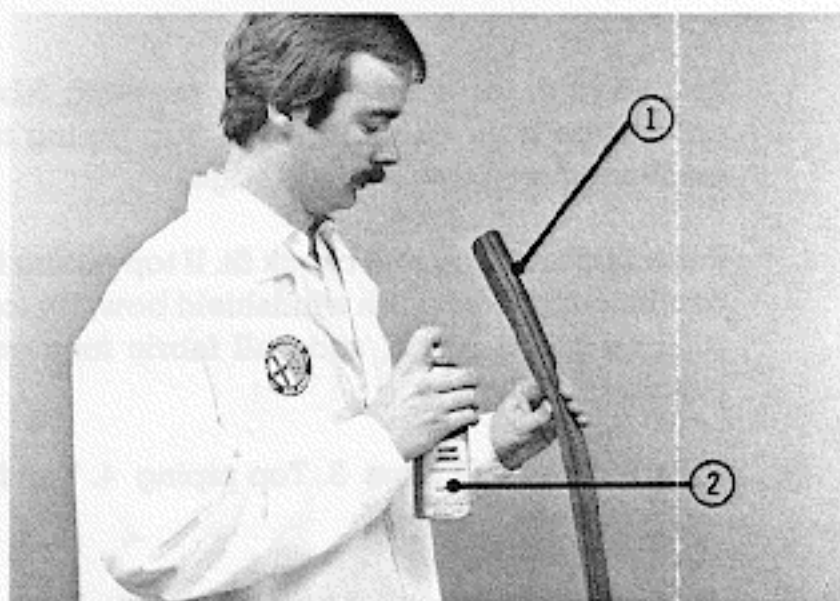

Spraying gasket with silicone.

Slide gasket into gasket retainer track. Install gasket with rolled lip toward front of frame.

Press down as you feed gasket (1) into retainer (4). Leave approximately 5" of gasket on both sides of top.

1. Gasket
2. Rolled lip
3. Top
4. Retainer
5. Frame

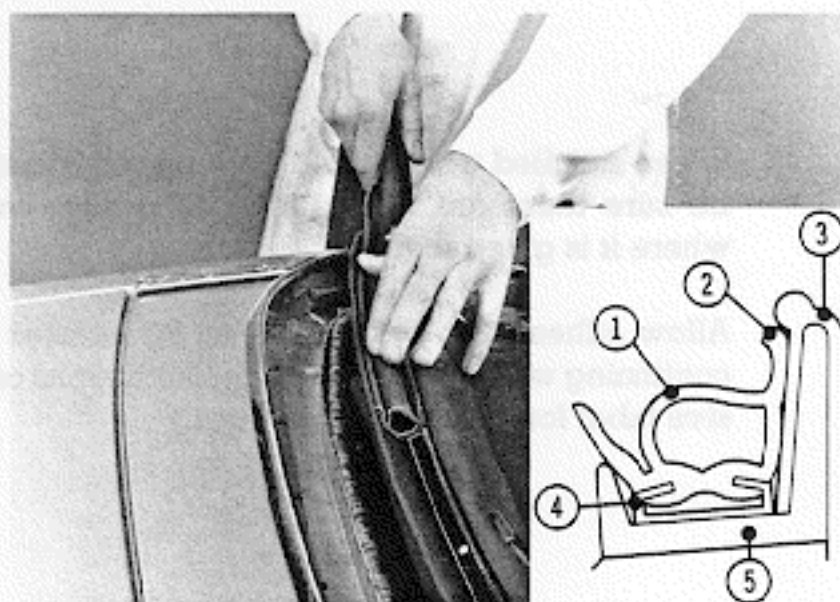

Sliding gasket into retainer.

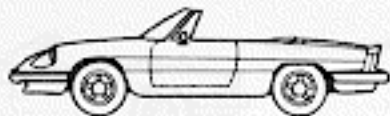

TOP INSTALLATION

Mark gasket ends with chalk as shown in illustration.
Mark line (1) 1-1/2" from end of gasket retainer (4).
Mark line (2) from line (1) to end of gasket.

1. Cutline 2. Cutline 3. Gasket 4. Retainer

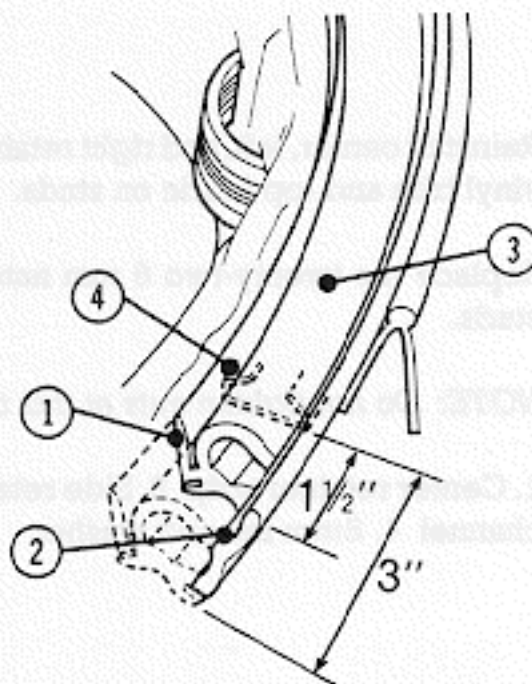

L-shaped cutout on gasket end.

Use scissors to make L-shaped cutouts along chalk lines on both ends of gasket.

Fill hollow ends of gasket with 1" to 2" of sponge foam.

1. Scissors 2. Gasket 3. Outline of cut

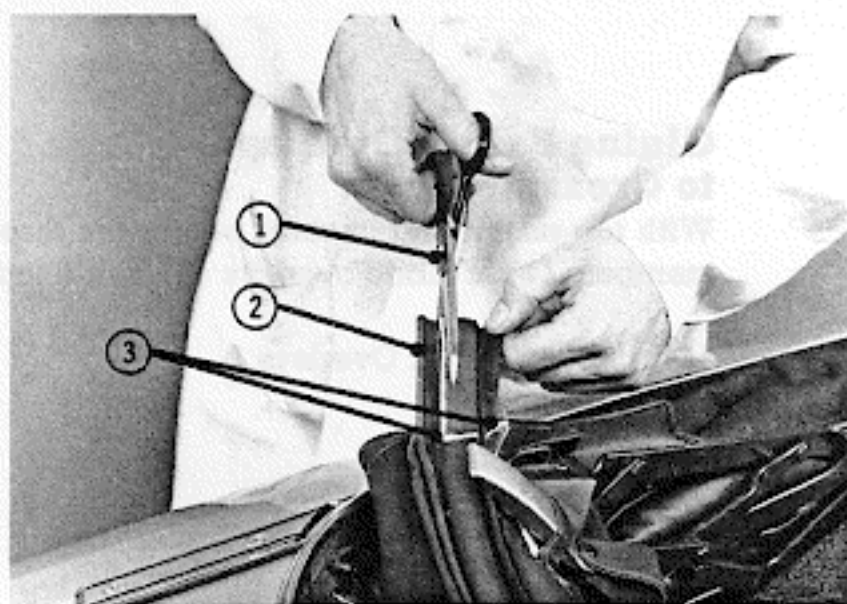

Cutting ends of gasket.

Attaching Top to Rear Water Channel

Fit holes in rear of top fabric over studs above water channel.

Reinstall three vinyl trim pieces over studs. Position side without adhesive against top fabric.

1. Vinyl trim 2. Top fabric 3. Water channel

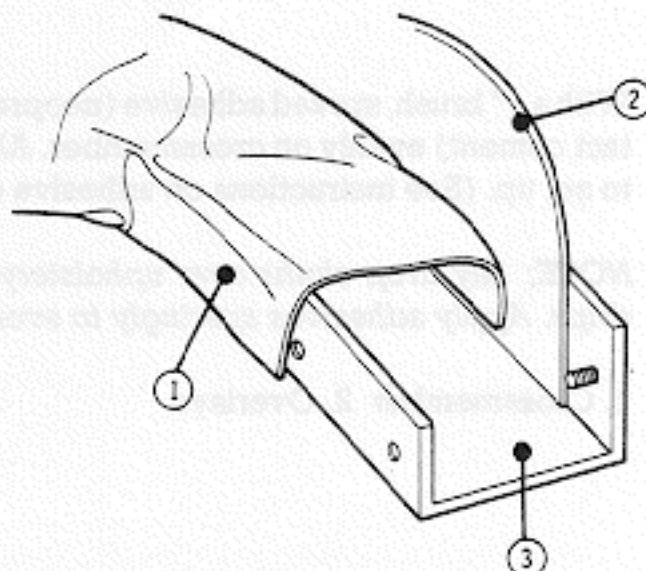

Top fabric and vinyl trim on water channel studs.

TOP INSTALLATION

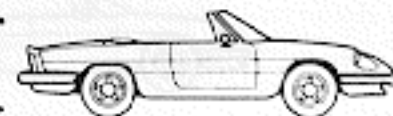

Reinstall center, left, and right retainer strips over both vinyl trim and top fabric on studs.

Replace the twenty-two 8 mm nuts on water channel studs.

NOTE: Do not tighten nuts at this time.

1. Center retainer strip 2. Side retainer strip 3. Water channel 4. 8mm nut and washer

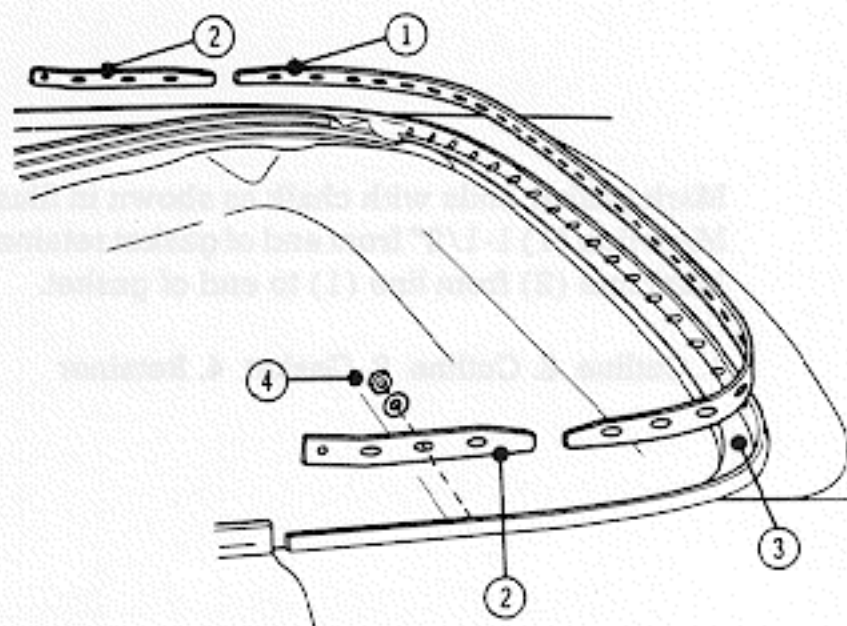

Proper position of retainer strips.

Gluing Fabric Overlays to Crossmembers

With top raised and latched, center the three crossmembers (1) in fabric overlays (2) inside top.

1. Crossmember 2. Overlays

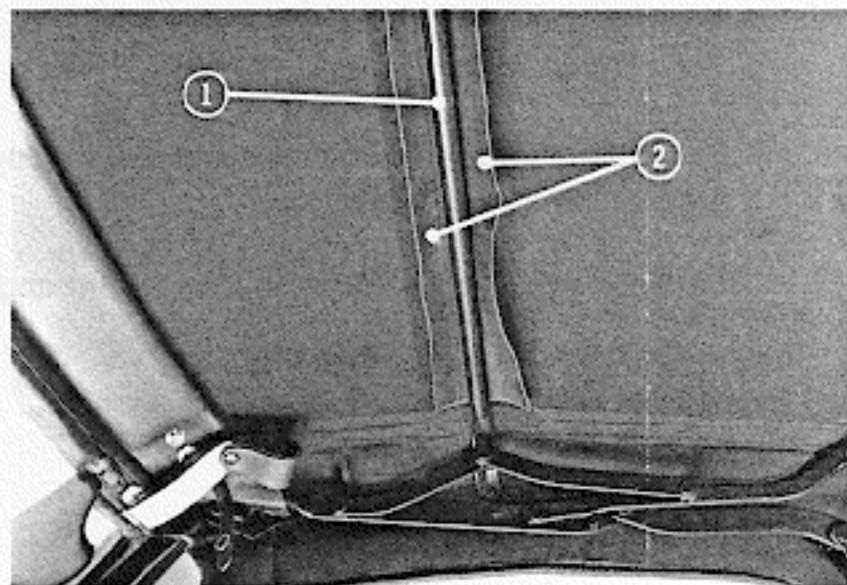

Crossmember centered in overlays.

With a 1" brush, spread adhesive (neoprene-base contact cement) evenly on crossmember. Allow adhesive to set up. (See instructions on adhesive container.)

NOTE: Lay drop cloths over upholstery to catch any drips. Apply adhesives sparingly to avoid smearing.

1. Crossmember 2. Overlays

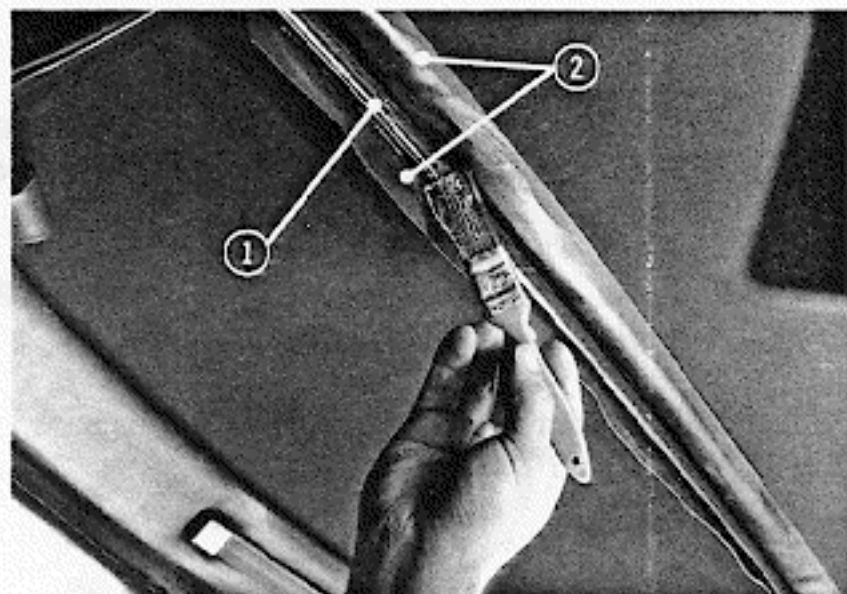

Brushing adhesive on crossmember.

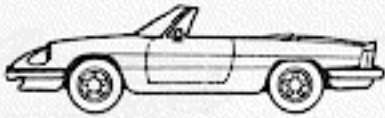

TOP INSTALLATION

Overlays must be folded over crossmembers in the order shown. This will hide seams from view.

1. First fold 2. Second fold

With a 1" brush, spread adhesive (neoprene-base contact cement) evenly on overlays. Fully coat each overlay.

Allow adhesive to set up.

Fold first overlay over crossmember, working from middle to outer ends.

Fold second overlay over first overlay and crossmember.

NOTE: Do not pull down on overlays when gluing them to crossmembers. This may create dimples in top.

1. First overlay 2. Second overlay

Smooth out any wrinkles and air bubbles in overlays. Properly bonded, the overlays will be securely fastened to crossmembers with straight seams and no loose edges.

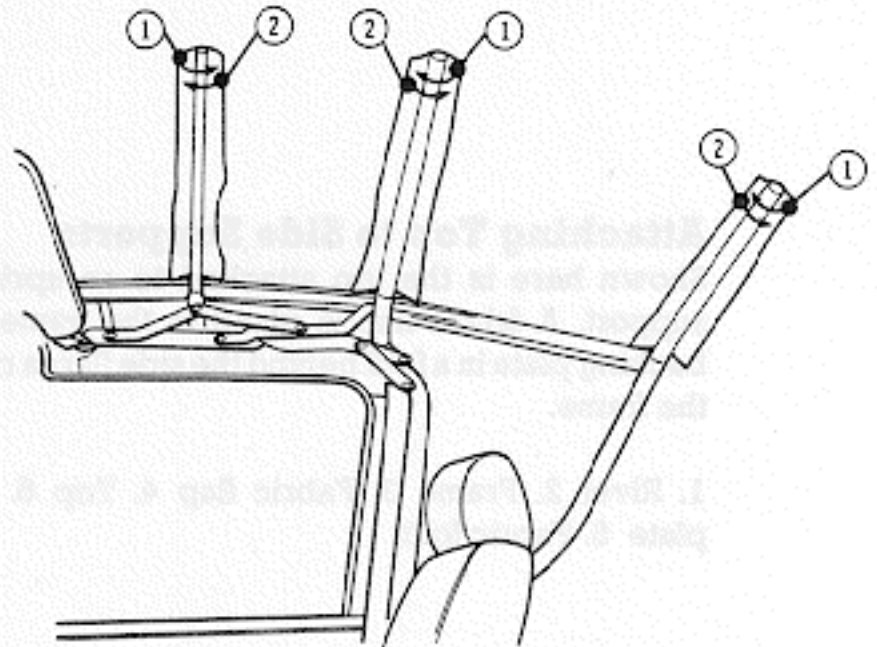

Fold overlays in this order.

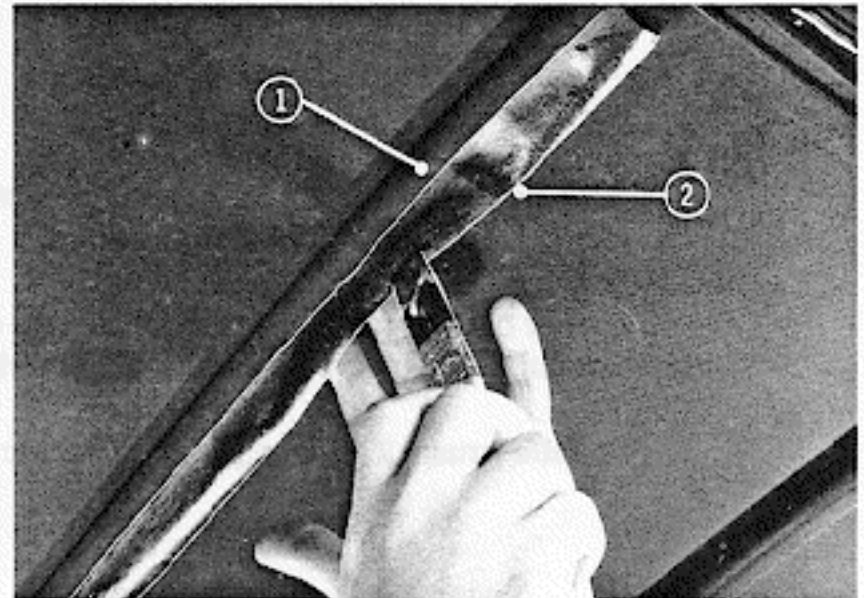

Folding flaps over crossmember.

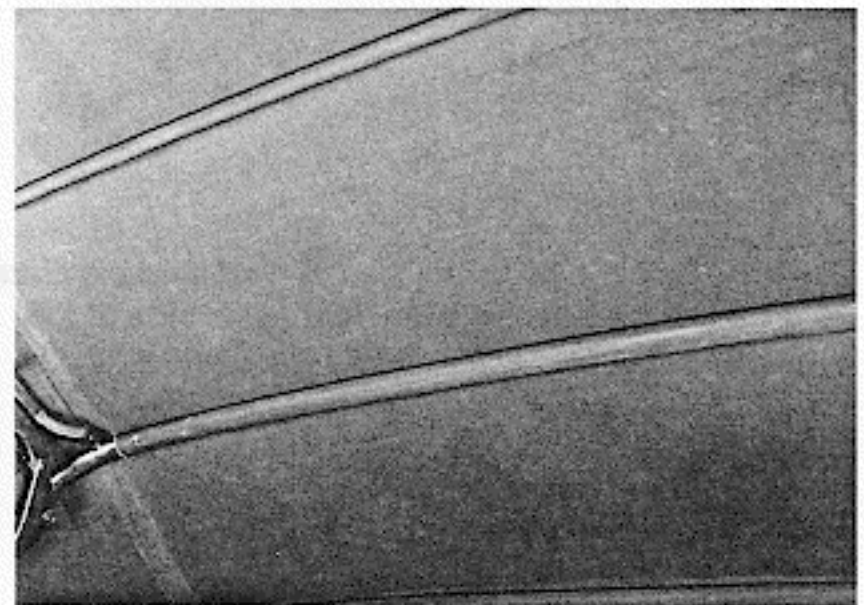

Overlays glued to crossmembers.

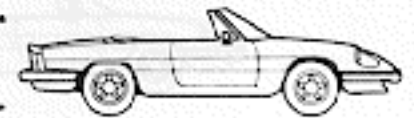

Attaching Top to Side Supports

Shown here is the top attached to an upright side support. A fabric flap is glued to the frame. A rivet backing plate in a fold behind the side flap is riveted to the frame.

1. Rivet
2. Frame
3. Fabric flap
4. Top
5. Backing plate
6. Fabric fold

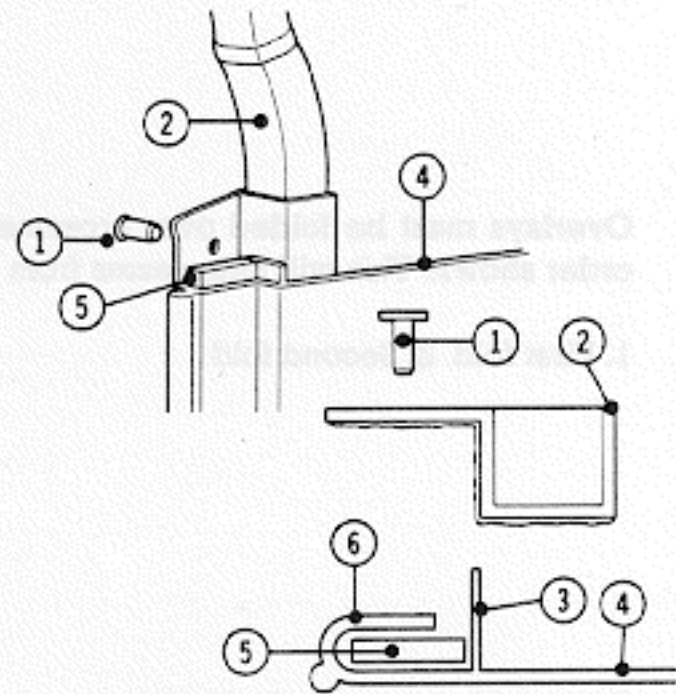

Side support and top attachment.

Use a 1" bristle brush (1) to apply adhesive to side support (2), and allow adhesive to set up.

Pull corner of top taut, and press fabric flap onto side support. Smooth out any air bubbles and wrinkles.

1. 1" bristle brush
2. Side support
3. Fabric flap

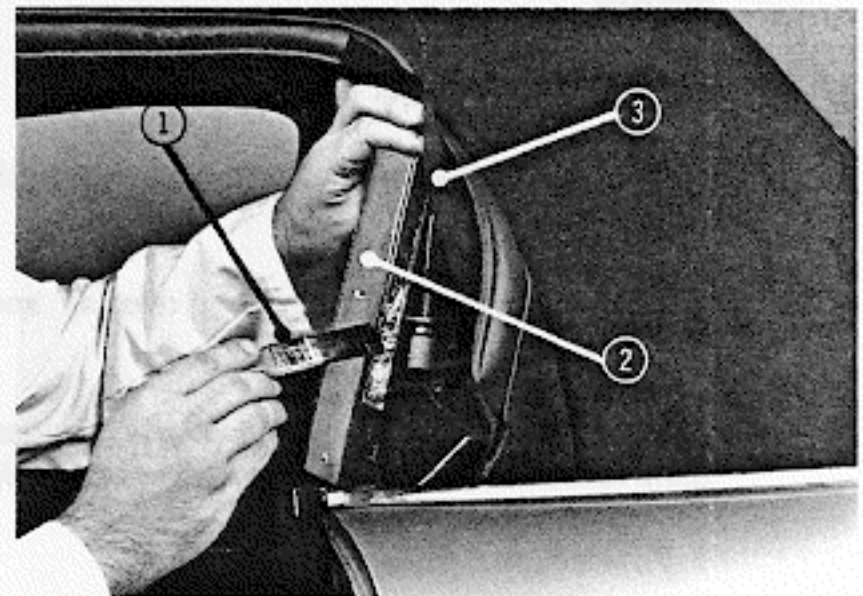

Applying glue to side support.

Apply glue to one side of rivet backing plate (1), and tuck plate into fabric fold (2) in side of top.

1. Rivet backing plate
2. Fabric fold

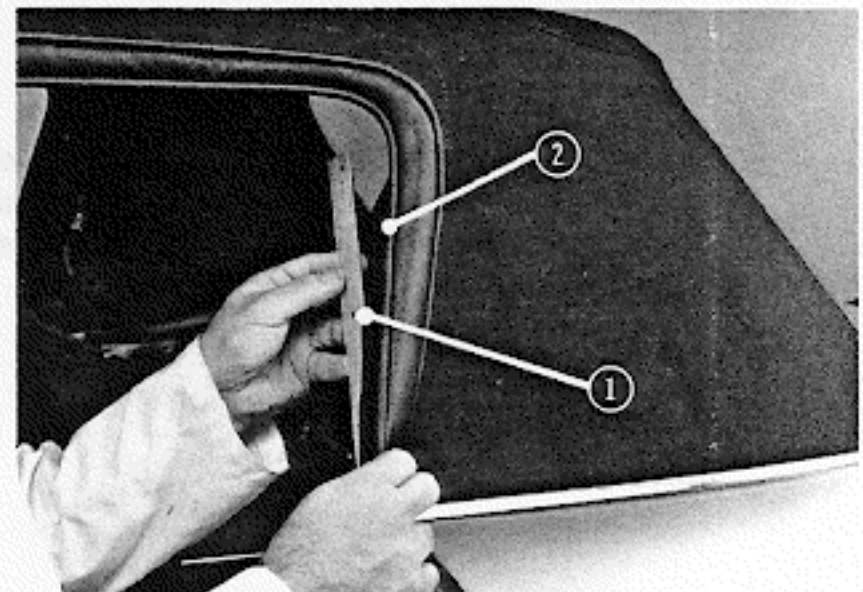

Placing backing plate into fabric fold.



TOP INSTALLATION

Press rivet backing plate against frame support.

Use an awl to align holes in side support with holes in backing plate.

Attach backing plate and top to side support with three 1/8" pop rivets.

Repeat this procedure to attach other side of top to side support.

1. Edge flap 2. Pop rivet gun

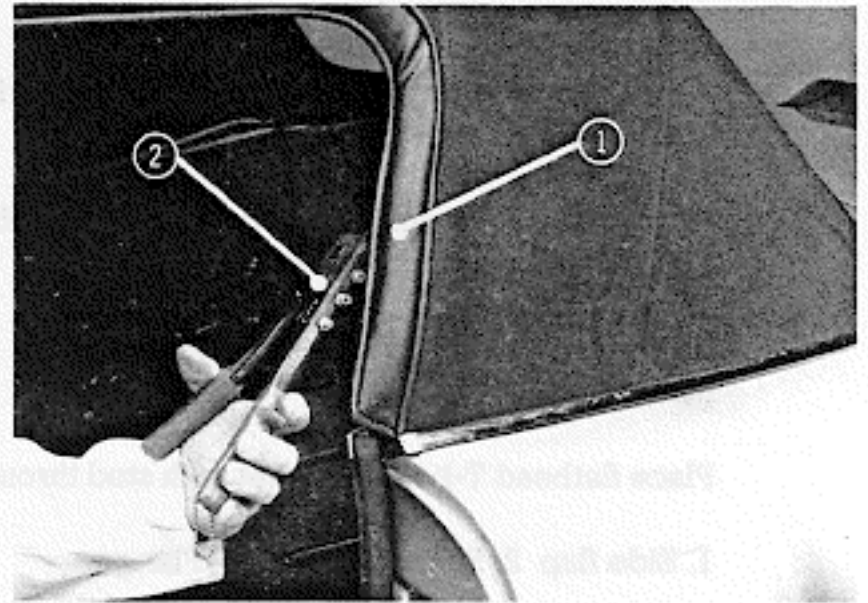

Riveting top to side support.

Attaching Front Corners of Top

Use an awl (2) to locate front corner rivet hole in frame through top fabric (3).

With top raised but unlatched, pull side flap (4) forward, and puncture a hole through inside of flap in line with front corner rivet hole.

With awl through flap and rivet hole, latch roof and check for proper alignment. Flap must extend over windshield post gasket.

1. Gasket 2. Awl 3. Top fabric 4. Side flap

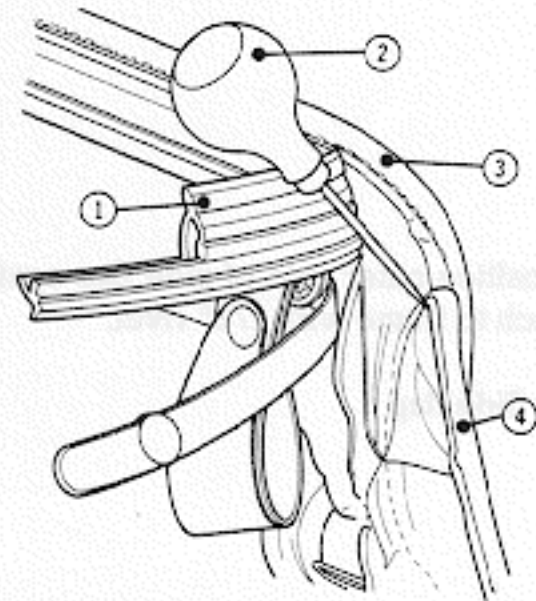

Aligning side flap with front corner rivet hole.

Use an awl to locate front corner bolt hole in metal flange (1) through top fabric.

Fold end of gasket (2) over hole and puncture gasket with awl (3).

1. Metal flange 2. Gasket 3. Awl

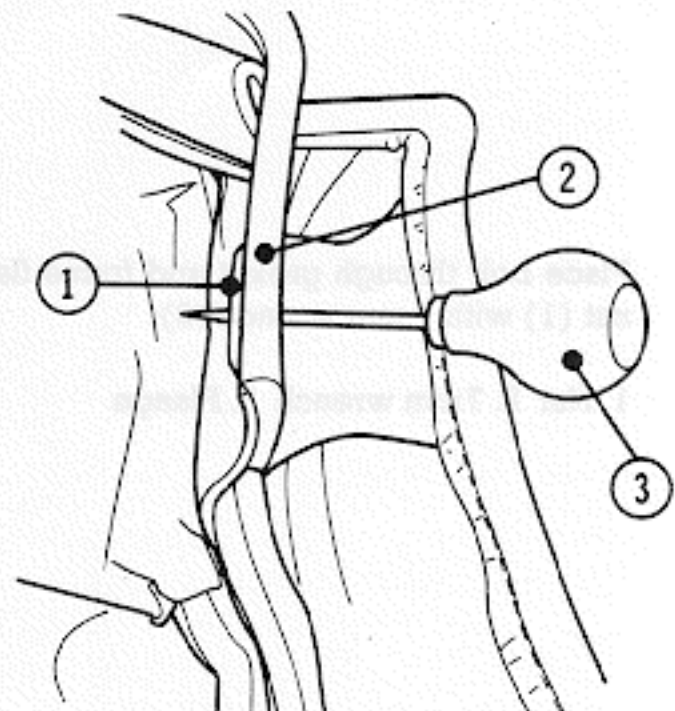

Aligning gasket with flange.

TOP INSTALLATION

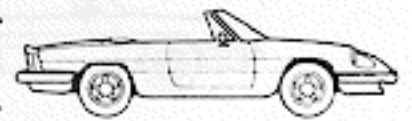

Again, stretch side flap forward (1), aligning rivet hole in flap with rivet in frame.

Approximate the position of bolt hole through pocket (2) in flap. Puncture hole with awl (3).

Insert awl inside pocket, and punch hole through material.

Place flathead T-bolt in pocket with stud through hole.

1. Side flap
2. Pocket
3. Awl
4. Flange

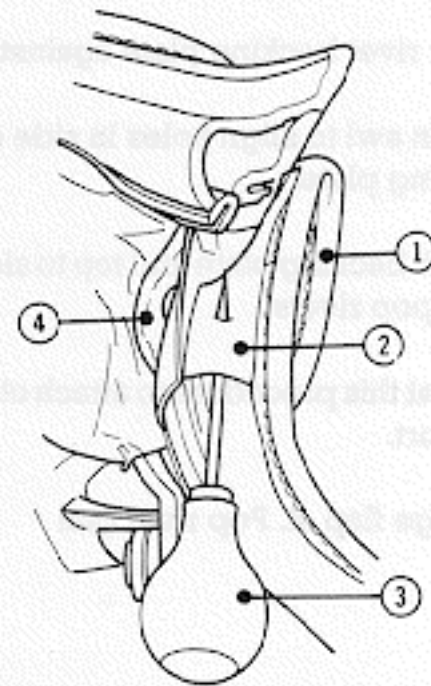

Puncturing hole in side flap pocket.

Position outer side of side flap against frame, and attach to frame with 1/8" rivet.

1. Side flap

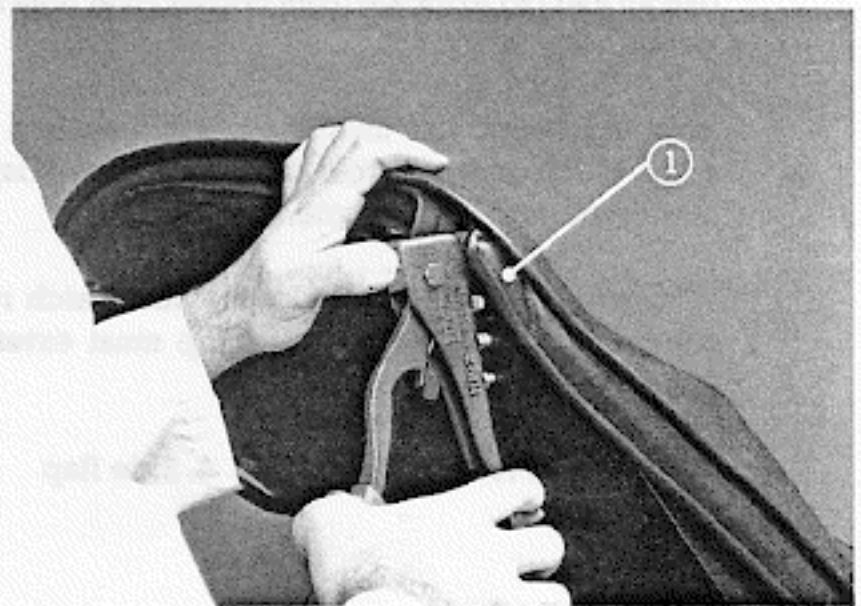

Riveting flap to frame.

Place bolt through gasket and frame flange. Tighten nut (1) with 7 mm wrench (2).

1. Nut
2. 7mm wrench
3. Flange

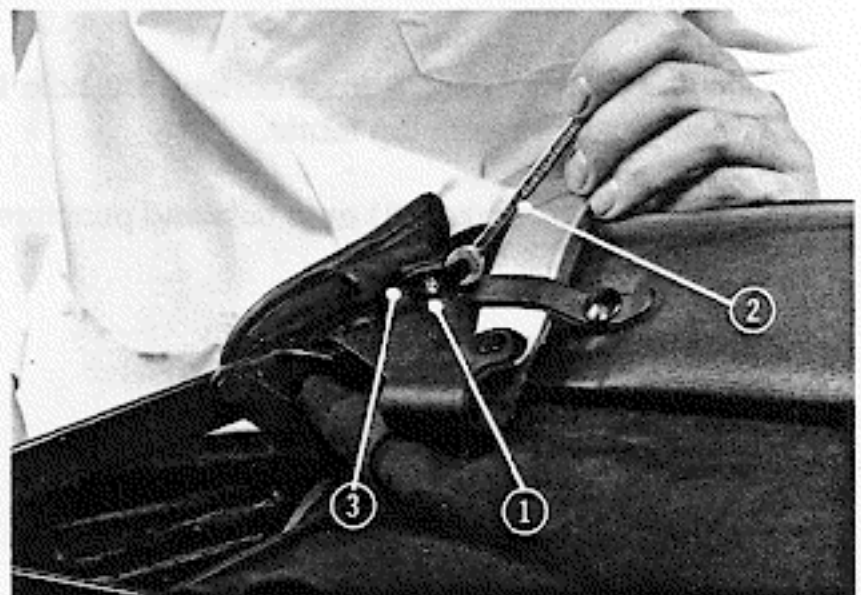

Bolting flap to frame.

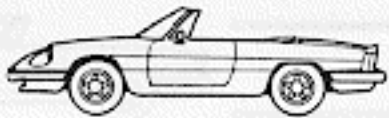

Securing Retainer Strips

Raise and latch top.

Use an awl to locate hole in frame for front screw in side retainer strip (2).

Insert screw (1) and tighten with Phillips screwdriver (3).

Follow this procedure for both left and right retainer strips.

1. Screw 2. Side retainer strip 3. Phillips screwdriver

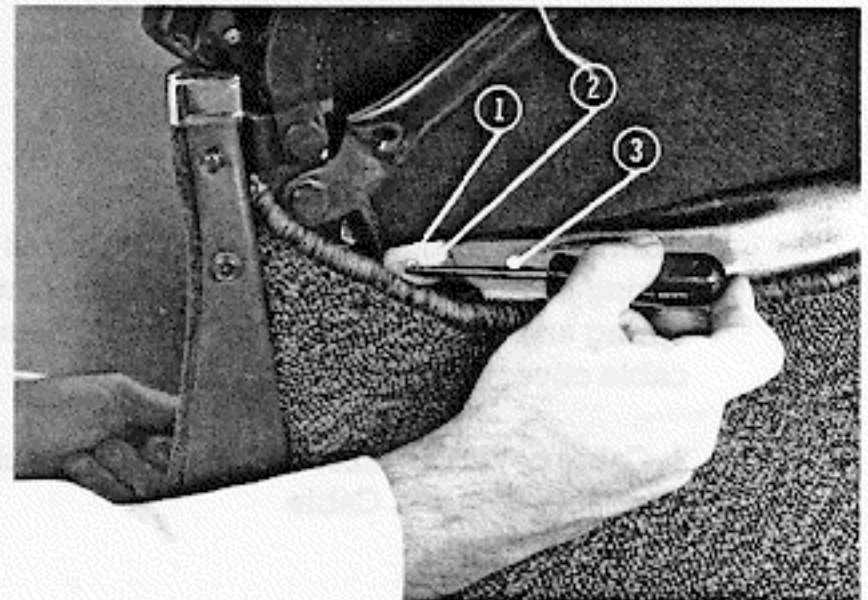

Screwing side retainer strips to frame.

Use an 8 mm wrench or nut driver (2) to tighten twenty-two nuts (1) securing retainer strips (3) to water channel.

1. Nut 2. Nut driver 3. Retainer strip

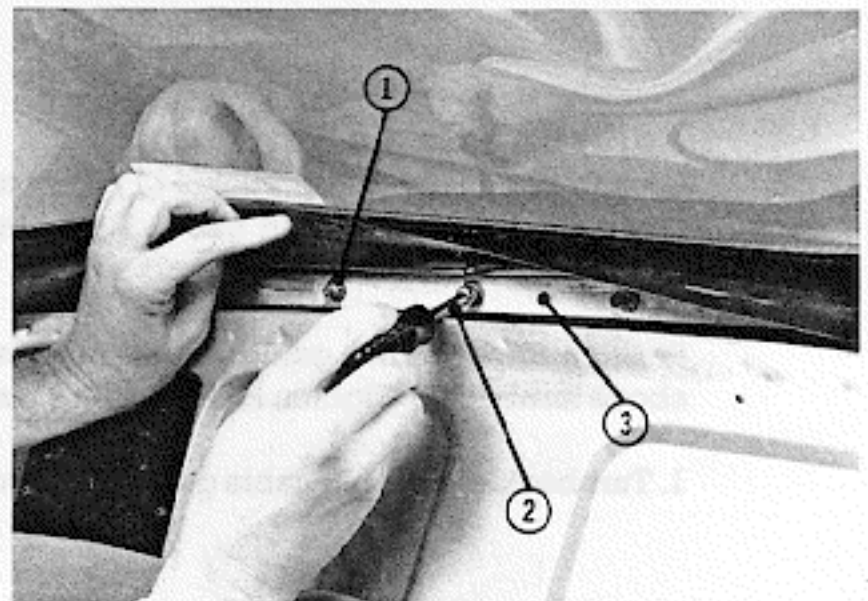

Tightening retainer strips.

Line up holes in vinyl flap with holes in front edge of water channel. Lift carpet (1) into position and attach with eight screws (2).

1. Carpet 2. Carpet retaining screw

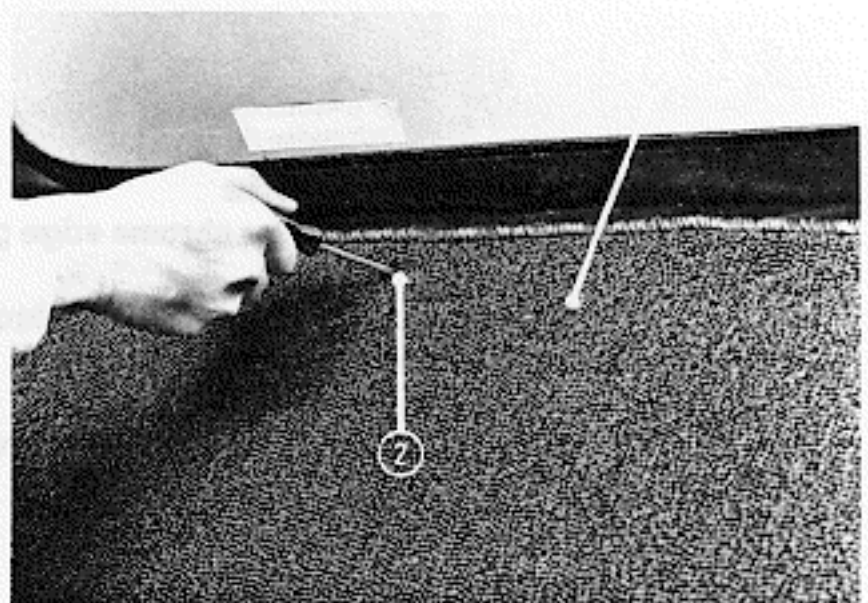

Attaching carpet.

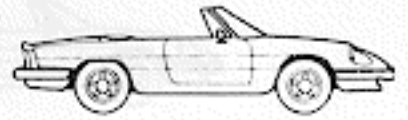

Reassembling Turnbuckles

Slide upper cable guide (4) onto cable (5).

Insert cable through turnbuckle (3). Install tensioner spring and cable locknut (2). Position locknut against spring and tighten with 7 mm wrench. Reinstall vinyl cable cover (1).

1. Cable cover 2. Cable locknut 3. Turnbuckle 4. Upper cable guide 5. Cable

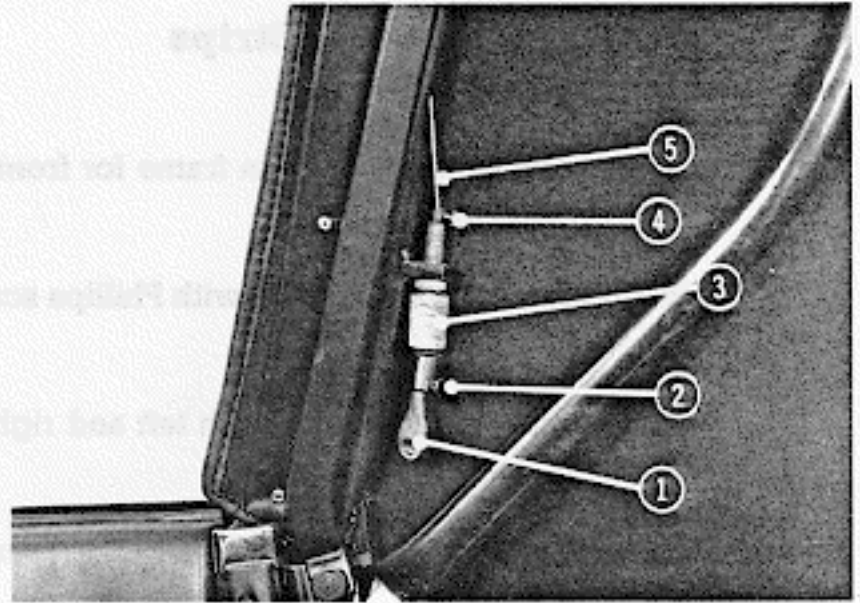

Reassembling turnbuckle.

Adjusting Cable Tension

Loosen 12 mm nut on turnbuckle (1). Turn turnbuckle down by hand to tension cable. Retighten 12 mm locknut.

Position upper cable guide (2) approximately 1/2" above turnbuckle. Tighten locknut with 7 mm wrench.

1. Turnbuckle 2. Upper cable guide 3. 12 mm wrench

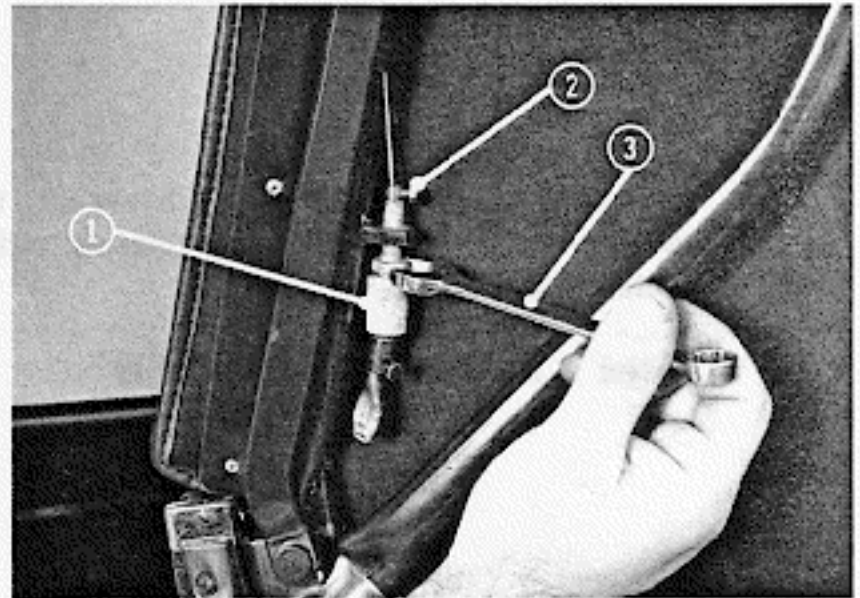

Locking turnbuckle.

Attaching Edge Guide

Use an awl to locate hole for chrome edge guide.

Use a Phillips screwdriver to attach chrome edge guide to frame side support.

1. Chrome edge guide 2. Phillips screwdriver

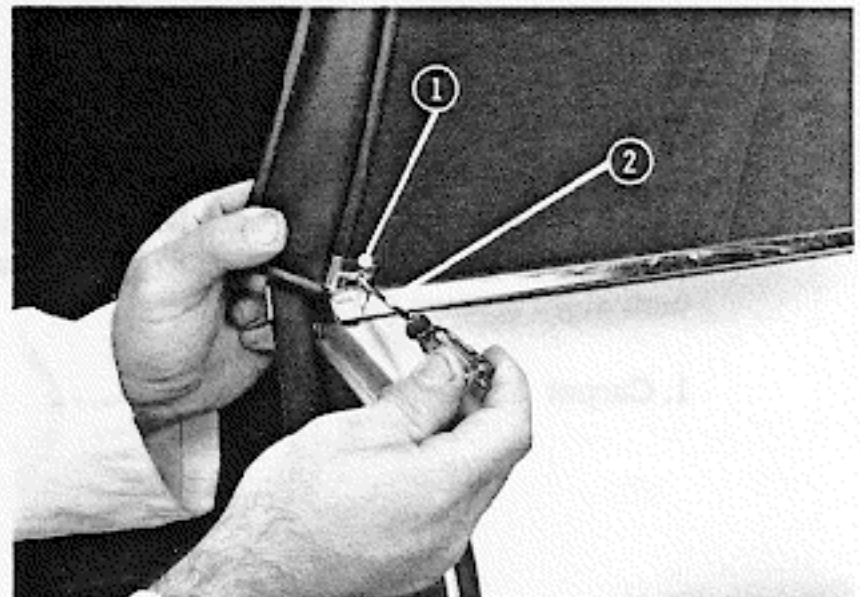

Replacing chrome edge guide.

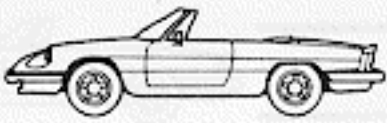

TOP INSTALLATION

The guides are tapered to fit angled window lines. Place left and right guides on corresponding sides of top.

1. Side flap
2. Top piping
3. Right edge guide

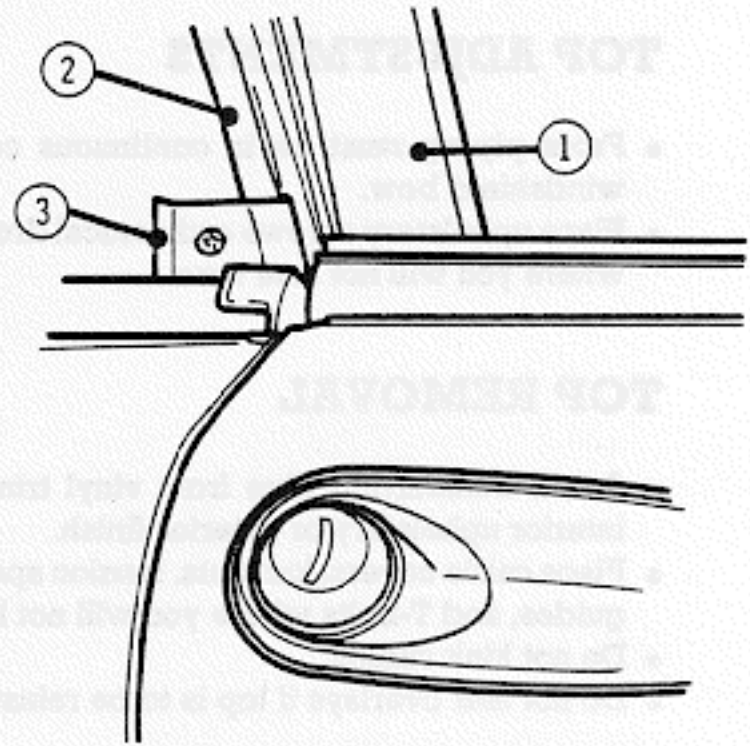

Right edge guide installed.

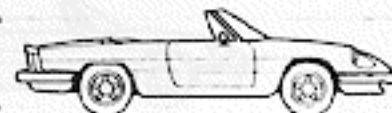

TOP ADJUSTMENTS

- Front piping must be in continuous contact with windshield bow.
- Place upholstery screws and conical dress washers where you will not lose them.

TOP REMOVAL

- Avoid transferring glue from vinyl trim pieces to interior upholstery or exterior finish.
- Place cable covers, locknuts, tension springs, cable guides, and T-bolts where you will not lose them.
- Do not kink cables.
- Do not tear overlays if top is to be reinstalled.

TOP INSTALLATION

- Do not apply excessive adhesive to front edge of frame and crossmembers. Runout will stain upholstery.
- Allow glue to set up before adhering overlays to crossmembers.
- Rivet heads in gasket retainer must be fully seated. Raised rivets will snag and damage gasket.
- Adhesive should be neoprene-base contact cement. Example: Weldwood Contact Cement #0105 or Goodyear Pliobond.