



**ALFA
ROMEO**

1750 BERLINA

1750 GT VELOCE[®]

1750 SPIDER VELOCE[®]

INIEZIONE

OWNER'S MANUAL

IMPORTANT NOTE

The fuel injection system for the 1750 model has been designed not only to attain high performance and low fuel consumption but also to keep the exhaust emissions below the levels permitted by U.S.A. regulations.

The low exhaust emission levels have therefore been obtained by improving the distribution and the combustion. No devices to burn the unburned gases downstream of the exhaust valves are required. Of course, even with the fuel injection system fitted to the Alfa 1750, the exhaust emissions will not continue to meet U.S. specification unless the owner himself provides to have the prescribed servicing regularly carried out by authorized Alfa Romeo Dealers and provided that, when remedying troubles or performing any maintenance work on the engine or fuel feed system, the factory prescribed procedures are strictly followed.

It is a good rule to keep a note of the symbol stamped on the key handle.

Ignition and antitheft device key

SYMBOL



Key to driver's and passenger's door, glove compartment, trunk lid

SYMBOL



When ordering duplicate keys, **please quote the symbol.**



The operation and maintenance instructions contained in this manual, particularly as far as the efficiency of the fuel injection system is concerned,

MUST BE CAREFULLY OBSERVED

by every owner who desires to get the best from his vehicle and to ensure a long life for every component.

Owners are recommended, in their own interest, to entrust all maintenance and repair work to an authorized Alfa Romeo Dealer as such Dealers are equipped with the proper tools and staffed by specially trained mechanics.

Owners are reminded that Alfa Romeo cannot be responsible for any errors made by unauthorized service stations or for any damage resulting from the use of nongenuine spare parts and/or lubricants other than those recommended.

Direzione Assistenza

The data relating to weights, consumptions and speeds are approximate only; Alfa Romeo reserves the right to change without notice any features and data given in this manual.



Alfa Romeo take steps to ensure the optimum performance of their cars by providing Owners with special services during the entire life of their vehicles.

The **Service Coupon Book**, supplied with every new vehicle, bears the conditions that govern the provision of Alfa Romeo Services and the replacement of damaged parts during the period covered by the warranty.

Every Owner of an Alfa Romeo motorcar is supplied with two coupons covering certain free maintenance during the warranty period, and he **must use these coupons on completion of the mileage as stated thereon.**

The labor cost of the maintenance work listed on the coupons is free, but the lubricants and the filtering elements used are to Owner's account. Any work not covered by free coupons but found necessary during the inspection will be subject to the General Terms of Warranty. The coupons should be used whenever possible at the garage of the Dealer that sold the car and during normal working hours.



WARRANTY

The Dealer warrants the products of the Factory for 6 months from the date of delivery to the Owner; the warranty does not cover tires and non-essential accessories if made by third parties, nor does it cover spare parts.

The warranty covers the free repair of, or free supply and replacement of, any parts found to be unserviceable **because of an acknowledged defect of materials**; defects will be acknowledged after prior investigation of them and of their causes exclusively by the manufacturer's workshops or by workshops authorized by the manufacturer, and at the said workshops.

Should the Purchaser insist on the services of an Alfa Romeo technician for the purpose of inspecting faulty or allegedly faulty parts, the expenses of such a technician will be the responsibility of the Purchaser.

Delays, if any, shall not entitle the Purchaser to receive compensation for damages, nor to any extension of his rights under the warranty.

The warranty shall lapse automatically:

if the products are used otherwise than in accordance with the manufacturer's instructions;

if they are modified, repaired or disassembled elsewhere than in the manufacturer's workshops or workshops authorized by the manufacturer;

if bodies of different origin which have not been previously approved by the manufacturer are fitted to the chassis.

The Purchaser shall not be entitled, in any of the cases stipulated by this article, to claim cancellation of the Contract or compensation for damages.

Contents

2 Service Coupon Book

3 Warranty

5 Identification

Specification:

8 Berlina

10 GT Veloce

12 Spider Veloce

Controls and instruments:

14 Berlina

16 GT Veloce

18 Spider Veloce

20 Breaking in

HOW TO USE YOUR CAR

21 Starting the engine - antitheft

22 Starting the engine (from cold, when hot)

23 Light switch

25 Precautions (while driving & parking)

26 Temperature setting

27 Winter precautions

Ventilation, demisting and heating:

28 Berlina

32 GT Veloce

36 Spider Veloce

38 Interior: Berlina

43 Safety belts

44 Interior: GT Veloce

48 Interior: Spider Veloce

52 Folding top: Spider Veloce

54 Wheel removal

55 Towing

LUBRICATION

56 Regular lubrication schedule

57 Regular lubrication and recommended lubricants

58 Engine

59 Oil pump and filter

MAINTENANCE

60 Regular maintenance schedule

61 Regular maintenance

ENGINE MAINTENANCE

62 Tightening torque specifications

63 Valve timing

65 Fuel injection

66 Injection system diagram

69 Air cleaner

70 Fuel filters

71 Trouble shooting

72 Ignition

76 Cooling system

CHASSIS MAINTENANCE

80 Clutch

82 Transmission

83 Drive shaft

84 Rear axle

85 Front suspension

86 Rear suspension

87 Steering gear and linkage

88 Front wheels (toe in)

89 Front wheels (camber)

90 Brakes

100 Wheel balancing

101 Tires inflation pressures

102 Tires changing over

103 BODY MAINTENANCE

104 LAYING THE CAR UP PRECAUTIONS

ELECTRICAL SYSTEM

105 Battery

106 Alternator, starter

107 Replacing a lamp or bulb

110 Headlamp beam setting

111 Wiring diagrams

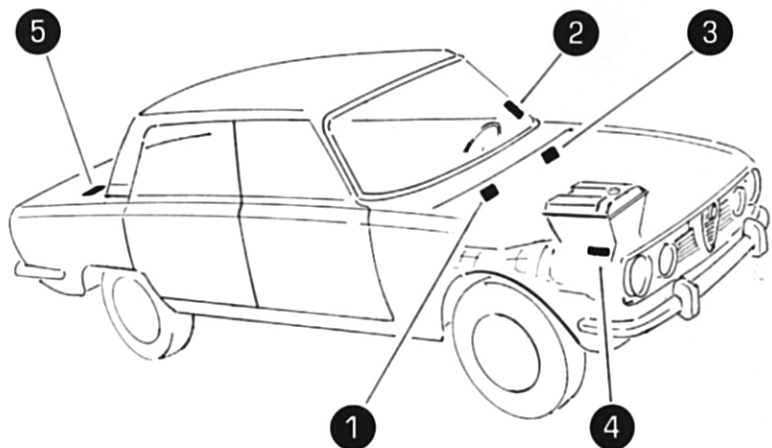

Chassis no. (1 on firewall
(2 on windshield post

- 3 Car model no. on firewall
- 4 Engine no. on crankcase R.H. side
- 5 Finish plate (paint type & make) on trunk lid

On contacting the Factory or a Member of our Service Organization please state: car model no., chassis no., registration date, distance covered and car's purchase data.





1750 BERLINA



1750 GT VELOCE[®]

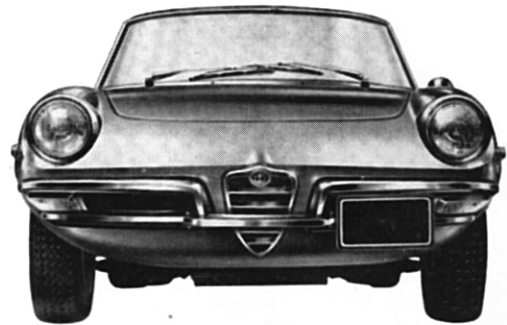

1750 SPIDER VELOCE[®]



Specification

Engine	Number and layout of cylinders	4 in line
	Bore and stroke	80 x 88.5 mm
	Total displacement	1779 cc.
	BHP @ 5500 rpm	132 SAE

Chassis	Turning circle	36.5 ft
	Designated seating capacity	4
	Tires (Kleber Colombes V 10 - Michelin ZX - Pirelli Cinturato SR)	165 R 14
	Curb weight	2442 lbs

Fuel, oil and coolant

Cooling system:		
Alfa Romeo coolant mixture	abt.	2.5 gals
Fuel	"	12 gals
For best engine performance the use of premium grade fuel is advised.		
Fuel reserve	abt.	1.6-1.8 gals
OIL	Engine (pan and filter)	
	when full ★	7.1 qts
	danger level	4.75 qts
	Transmission	3.8 pts
	Differential	3.0 pts
	Steering box6 pt
	★ This quantity is that needed for regular changing. The total amount of oil in the circuit (pan, filter and passages) is	7.8 qts

PERFORMANCE
with 41 : 9
final drive

GEAR	AFTER BREAKING IN mph.
1st	28
2nd	46
3rd	68
4th	91
5th	112
Rev.	30

The maximum speeds indicated should not be exceeded or mechanical damage may result.

The performances given are related to the use of the vehicle in average travelling conditions.

1750 BERLINA

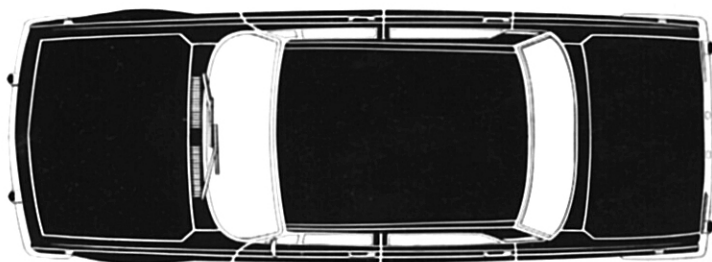
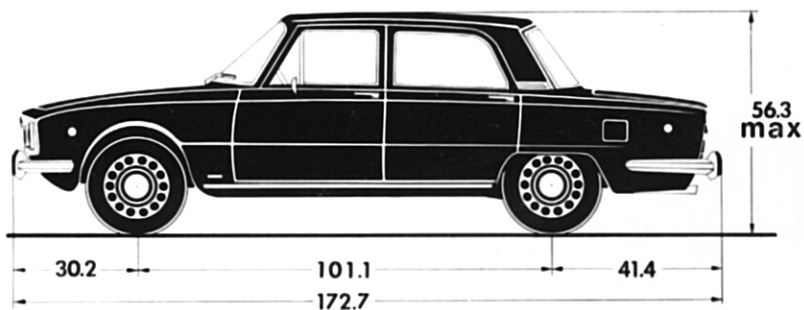

Dimensions in inches - overall height with unladen car



Specification

Engine	Number and layout of cylinders	4 in line
	Bore and stroke	80 x 88.5 mm
	Total displacement	1779 cc.
	BHP @ 5500 rpm	132 SAE

Chassis	Turning circle	34.8 ft
	Designated seating capacity	2
	Tires (Kleber Colombes V10 GT - Michelin XAS - Pirelli Cinturato HR)	165 R 14
	Curb weight	2292 lbs

**Fuel, oil
and coolant**

Cooling system:		
	Alfa Romeo coolant mixture abt.	2.5 gals
	Fuel	12 gals
	For best engine performance the use of premium grade fuel is advised.	
	Fuel reserve abt.	1.6-1.8 gals
OIL	Engine (pan and filter)	
	when full ★	7.1 qts
	danger level	4.75 qts
	Transmission	3.8 pts
	Differential	3.0 pts
	Steering box6 pt
	★ This quantity is that needed for regular changing. The total amount of oil in the circuit (pan, filter and passages) is	7.8 qts

PERFORMANCE
with 41 : 9
final drive

GEAR	AFTER BREAKING IN mph.
1st	29
2nd	48
3rd	71
4th	99
5th	118
Rev.	32

The maximum speeds indicated should not be exceeded or mechanical damage may result.

The performances given are related to the use of the vehicle in average travelling conditions.

1750 GT VELOCE[®]

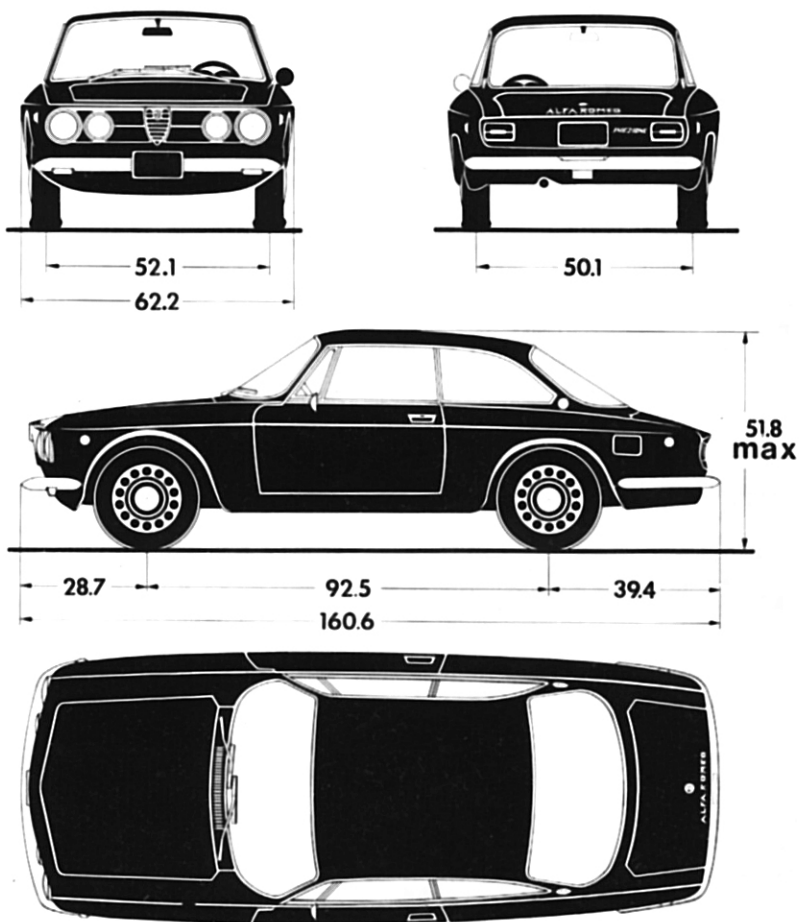

Dimensions in inches - overall height with unladen car.



Specification

Engine	Number and layout of cylinders	4 in line
	Bore and stroke	80 x 88.5 mm
	Total displacement	1779 cc.
	BHP @ 5500 rpm	132 SAE

Chassis	Turning circle	34.5 ft
	Designated seating capacity	2
	Tires (Kleber Colombes V10 GT - Michelin XAS - Pirelli Cinturato HR)	165 R 14
	Curb weight	2292 lbs

Fuel, oil and coolant	Cooling system:		
	Alfa Romeo coolant mixture	abt. 2.5 gals	
	Fuel	12 gals	
	For best engine performance the use of premium grade fuel is advised.		
	Fuel reserve	abt. 1.6-1.8 gals	
	OIL	Engine (pan and filter)	
		when full ★	7.1 qts
		danger level	4.75 qts
		Transmission	3.8 pts
		Differential	3.0 pts
Steering box6 pt	
★ This quantity is that needed for regular changing. The total amount of oil in the circuit (pan, filter and passages) is		7.8 qts	

PERFORMANCE
with 41 : 9
final drive

GEAR	AFTER BREAKING IN mph.
1st	29
2nd	48
3rd	71
4th	99
5th	118
Rev.	32

The maximum speeds indicated should not be exceeded or mechanical damage may result.

The performances given are related to the use of the vehicle in average travelling conditions.

1750 SPIDER VELOCE®

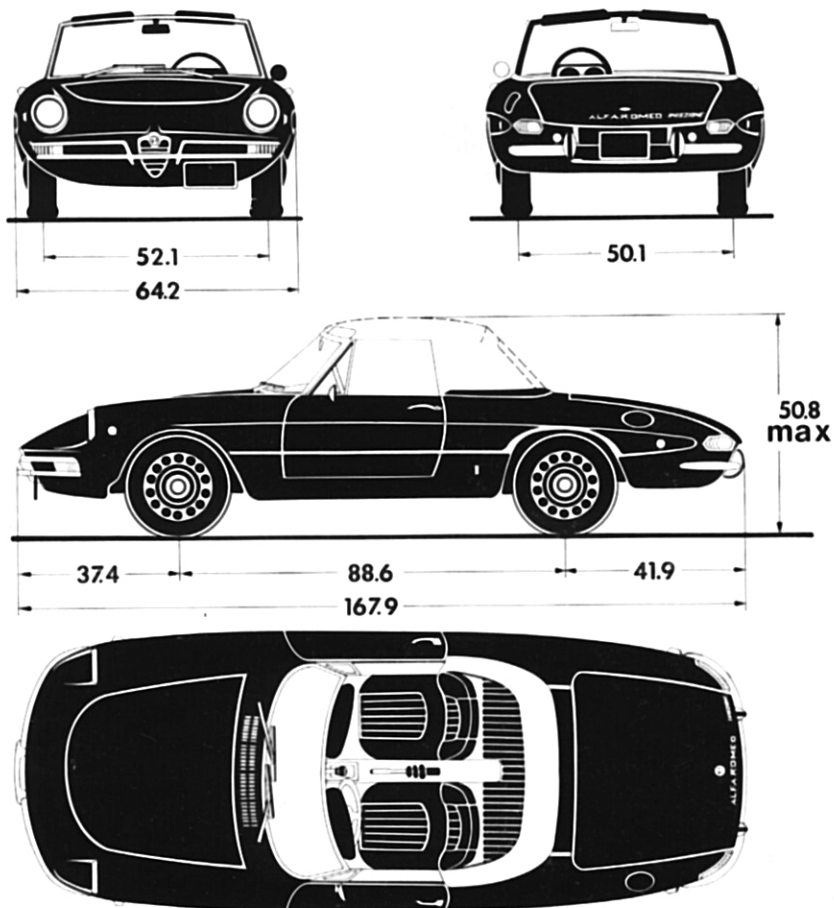

Dimensions in inches - overall height with unladen car.



Controls and instruments

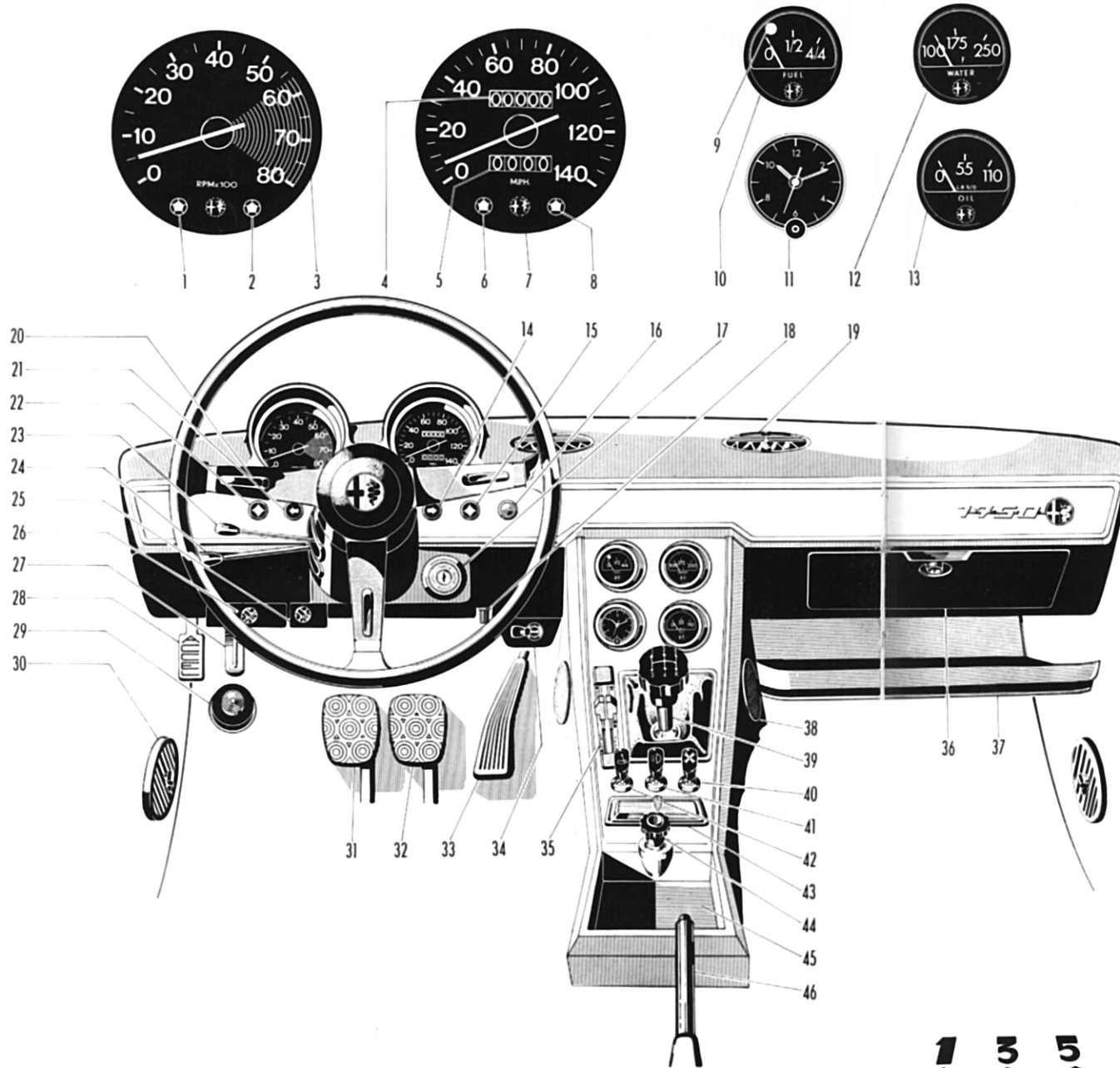

To engage the REVERSE merely shift the lever from neutral (F) as shown. ▶

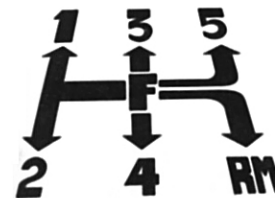

- 1 Blower warning light
- 2 Alternator warning light
- 3 Tachometer
- 4 Main odometer
- 5 Tripometer
- 6 Parking light warning
- 7 Speedometer
- 8 Headlamp high beam warning light
- 9 Fuel reserve warning light
- 10 Fuel level indicator
- 11 Electric clock
- 12 Coolant temperature indicator
- 13 Oil pressure gage
- 14 Warning light for R.H. direction indicator
- 15 Low oil pressure warning light. See page 59
- 16 Service brake warning light (push-to-test type). See page 91
- 21 Warning light for L.H. direction indicator
- 22 Low fuel pressure warning light. See pages 21 and 25
- 25 Additional fuse holder
- 26 Fusebox

- 17 Ignition switch & anti theft
- 18 Tripometer reset
- 20 Horn
- 23 Direction indicator switch
- 24 Headlamp, dimmer and flashing switch
- 27 Hood release
- 28 Hand throttle
- 29 Windshield washer: when the control is pressed the windshield wiper also comes into action
- 31 Clutch
- 32 Brake
- 33 Accelerator
- 34 Emergency flasher switch
- 35 Heating, ventilating and demisting
- 39 Gearshift lever
- 40 Blower switch (2-speed)
- 41 Fog lamp switch
- 42 Windshield wiper switch (2-speed)
- 46 Hand brake (for emergency and parking)

- 19 Windshield demisting outlet
- 30 Ventilating air outlet
- 36 Glove compartment
- 37 Shelf
- 38 Speaker compartment
- 43 Ash tray
- 44 Cigarette lighter: insert a cigarette then push the knob in: this brings into operation an electric element which lights the cigarette and turns itself off after a few seconds
- 45 Utility recess

Instruments

Controls

Luxury fittings



Controls and instruments

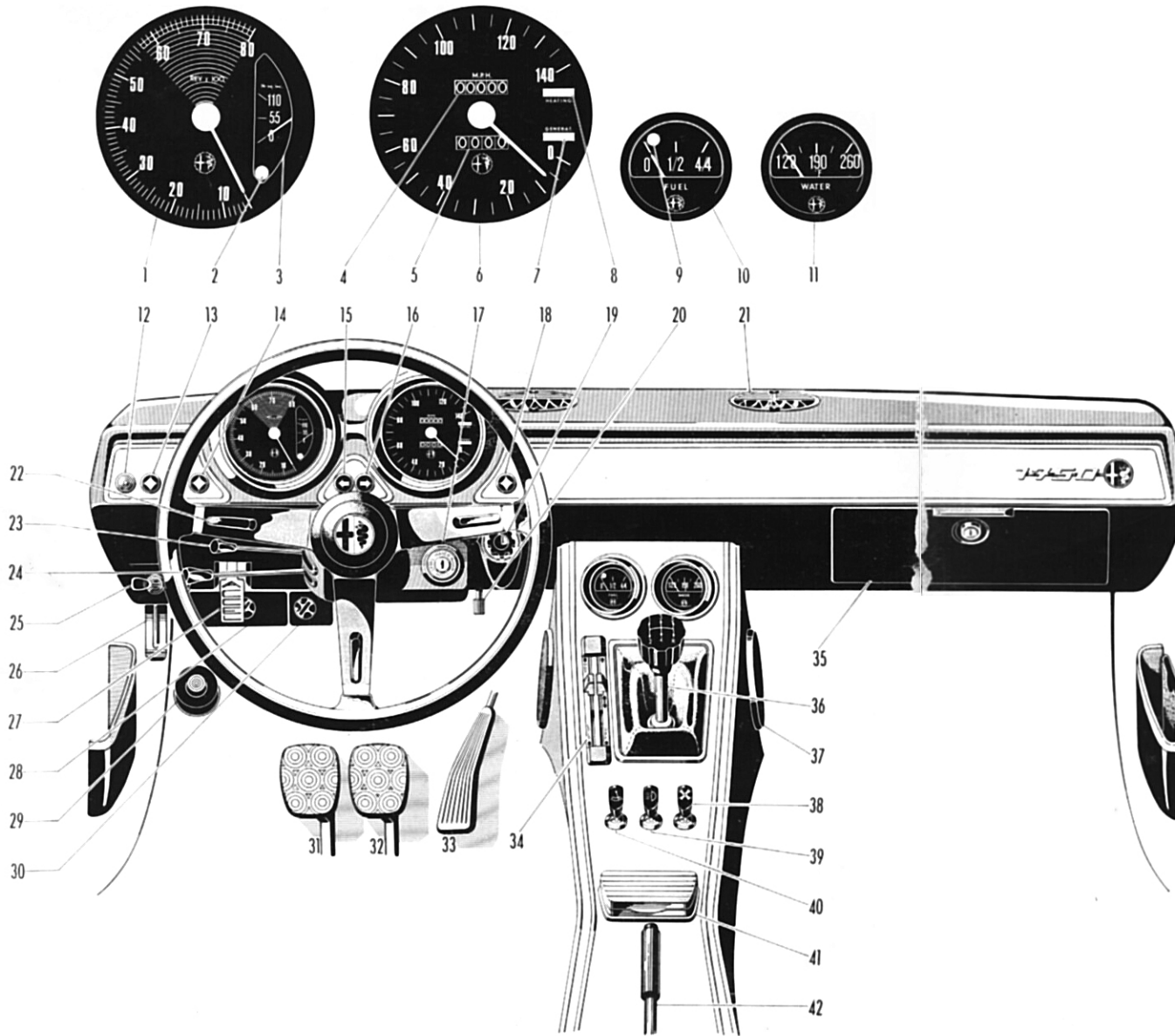

Instruments

- 1 Tachometer
- 2 Low oil pressure warning light. See page 59
- 3 Oil pressure gage
- 4 Main odometer
- 5 Tripometer
- 6 Speedometer
- 7 Alternator warning light
- 8 Heater blower warning light
- 9 Fuel reserve warning light
- 10 Fuel level indicator
- 11 Coolant temperature indicator
- 12 Service brake warning light (push-to-test type). See page 91
- 13 Low fuel pressure warning light. See pages 21 and 25
- 14 Parking light warning
- 15 Direction indicator warning light (left-hand)
- 16 Direction indicator warning light (right-hand)
- 18 Headlamp high beam warning light
- 28 Fusebox
- 30 Additional fuse holder

Controls

- 17 Ignition switch & anti theft
- 20 Tripometer reset
- 22 Horn
- 23 Direction indicator switch
- 24 Headlamp, dimmer & flashing switch
- 25 Emergency flasher switch
- 26 Hood release
- 27 Hand throttle
- 29 Windshield washer: when the control is pressed the windshield wiper also comes into action
- 31 Clutch
- 32 Brake
- 33 Accelerator
- 34 Heating, ventilating and demisting
- 36 Gearshift lever
- 38 Blower switch (two speed)
- 39 Fog lamp switch
- 40 Windshield wiper switch (two speed)
- 42 Hand brake (for emergency and parking)

Luxury fittings

- 19 Cigarette lighter: insert cigarette, press down outer edge of the lighter: this brings into operation an electric element which lights the cigarette and turns itself off after a few seconds
- 21 Air outlets (adjustable)
- 35 Glove compartment
- 37 Radio compartment
- 41 Ash tray

To engage the REVERSE merely shift the lever from neutral (F) as shown. ▶

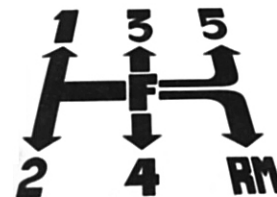

Controls and instruments

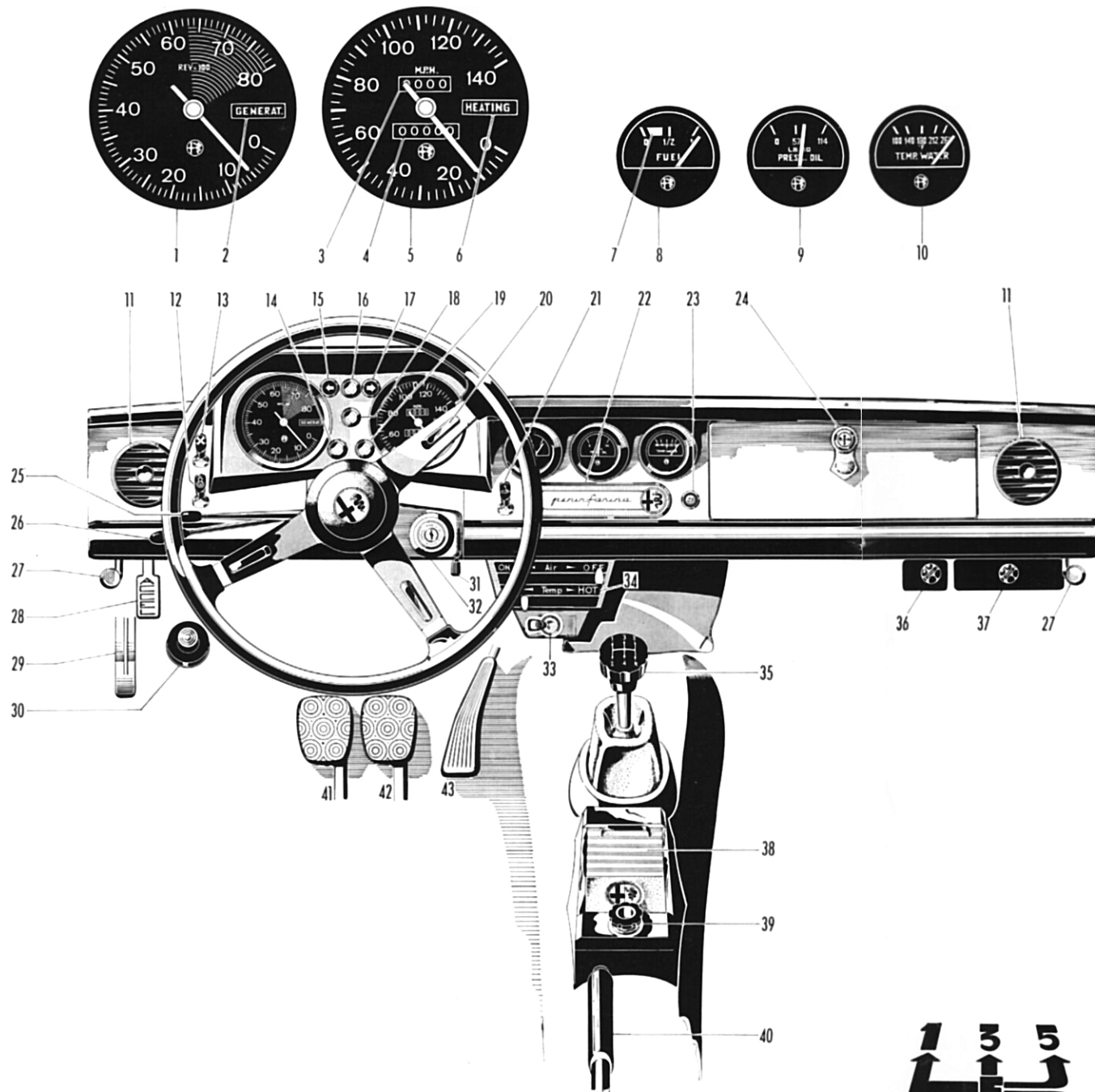

To engage the REVERSE merely shift the lever from neutral (F) as shown. ▶

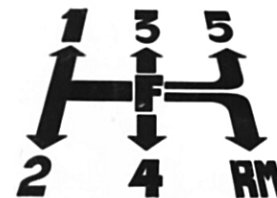

Instruments

- 1 Tachometer
- 2 Alternator warning light
- 3 Tripometer
- 4 Main odometer
- 5 Speedometer
- 6 Heater blower warning light
- 7 Fuel reserve warning light
- 8 Fuel level indicator
- 9 Oil pressure gage
- 10 Coolant temperature indicator
- 14 Parking light warning
- 15 Direction indicator warning light (left-hand)
- 16 Low oil pressure warning light. See page 59
- 17 Direction indicator warning light (right-hand)
- 18 Low fuel pressure warning light. See pages 21 and 25
- 19 Headlamp high beam warning light
- 23 Service brake warning light (push-to-test type). See page 91
- 36 Additional fuse holder
- 37 Fusebox

Controls

- 12 Dashboard light switch (acts only when parking lights are on)
- 13 Blower switch (2-speed)
- 20 Horn
- 21 Windshield wiper switch (2-speed)
- 25 Direction indicator switch
- 26 Headlamp, dimmer & flashing switch
- 28 Hand throttle
- 29 Hood release
- 30 Windshield washer: when the control is pressed the windshield wiper also comes into action
- 31 Tripometer reset
- 32 Ignition switch & anti theft
- 33 Emergency flasher switch
- 35 Gearshift lever
- 40 Hand brake (for emergency and parking)
- 41 Clutch
- 42 Brake
- 43 Accelerator

Luxury fittings

- 11 Air outlets (adjustable)
- 22 Radio compartment
- 24 Glove compartment
- 27 Side outlet lever
- 34 Heating, ventilating and demisting
- 38 Ash tray
- 39 Cigarette lighter: insert cigarette, press down outer edge of the lighter: this brings into operation an electric element which lights the cigarette and turns itself off after a few seconds.

**WARNING FOR
THE FIRST
1900 miles**

BREAKING IN

To allow the various parts of the car, **particularly the engine, transmission and differential**, to settle in gradually, a breaking in period is necessary, during which maximum performance must not be demanded of the car.

RECOMMENDATIONS FOR THE FIRST 1900 MILES

Mileage	Max. speeds mph				
	1st	2nd	3rd	4th	5th
Up to 600	17	29	42	57	72
601 to 1900	21	35	51	69	88

Cold starting:

— before driving, run engine at approx. 1500 rpm for at least 1 minute in summer and 2-3 minutes in winter.

While driving:

— do not drive at max. recommended speeds for long periods;
 — never fully depress the accelerator pedal;
 — now and then release the accelerator pedal;
 — avoid full and extended braking during the first 600 miles.

DURING BREAKING-IN STRICTLY FOLLOW THE ABOVE INSTRUCTIONS!

Note: The same recommendations apply also in the case of engine reconditioning involving the replacement of cylinder barrels, pistons, piston rings and bearings.



FREE SERVICE COUPONS

COUPON A
COUPON B

At the first **500-750 mi.** } carry out the free servicing included in
 At the first **3000-3750 mi.** } coupons

How to use your car



STARTING THE ENGINE

Make certain the gearshift lever is in neutral.

Insert the key in the ignition switch and turn it clockwise to the **MARCIA** position (ignition « on »); wait a few moments to **make sure the low fuel pressure warning light goes off**. For light location:

Berlina see 22 on page 15
GT Veloce see 13 on page 17
Spider Veloce see 18 on page 19

If the warning light does not flash on or stays on, this is an indication of failure of the indicating device or fuel feed system; therefore have them checked as soon as possible by an authorized Alfa Romeo Dealer.

Turn the ignition key further clockwise to **AVVIAM** to operate the starter. As soon as the engine fires release the key.

If the engine fails to start, the key must be returned to **GARAGE** and the operation repeated.



STOPPING THE ENGINE

Return the key to **GARAGE**. In such a position the ignition is « off » and the wheels can be steered even if the key is withdrawn.



ANTITHEFT DEVICE/STEERING LOCK

Turn the key back to **BLOCCO**. By withdrawing the key the steering is locked; to engage the lock properly, slightly rotate the wheel in both directions.

Never withdraw the key before the car has come to a complete stop as the « steering lock » condition may occur.

MARCIA = ignition; AVVIAM. = starting; BLOCCO = lock.



From cold

Particularly when starting from cold in winter, it is advisable, in order to facilitate starting, to press the clutch pedal down fully.

Automatic devices act as a standard choke usually does, namely, facilitate the initial running of engine after a cold start until the proper operating temperature is reached.

As an aid in starting from cold, depress, partially and progressively, the accelerator pedal. After a cold start and particularly when the room temperature is below freezing point, wait a fairly long time before getting away so as to warm up properly all engine parts and allow the oil to reach all points requiring lubrication.

Top performance must never be demanded of the car until coolant temperature is about 158 °F.

When hot

When the engine is already hot or with very high room temperatures (above 77 °F) slowly depress the accelerator pedal to facilitate starting.

If the engine fails to start, look for the cause as follows:

- the battery charge may be too weak to rotate the starter sufficiently fast to start the engine;
- the ignition equipment may be defective (dirty plugs, oxidized contact-breaker points, wet or cracked distributor cap, damaged distributor or coil);
- the solenoid-actuated cold start device may fail to operate;
- electric circuits may be broken or fuses blown.

Do not accelerate the engine until it has warmed up, since when the engine is cold the oil cannot reach all points requiring lubrication.

Make sure the oil pressure shown by the gage is as prescribed and the oil pressure warning light goes off as soon as the engine speed exceeds idling.

Also make sure **the alternator warning light goes off** as engine exceed idling.

Check that the low fuel pressure warning light is off.

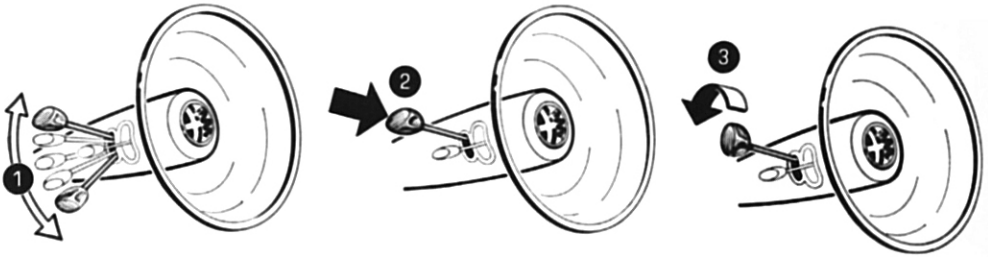

The switch lever may be in either of the two positions. The warning lights on the dashboard are out.

1 Lights off

Press on the knob irrespective of the position of the switch.

2 Flashing

Irrespective of the position of the lever, turn the knob to the first notch. The warning light on the dashboard will light up and flashing is still possible by pressing the knob.

On Berlina and GT Veloce the dashboard lights will come on as well.

3 Parking lights and license plate light

From position 3 turn the knob forward to the second notch.

If the lever is up, the **dimmed lights** come on (no flashing).

If on the other hand, it is down, the **beam lights** and the respective warning light come on (flashing possible).

The movement of the lever up and down allows the light to be **dimmed** or returned to **beam**.



The lights are extinguished by turning the knob back over the notches.

1 Lights off

**Emergency
(road hazard)
flashers**

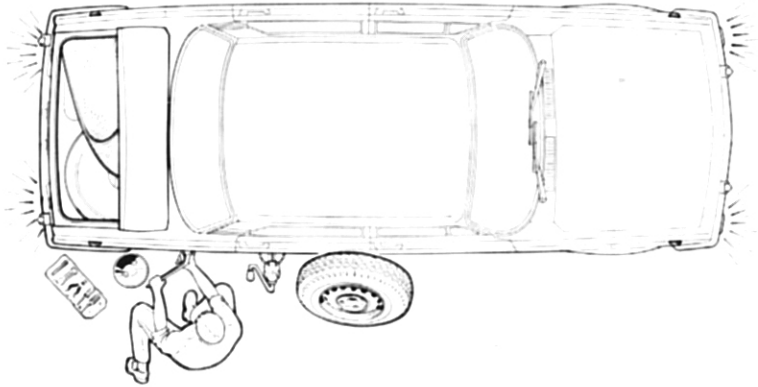

To operate the emergency flashing lights, which are wired independently from the ignition switch, act on the toggle switch mounted on the dashboard.



Fog lamps

The Berlina and GT Veloce are provided with fog lamps as standard equipment.

The lamps are controlled by the switch on the console when the parking lights are on.

Take care not to run the engine beyond the maximum R.P.M. Check the oil pressure gage from time to time and stop the engine if the pressure with a hot engine and at maximum revolutions should fall below limits shown on page 59.

While driving

Check the low oil pressure warning light: if on, it is an indication of a trouble in the lubricating system: in this case, stop the car and have the lubricating system checked by an authorized Dealer.

However, it is possible for the warning light to come on when the car is cornering: this may be caused by a low level of oil in the pan which can be easily remedied by topping up.

No trouble exists if the warning light comes on while the engine is idling, especially when hot.

Check that the low fuel pressure warning light on dashboard is off; when on, it means that the feed system is developing troubles; therefore, have it checked by your Dealer.

Do not drive at high speed until the oil in the engine, transmission and differential has warmed up properly.

When shifting gears, take care to depress the clutch pedal fully; this will ensure smooth operation and save synchronizers from excessive wear. Do not rest your foot on clutch pedal when not actually using it.

On decelerations, never depress the accelerator pedal or detonations will take place in the exhaust pipe.

IMPORTANT NOTE

The fuel injection system allows the engine to be used in the widest RPM range; however, in gears higher than the second, the best performance and emission control as well, can only be attained by exceeding 2200 RPM.

Never leave the key in the **MARCIA** position (ignition « on ») to prevent battery discharge and coil damage. Apply the hand brake and, when parking the car uphill or downhill, shift into a low gear and steer the front wheels in such a direction as to cause the car, should the parking brake disengage accidentally, to move toward the curb.

While parking

How to use your car

To keep a constant fuel/air ratio even when the room temperature varies as the seasons change, the temperature compensator lever, see figure, on the control unit shall be shifted to:

- mark **N** (normal) for room temperatures exceeding 59 °F.
- mark **C** (cold) for temperatures between 59 °F and 32 °F.
- mark **F** (freezing) for temperatures below 32 °F.

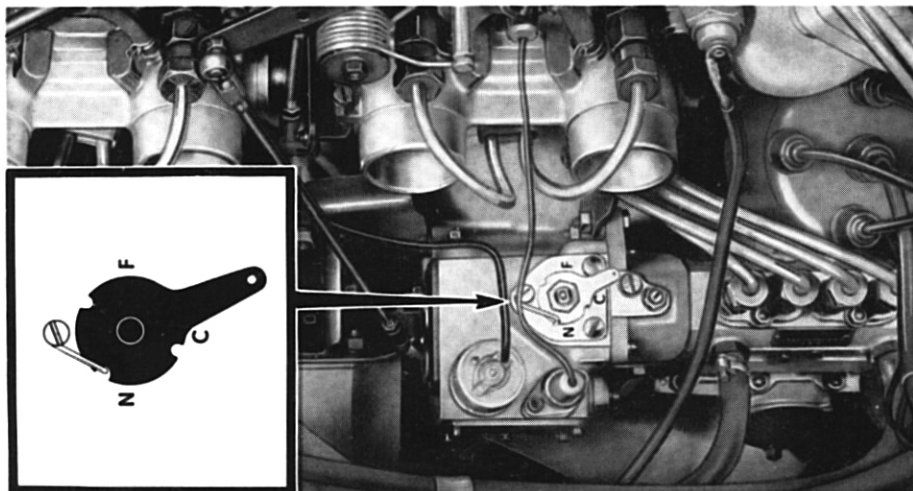

The **Alfa Romeo coolant mixture** gives full protection against freezing down to -5°F .

In places where the temperature falls below -5°F , the antifreeze mixture can be made stronger by varying its concentration.

To this end, a certain amount of mixture should be drained off the circuit and replaced with the same quantity of **Alfa Romeo antifreeze** drawn from suitable containers available by **Alfa Romeo Dealers**.

The quantities of antifreeze to be added to radiator and reservoir depending on the lowest anticipated temperature are the following:

Temperature	Amount of Alfa Romeo Coolant Mixture to be replaced with an equal quantity of Alfa Romeo Antifreeze .		
	Radiator	Reservoir	Total
-16°F	800 cc.	200 cc.	1000 cc.
-30°F	1600 cc.	400 cc.	2000 cc.
-48°F	2400 cc.	600 cc.	3000 cc.

It is recommended that this operation should be entrusted to an authorized Dealer.



- A** Air inlets in engine hood
- B** Air shutter
- C** Electric blower
- D-E** Water pipes
- F** Windshield demisting slits
- G** Air outlets into car
- H** Ram air ventilation

- 1** Blower switch
- 2** Blower operation warning light

- 3** Temperature control
 - 3a Warm air
 - 3b Warm & fresh air
 - 3c Fresh air

- 4** Air control
 - 4a Demisting
 - 4b Demisting ventilation heating
 - 4c Closed

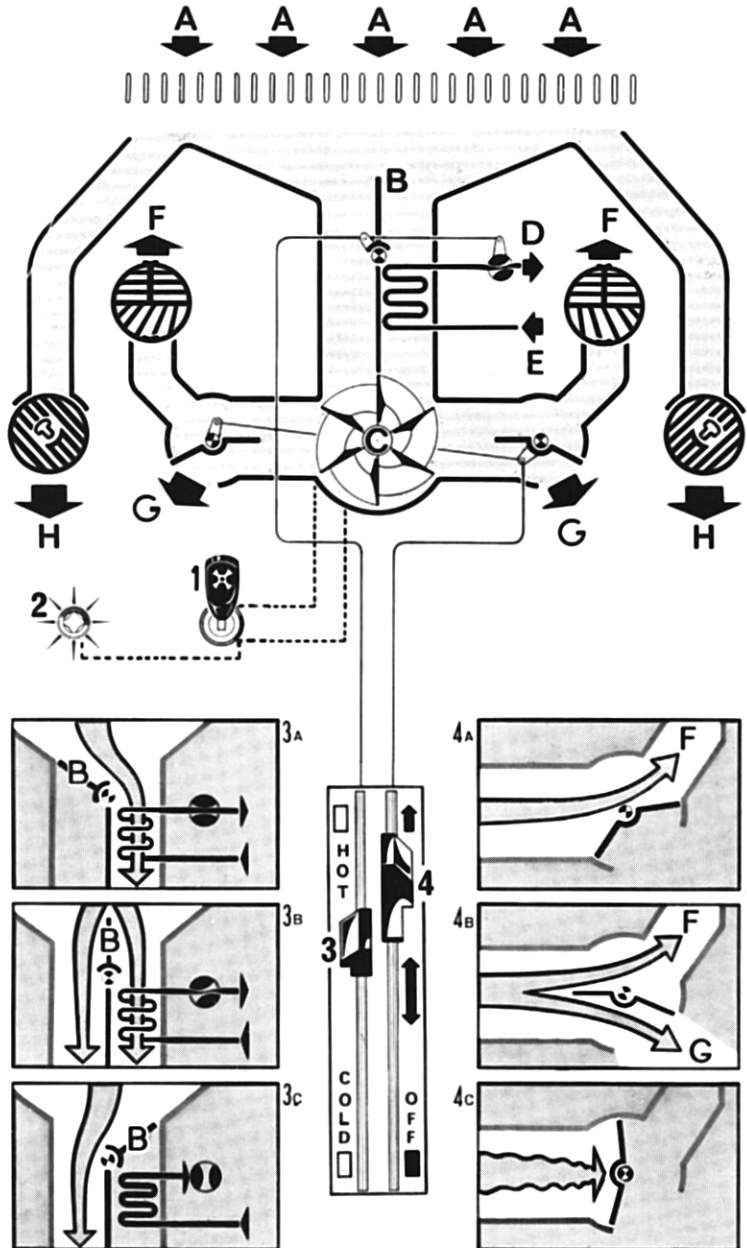

How to use your car

VENTILATION DEMISTING AND HEATING

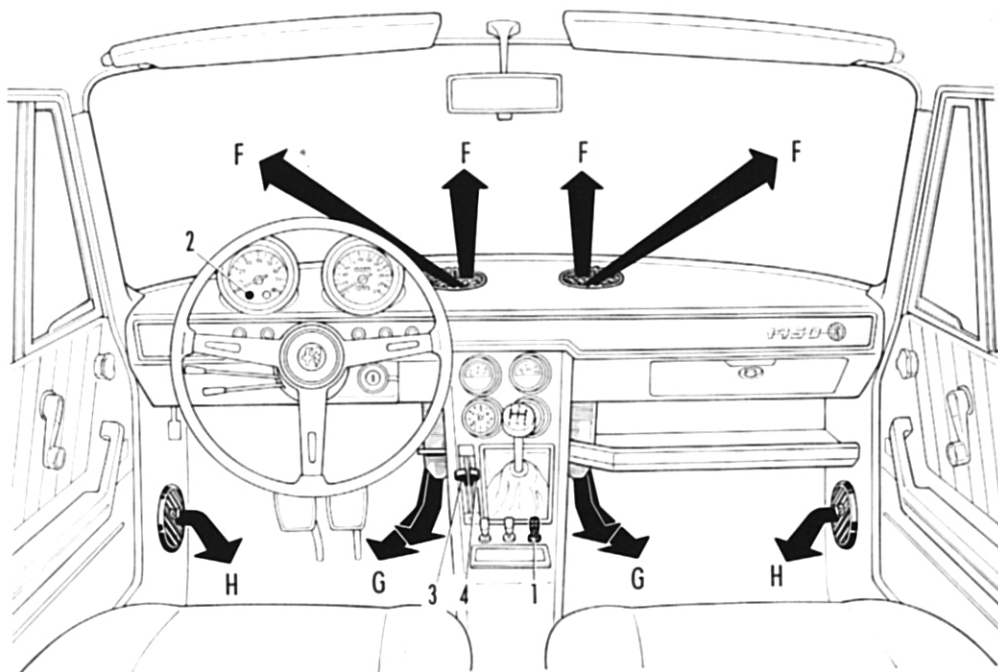

From **A** air enters thru:

- **F** for windshield demisting (warm and fresh air)
- **G** for ventilation and heating
- **H** for ventilation

Controls

- The air admitted to the car thru **B** can be gradually heated by the movement of the lever

3 which operates the shutter **B** and the cock **D**.

- The movement of the lever **4** gradually regulates the flow of air thru the openings **F** and **G**.
- In order to produce a satisfactory flow of air into the car at low speeds, switch on the two-speed electric blower by means of switch **1**. Warning light **2** indicates that this has been done.

Location of controls and air outlets

(refer to page 28)

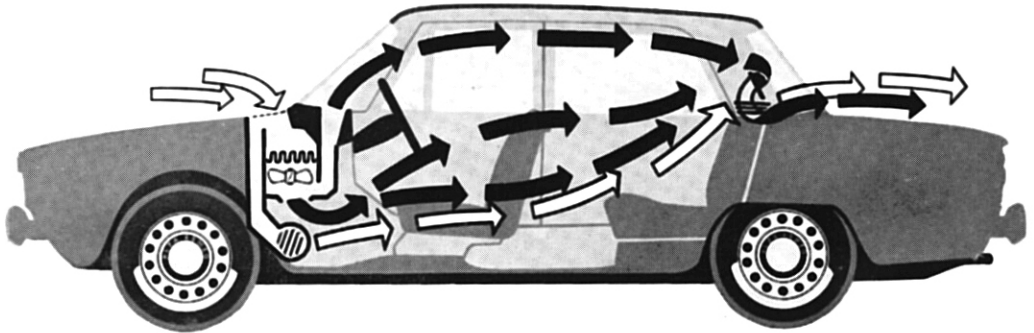

- ⇨ Fresh air
- ⇨ Fresh or warm air

For a best ventilation, flow away slits are provided at rear window posts.

**Ventilating
outlets**

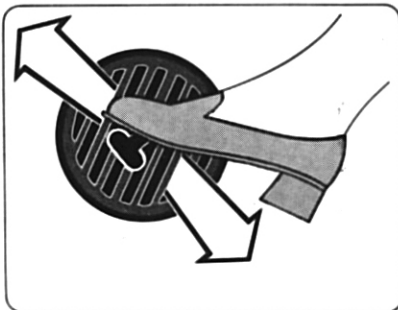

**LEVER DOWN
" OPEN "**

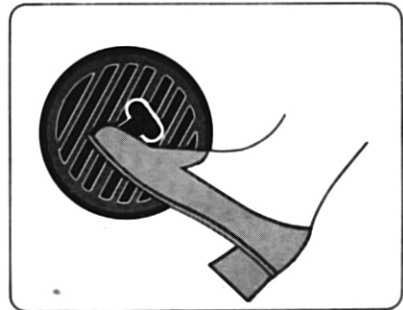

**LEVER UP
" CLOSED "**

How to use your car

VENTILATION DEMISTING AND HEATING

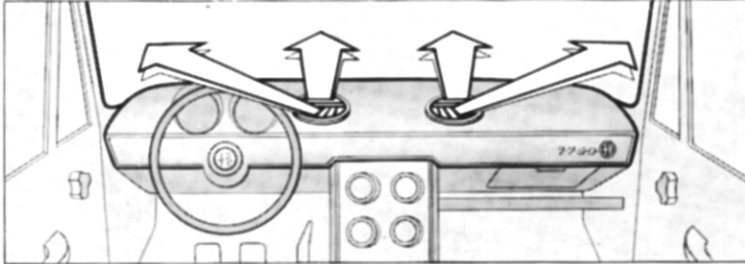

**Windshield
demisting**

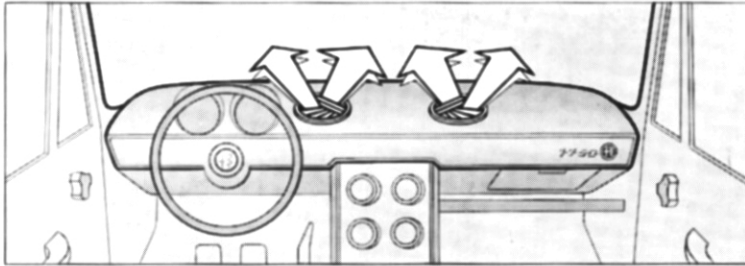

Spot demisting

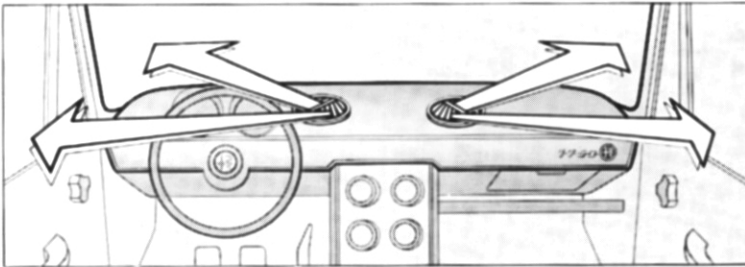

**Windshield and front
windows demisting**

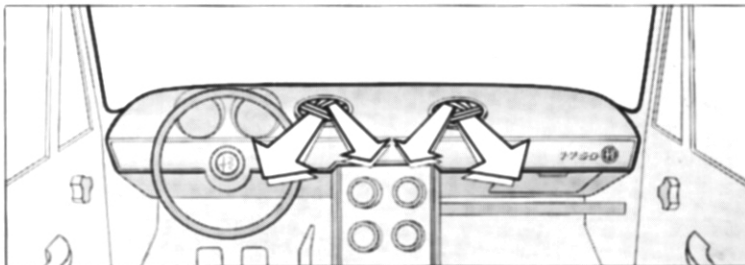

**Ventilating
or heating**

The illustrations show some examples of outlet positions.

The outlets can be rotated by hand as desired.



- A** Air inlets in engine hood
- B** Air shutter
- C** Electric blower
- D-E** Water pipes
- F** Windshield demisting slits
- G** Air outlets into car

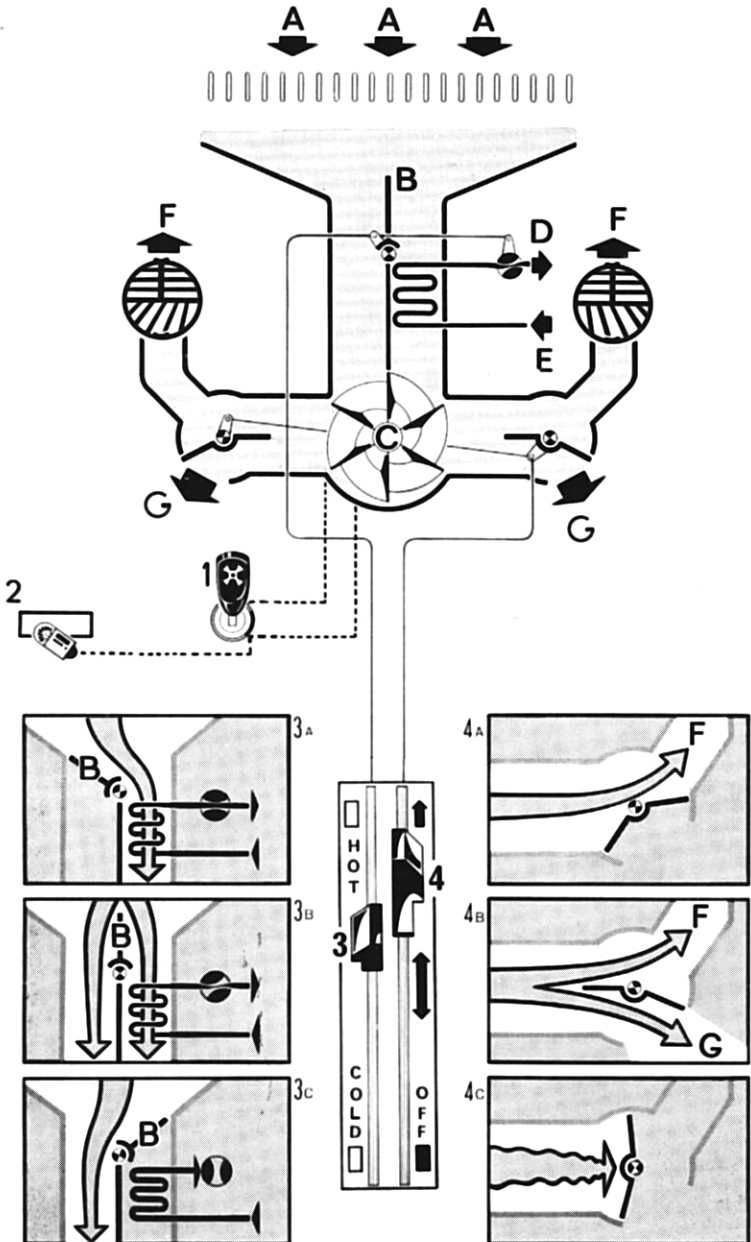

- 1** Blower switch
- 2** Blower operation warning light
- 3** Temperature control
 - 3a Warm air
 - 3b Warm & fresh air
 - 3c Fresh air
- 4** Air control
 - 4a Demisting
 - 4b Demisting ventilation heating
 - 4c Closed

How to use your car

VENTILATION DEMISTING AND HEATING

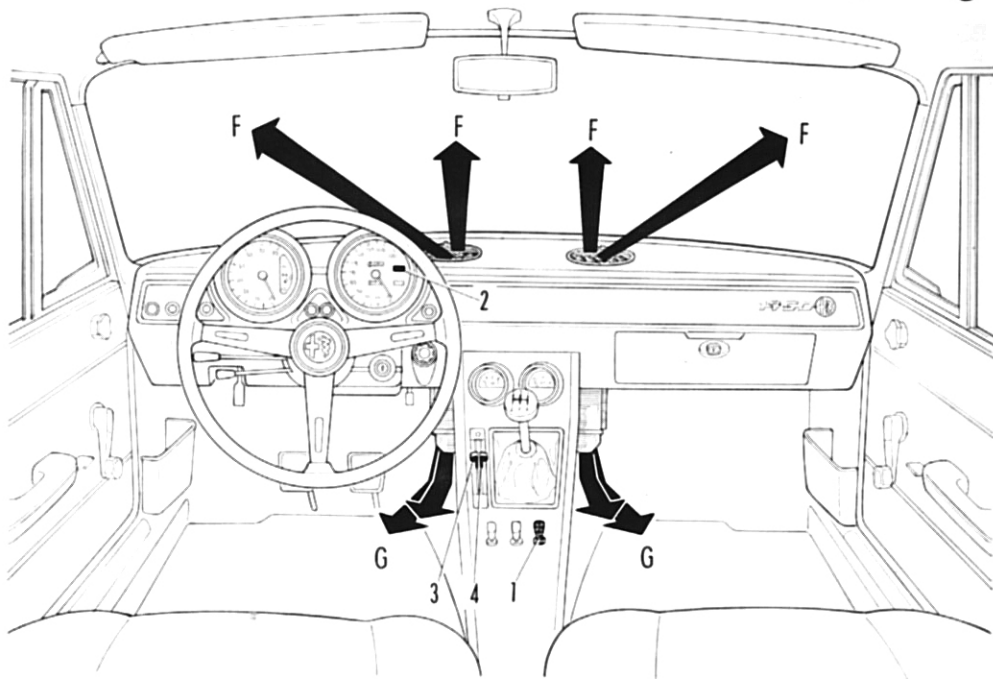

From **A** air enters thru:

- **F** for windshield demisting warm and fresh air)
- **G** for ventilation and heating

Controls

- The air admitted to the car thru **B** can be gradually heated by the movement of the lever

3 which operates the shutter **B** and the cock **D**.

- The movement of the lever **4** gradually regulates the flow of air thru the openings **F** and **G**.
- In order to produce a satisfactory flow of air into the car at low speeds, switch on the two-speed electric blower by means of switch **1**. Warning light **2** indicates that this has been done.

Location of controls and air outlets

(refer to page 32)



⇨ Fresh or warm air

◆ Fresh air

Opening the two quarter windows ensures proper ventilation of interior by enhancing the air flow away.

The opening of quarter windows can be regulated as desired by adjustable catches.

Quarter windows

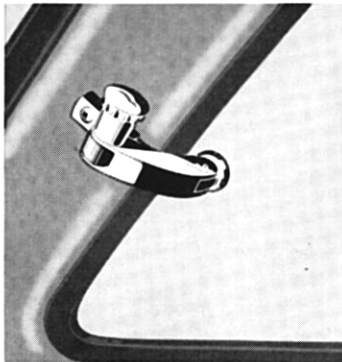

CLOSED

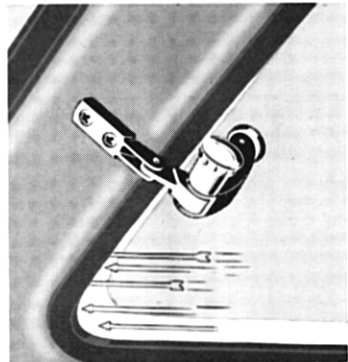

OPEN

How to use your car

VENTILATION DEMISTING AND HEATING

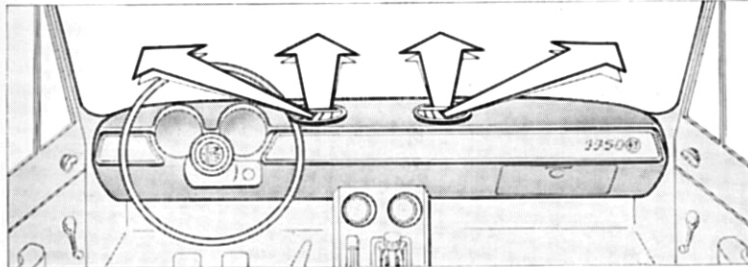

**Windshield
demisting**

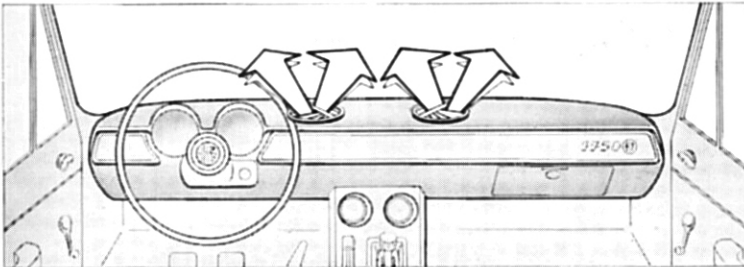

Spot demisting

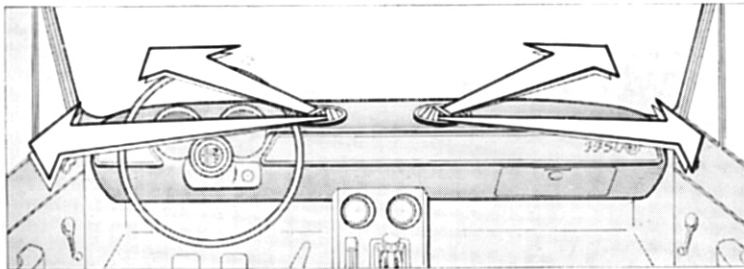

**Windshield and front
windows demisting**

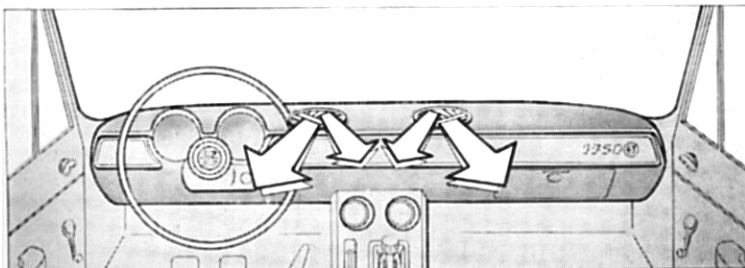

**Ventilating
or heating**

The illustrations show some examples of outlet positions.

The outlets can be rotated by hand as desired.



Diagram

- A** Air inlets in engine hood
- B** Air shutter
- C** Heater
- D** Electric blower
- E** Air outlet into car
- F** Windshield demisting slits
- G** Air control
- H** Temperature control
- LM** Water pipes & cock
- N** Blower switch
- P** Blower operation warning light
- R** Ventilating outlets (ram intake only)
- S** Ventilating outlet control

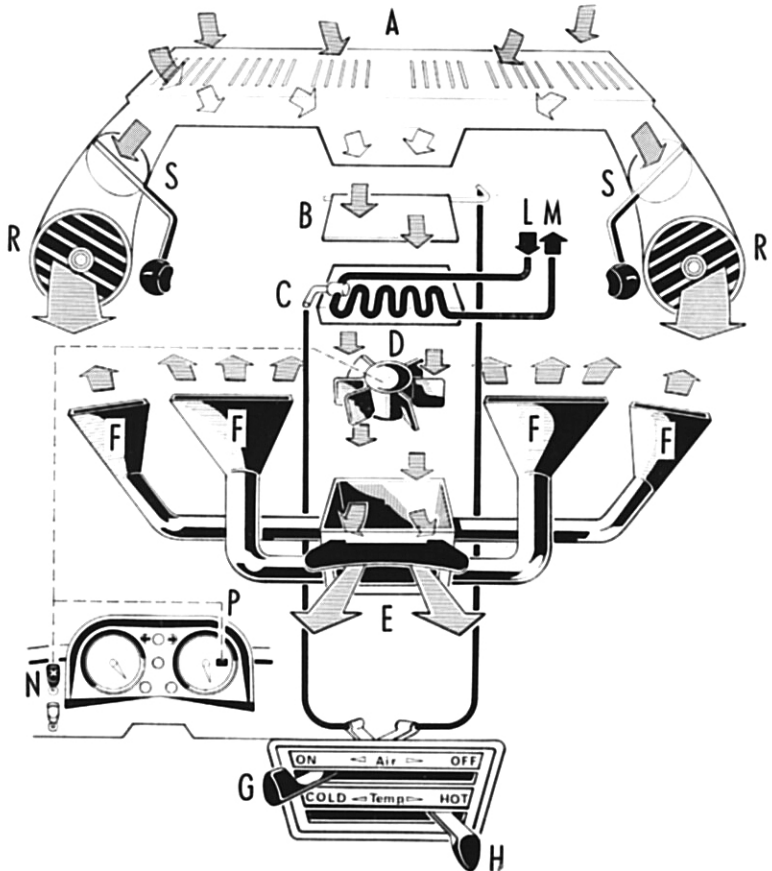

How to use your car

VENTILATION DEMISTING AND HEATING

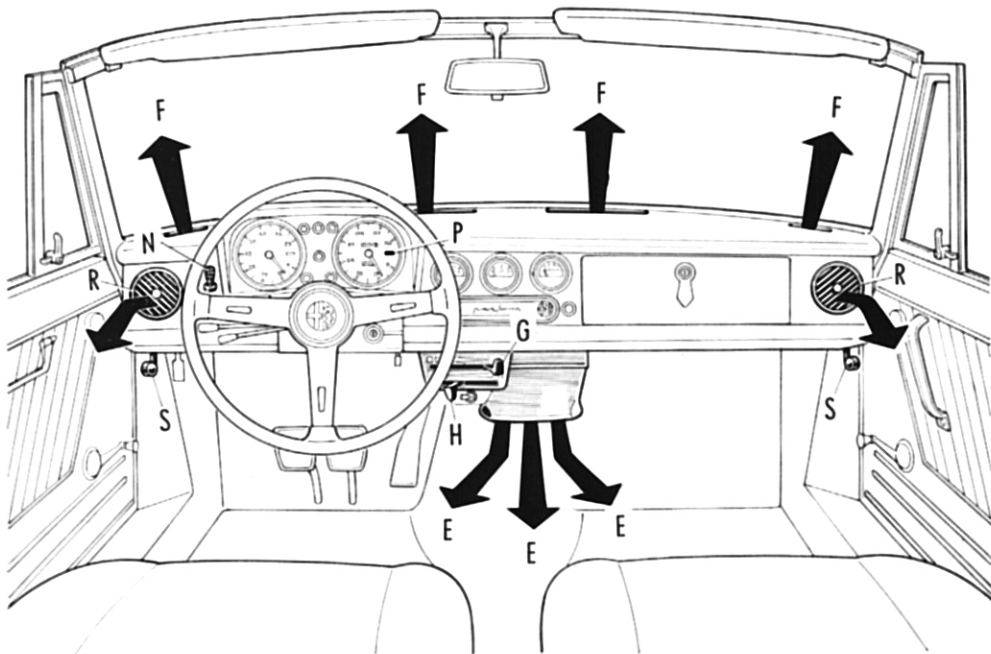

From **A** air enters thru:

- **F** for windshield demisting (warm and fresh air). For maximum defrosting switch on the blower and close the shutter.
- **E** for ventilation and heating
- **R** ram ventilation

Controls

- The air admitted to the car can be heated by the movement of

the lever **H** which operates the cock **LM**.

- The movement of the lever **G** gradually regulates the flow of air thru the openings **F** and **E**.
- In order to produce a satisfactory flow of air into the car at low speeds, switch on the two-speed electric blower by means of switch **N**. Warning light **P** indicates that this has been done.

**Location of controls
and air outlets**
(refer to page 36)

INTERIOR

How to use your car



Sun visors

- The front seats are equipped with padded sun visors which can be moved laterally.

Rearview mirror

- The rearview mirror has a day/night antiglare device.

Lighting

- Courtesy lighting is provided by two dome lights; the switches have three positions:
one in the center: lights always off
two at the sides: lights always on or automatically operated when opening doors.

Ash trays

- At the sides of the rear seats are two ash trays. They can be removed for emptying by pressing down the small central spring inside the ash tray.





- The positioning of the front seats is controlled by the lever **1** situated on the front edge of each seat: by freeing the lever the seat may be moved to the position desired.
The knobs **2** at the outboard sides of the seats control the angle of the backrests.
The seats are provided with vertically-adjustable headrests **3**.

Front seats



- An arm rest with utility recess is provided between rear seats.
For additional room, the arm rest can be removed and replaced with the padded cushion found in the trunk.

Rear seats

INTERIOR



How to use your car

Radio

Provision is made in the dashboard for the installation of the radio.

The location is:

- in the dashboard for the radio set
- in the console and on backshelf for the speakers.

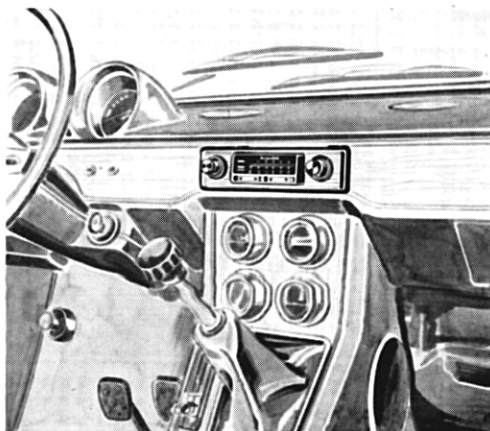

TRUNK

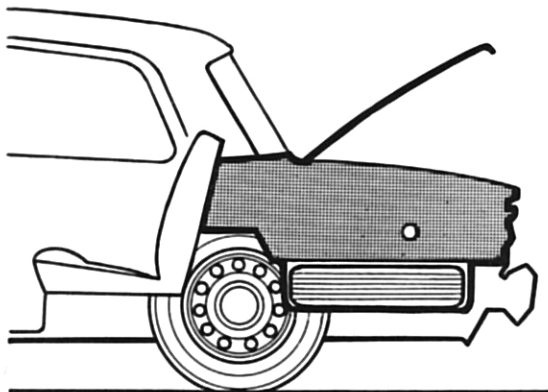

To open the trunk lid, only rotate the key in the lid lock.

The illumination of the trunk is effected by a light that operates automatically when the lid is raised and the parking lights are on.



The hood opens opposite travel direction; to release the catch, pull the lever under the dashboard. The hood is held in open position by the suitable rod. **1**. The illumination of the engine compartment is effected by a light fixed under the hood. It operates automatically when the hood is raised and the parking lights are on.

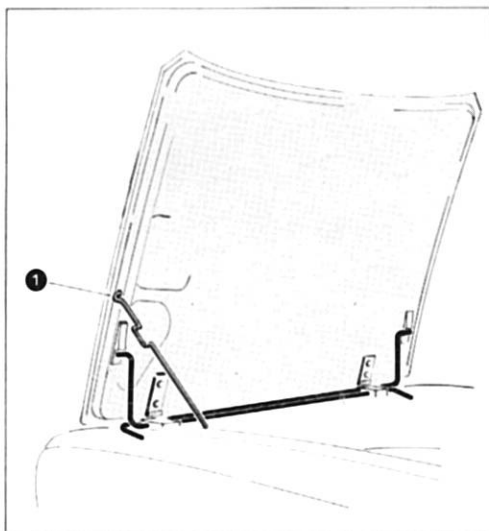

EMERGENCY RELEASE

To release the hood in an emergency, pull the ring shown by the arrow.

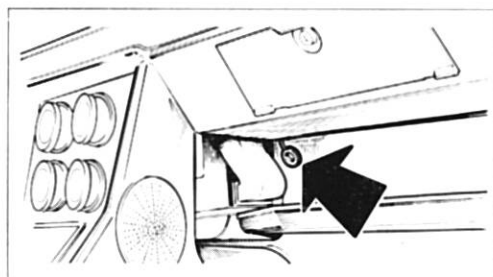



Front door

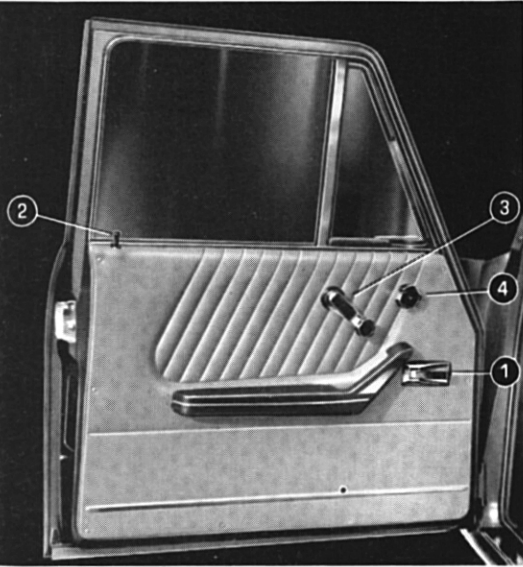

- 1 Handle for opening the door from inside.
- 2 Safety lock button: for locking the door from inside, push the button in after the door is shut. On rear doors the safety button can be pushed in for pre-locking even if the door is open. Both front doors have locks for closing from the outside.

3 Window regulator handle.

4 Vent window control.

5 Ash tray; it can be removed for emptying by pressing down the small central spring inside the ash tray.

Rear door

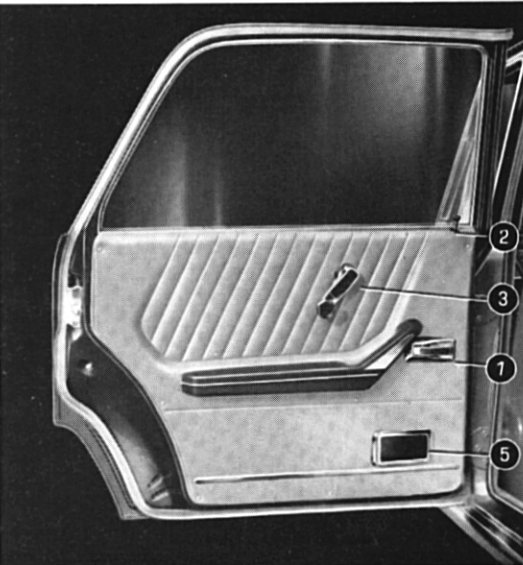



The cars are equipped with safety belts of lap and lap-shoulder type as shown below.

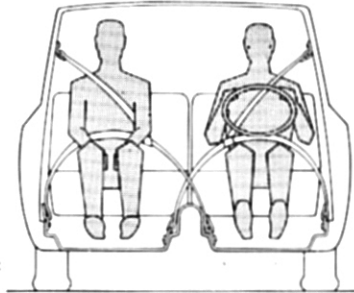

BERLINA FRONT SEATS and GT VELOCE:
LAP-SHOULDER

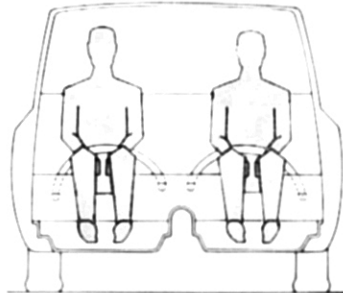

BERLINA REAR SEATS: LAP

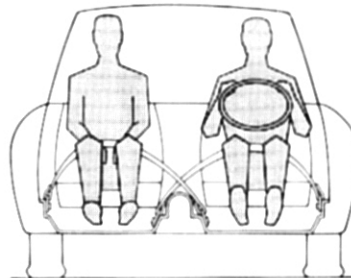

SPIDER VELOCE: LAP



Note: on Berlina and GT Veloce rear lap-shoulder harness can be installed optionally.

Attachment provision:

- for BERLINA the third attachment is on the rear shelf;
- for GT VELOCE the three attachments are on the sheet metal behind the bench seat backrest and on the panel of wheelhouse and rear shelf.



How to use your car

Sun visors

- The front seats are equipped with padded sun visors which can be moved laterally.

Rearview mirror

- The rearview mirror has a day/night antiglare device.

Lighting

- Courtesy lighting is provided by two dome lights; the switches have three positions:
one in the center: lights always off
two at the sides: lights always on or automatically operated when opening doors.

Ash trays

- At the sides of the rear seats are two ash trays. They can be removed for emptying by pressing down the small central spring inside the ash tray.





- The positioning of the front seats is controlled by the lever **1** situated on the front edge of each seat: by freeing the lever the seat may be moved to the position desired.

The knobs **2** at the inboard sides of the seats control the angle of the backrests. The levers **3** at the outboard sides of the seats allow to unlock the backrests for tipping forward.

The bucket type seats are provided with vertically-adjustable headrests **4**.

Seats





Radio

Provision is made in the dashboard for the installation of the radio.

The location is:

- in the dashboard for the radio set
- in the console for the speakers.

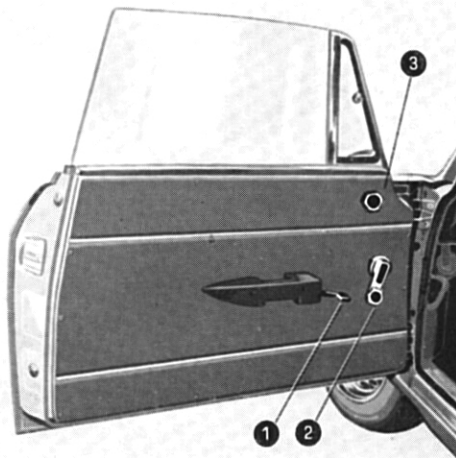

DOORS

- 1 Lever to actuate and release the safety device (both doors). Both doors have locks for closing from the outside. To close, turn the key in the direction of travel (the key can be withdrawn only when it is vertical).
- 2 Window regulator handle.
- 3 Vent window control.



The hood opens opposite travel direction; to release the catch, pull the lever under the dashboard (see 26 page 17). The hood is held in open position by the suitable rod 1.

The illumination of the engine compartment is effected by a light fixed under the hood. It operates automatically when the hood is raised and the parking lights are on.

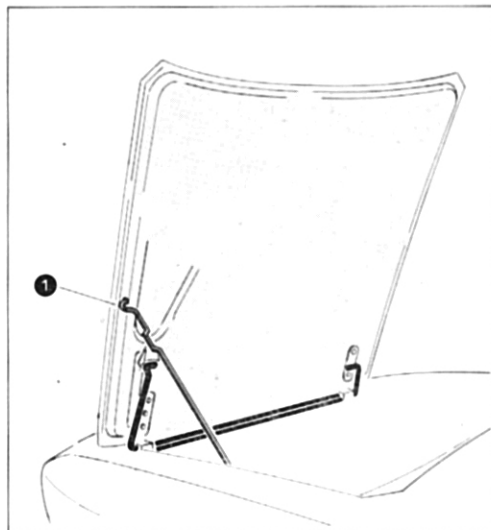

To open, lift the lever situated on the door jamb on the passenger's side. The lock utilises the same key as the doors.

TRUNK

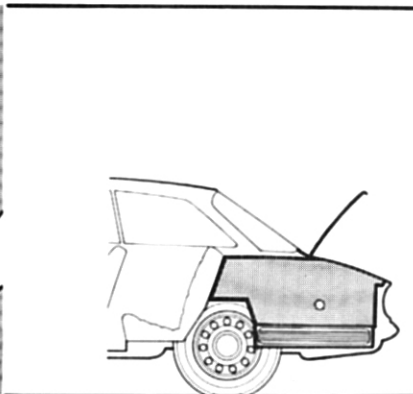
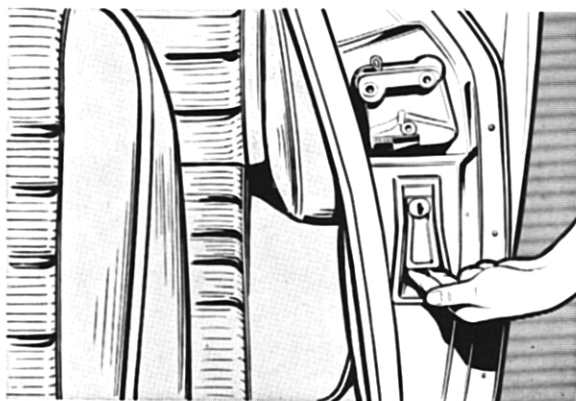

INTERIOR



How to use your car

- Suns visors** ● The car is equipped with padded sun visors.
- Rearview mirror** ● The rearview mirror has a day/night antiglare device.
- Lighting** ● Internal lighting is provided by a lamp in the rearview mirror; the switch has two positions: light always on and courtesy light automatically operated when opening doors.
- Hand grip** ● On the passenger's door there is a hand grip.

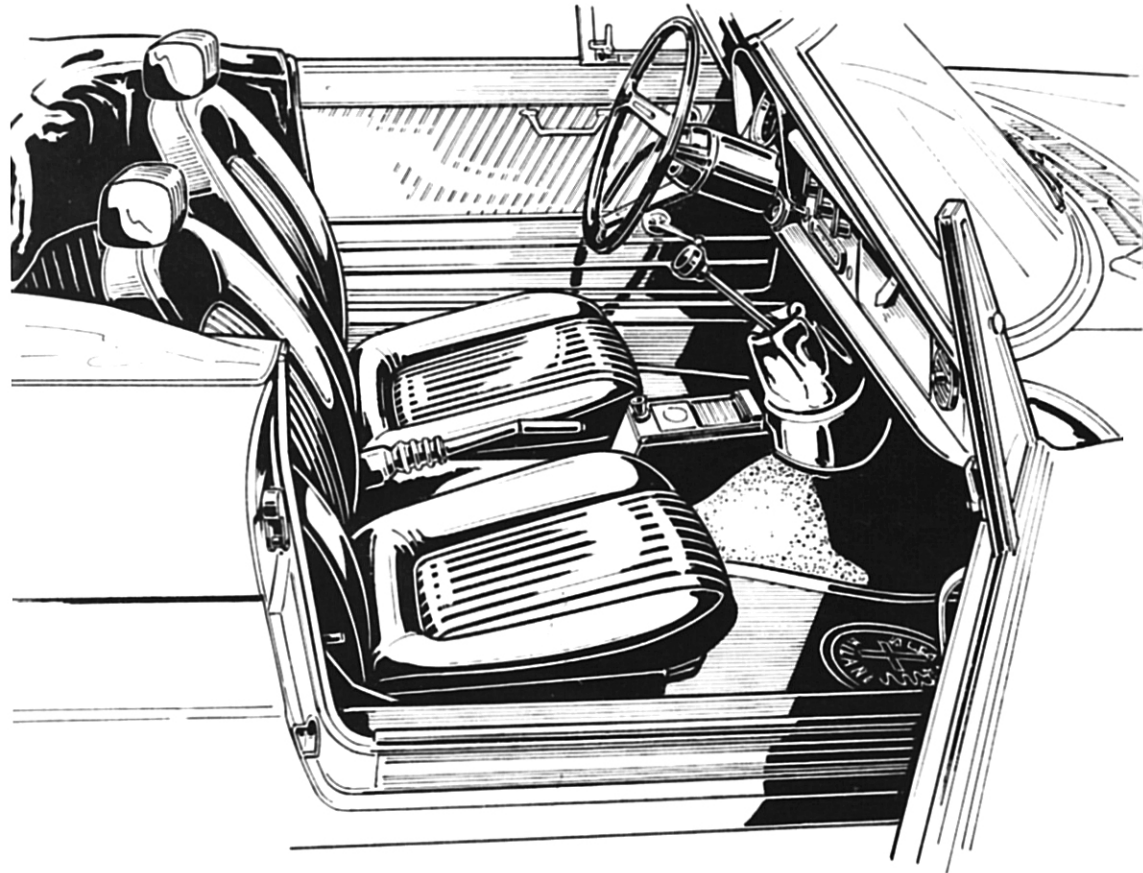

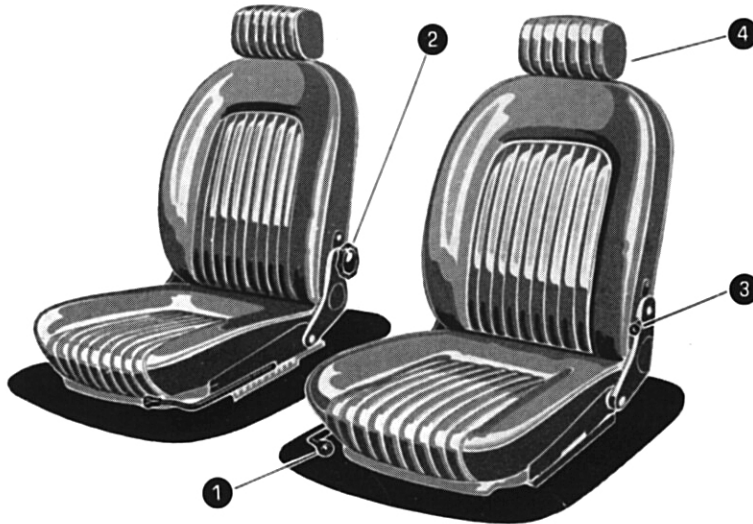

Seats

- The positioning of the seats is controlled by the lever 1 situated on the front edge of each seat: by freeing the lever the seat may be moved to the position desired.
- The knobs 2 at the inboard sides of the seats control the angle of the backrests. The levers 3 at the outboard sides of the seats allow to unlock the backrests for tipping forward.

The bucket seats are provided with vertically-adjustable headrests 4.

HARD TOP

Provision is made for the installation of the hard top. Attachment is effected thru the hooks suitably provided on the body.

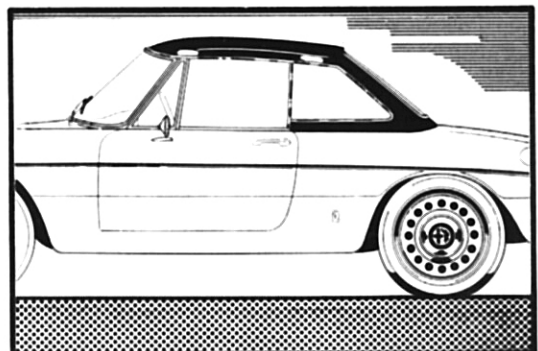



Radio

Provision is made in the dashboard for the installation of the radio. To install it, remove the ornament from dashboard (see 22 on page 19).

DOORS

- 1 Handle
- 2 Vent window control (with a safety catch)
- 3 Lever to actuate and release the safety device. Both doors can be locked from the outside.
- 4 Window regulator handle

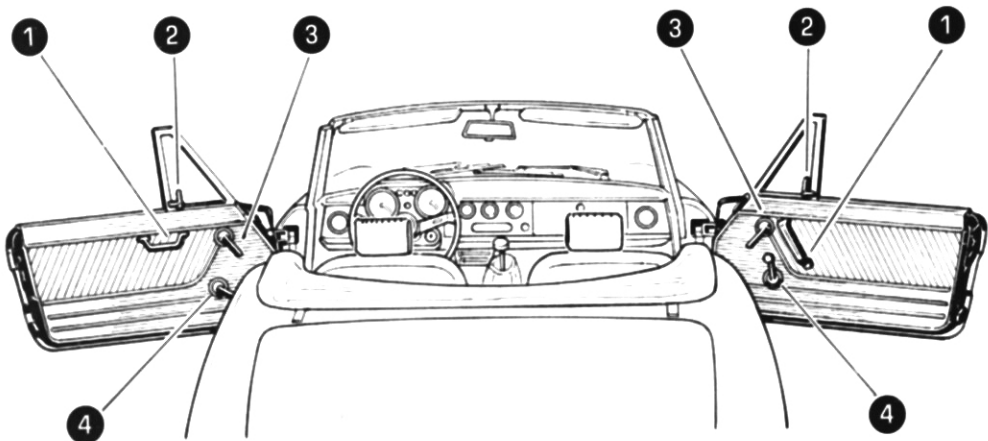



The hood opens opposite travel direction; to release the catch, pull the lever under the dashboard (see 29 on page 19).

The illumination of the engine compartment is effected by a light fixed under the hood. It operates automatically when the hood is raised and the parking lights are on.

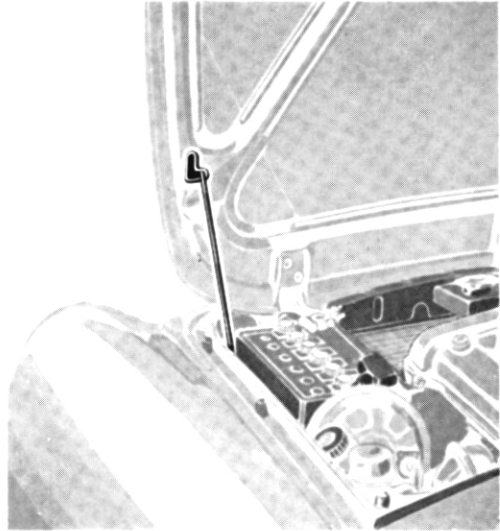

To open, lift the lever situated on the door jamb on the passenger's side. The lock utilises the same key as the doors.

TRUNK

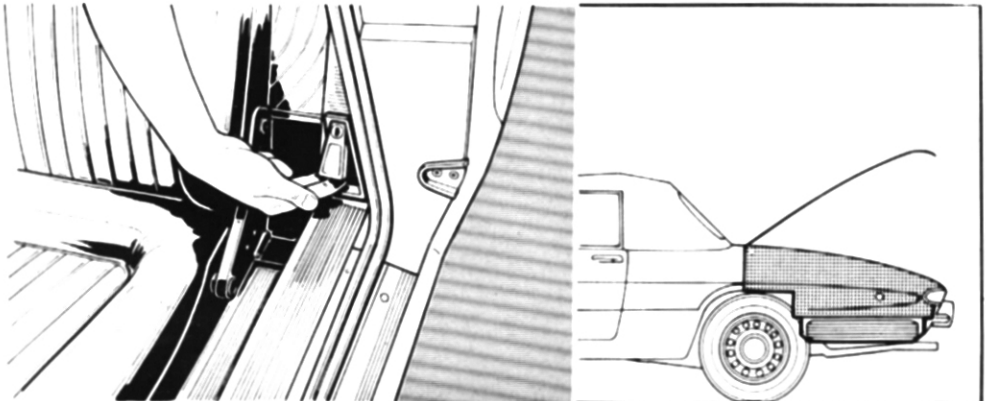



How to use your car

Folding the top

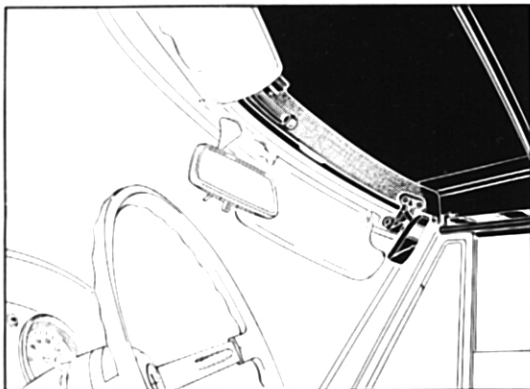

Lower the side windows.
Release the toggle clamps securing the top to the windshield bow.

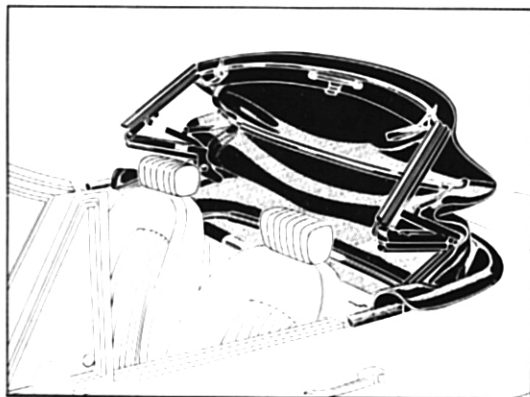

Push the top frame backward.

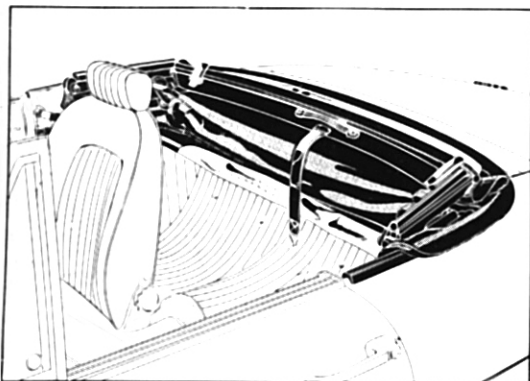

Fold the top into its housing taking care not to crumple the plastic window. When folded, fasten the top with the proper self-sticking strap.

How to use your car



Take the top cover out of the trunk and connect the two bows with the bayonet joint 1.

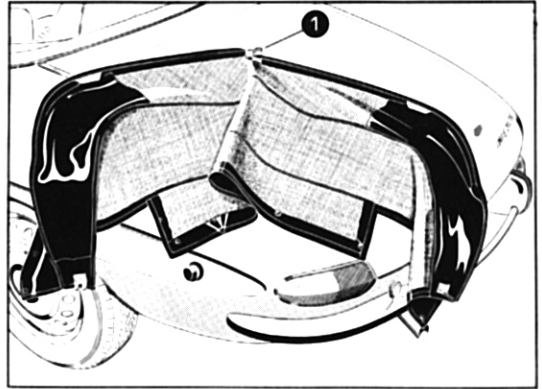

Spread the cover onto the top and engage the bows in the hooks on the body.

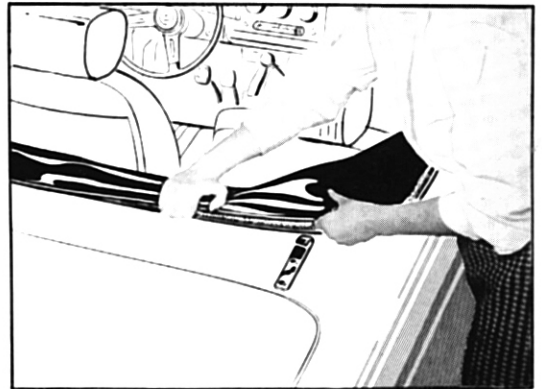

Insert the forks 1 into their seats in the door jambs. Finally, secure the cover to the inside of the car with the fasteners.

Note: to raise the top reverse the folding procedure.





How to use your car

WHEELS

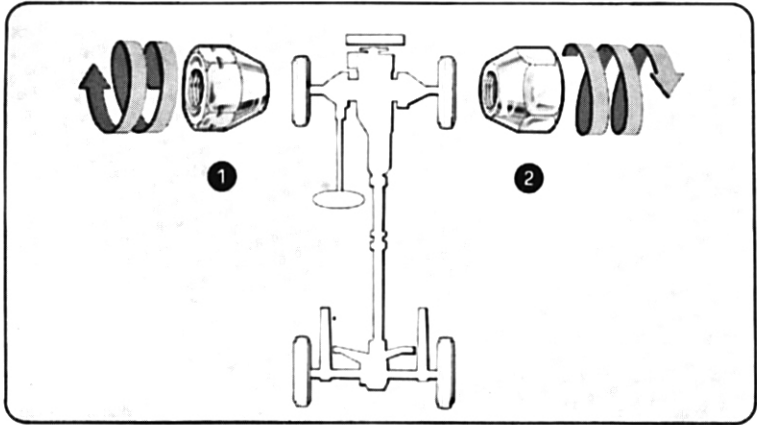

The dimensions of the pressed steel wheels are:

5 1/2 J x 14

Wheel removal



- Remove wheel cover and slacken wheel nuts by one turn with the wheel wrench.
 - 1 left-hand wheels: turn the nuts **clockwise** to unscrew
 - 2 right-hand wheels: turn the nuts **counterclockwise** to unscrew.
- Raise the car by inserting the jack arm in the special socket in the body rocker panel.
Before operating the jack, apply the parking brake.

Reinstallation

- Fully unscrew the nuts and remove the wheel.
- Tighten the nuts carefully in diagonal order. Check again tightness of nuts after lowering the jack.
 - left-hand wheels: turn the nuts **counterclockwise** to screw in
 - right-hand wheels: turn the nuts **clockwise** to screw in.

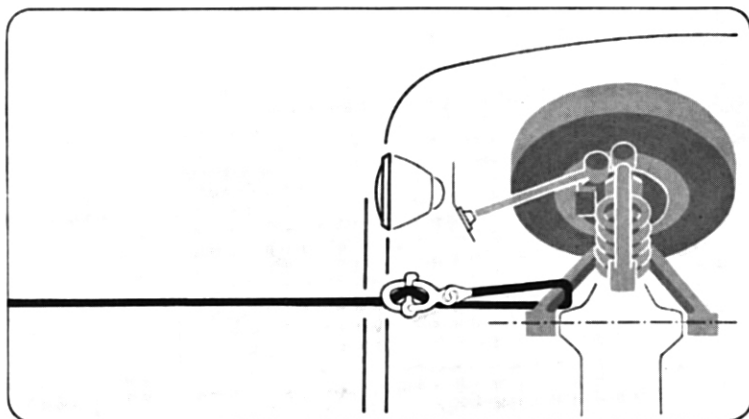

When taking a tow, secure the rope exclusively to the front suspension lower arm in correspondence of the attachment to body.

Take A tow

When taking another vehicle in tow, secure the rope to the axle tube making certain not to damage the pipes of hydraulic brakes.

Take IN tow

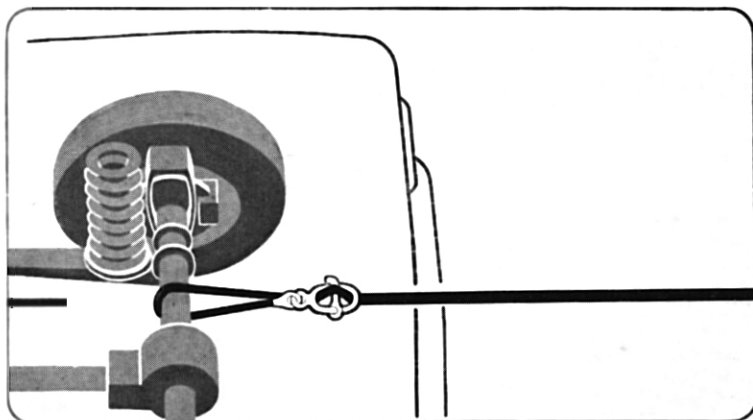

LUBRICATION

Routine lubrication after Coupons A and B:

- EVERY 300 mi.**
- 1** Check level of engine oil and top up if necessary.
When checking push the dipstick all the way down. Never allow the oil to fall below the minimum or to exceed the maximum level while topping up.
- EVERY 3,000 mi.**
- 2** Check level of transmission oil and top up if necessary.
- 3** Check level of differential oil and top up if necessary.
- 4** Check level of steering box oil and top up if necessary.
- EVERY 12,000 mi.**
- 5** Change engine oil (or every 6 months whichever comes first).
- 6** Change oil filter element.
- 7** Grease ignition distributor.
- 8** Grease drive shaft U-joints & slip yoke.
- OCCASIONALLY**
- 9** Change transmission oil.
- 10** Change differential oil.
- Grease the linkage joints or hinges of:
- throttles
 - clutch & service brake
 - parking brake
 - doors & lids
- Grease flexible shafts & cables

X									

6,000 9,000 12,000 15,000 18,000 21,000 24,000 27,000 30,000

MILEAGE COVERED
TICK EACH ITEM AT THE RESPECTIVE MILEAGE

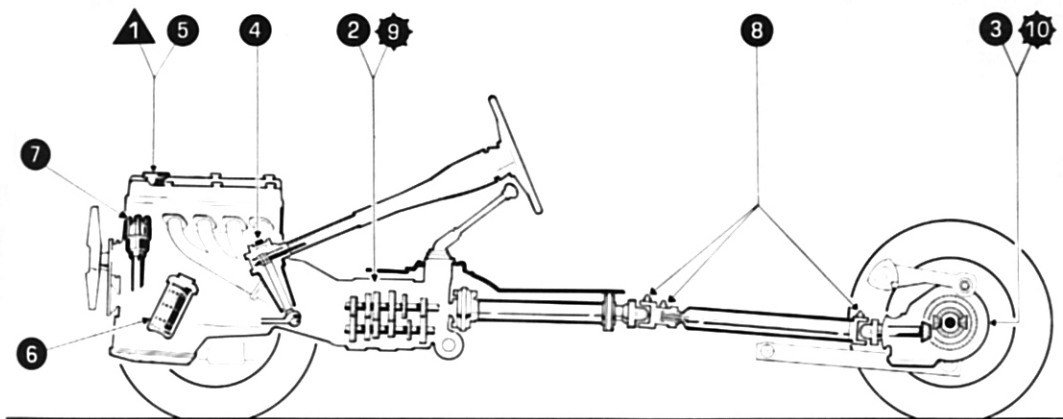

RECOMMENDED LUBRICANTS

PART	Classification	Commercial equivalents		
		AGIP	Shell	Esso
Engine	SAE 20 W/40 API MS	AGIP F.1 Supermotoroil Multigrade 20 W/40	SHELL Super Motor Oil 10 W/30	UNIFLO Motor Oil 10 W - 20 W - 40
Transmission Steering box and differential	SAE 90 API EP	AGIP F.1 Rotra Hypoid SAE 90	SHELL Spirax 90 EP	
Drive shaft universal joints and slip yoke	NLGI 1	AGIP F.1 Grease 15	SHELL Retinax G	
Front wheel bearings (see maintenance schedule)	NLGI 2/3	AGIP F.1 Grease 33 FD	SHELL Retinax AX	

API - American Petroleum Institute
NLGI - National Lubricating Grease Institute
SAE - Society of Automotive Engineers

The engine is pressure lubricated by a gear pump mounted on the front cover of crankcase and driven by a shaft thru a pinion keyed to the crankshaft front end.

The oil pressure is adjusted by a relief valve.

Oil level

When checking push the dipstick all the way down. Never allow the oil to fall below the minimum or, while topping up, to exceed the maximum level.

It is recommended to top up with the same type of oil as that in the engine.

**Oil change
(engine
warmed up)**

With the engine stopped, drain off old oil thoroughly.

Remove the filter body and clean the inside of it.

Replace the filter element.

Replenish with new oil.

**Oil replacement
after engine
reconditioning**

With a reconditioned engine follow the instructions given for the **breaking in period**.

The oil pressure is controlled by a relief valve in the pump body. **If the pressure falls below the minimum values**, an Alfa Romeo Dealer must be consulted to trace and remedy the fault. Lubricating circuit faults are indicated by a red warning light, too.

Maintenance

Oil pressures with hot engine - psi	
Engine running fast	minimum 50 maximum 65-70
Engine idling	minimum 7-14

Maintenance

To remove impurities the engine oil is filtered by a full-flow filter in series with the delivery circuit. The filter is fitted with a valve that bypasses the element if it should become clogged.

When replacing the filter element thoroughly clean the case.

It should be remembered that the periodical replacement of the element, perfect cleaning and careful assembly of the filter are essential for best engine performance.

On reassembling the filter, always replace the seal with a new one.

After refitting the filter to the engine, make sure that there are no oil leaks.

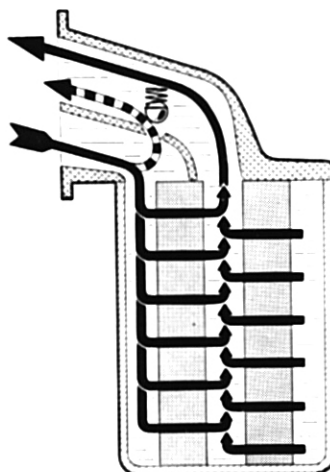

—
Oil flow with normal operation

- - -
Oil flow in an emergency

OIL FILTER

THOUSAND MILES Routine servicing after coupons A and B

3	1	BATTERY	Check electrolyte level.
	2	BRAKE PADS	Check for wear
	3	CLUTCH & BRAKE RESERVOIR	Check level of fluid
6	4	FAN & ALTERNATOR DRIVE BELT	Check tension
	5	VALVE TIMING CHAIN	Check tension
	6	AIR CLEANER ELEMENTS	Cleaning
12	7	AIR CLEANER ELEMENTS	Change
	8	MAIN FUEL FILTER ELEMENT	Change
	9	CLUTCH PEDAL	Check free travel
15	10	SPARK PLUGS	Inspect and change as necessary
	11	DISTRIBUTOR & TIMING	Inspect and check
	12	VALVES	Check clearance and adjust as necessary
18	13	TANK FUEL FILTER	Change
	14	THROTTLES & INJECTION PUMP LINKAGE	Check positioning
	15	THROTTLES	Cleaning of throats and alignment
24	—	IDLE SPEED	Check
	—	ENGINE COOLING SYSTEM & AIR HEATER	Inspect hoses and replace as necessary
	16	BRAKE SYSTEMS	Change fluid (or once a year whichever comes first)
30	17	STEERING LINKAGE	Check for play
	—	CAR	Road and driveability test
	18	FRONT WHEELS	Adjust toe-in and check caster
30	19	ENGINE COOLING SYSTEM	Change coolant (or once a year whichever comes first)
	—	BRAKE SYSTEMS	Check thoroughly
	—	BOLTS AND NUTS	Tighten generally
	20	FRONT WHEEL BEARINGS	Adjust clearance & repack with grease

EVERY 300 miles: check tire pressures

OCCASIONALLY

Check level of coolant in engine cooling system reservoir.

6,000 9,000 12,000 15,000 18,000 21,000 24,000 27,000 30,000

MILEAGE COVERED

TICK EACH ITEM AT THE RESPECTIVE MILEAGE

MAINTENANCE

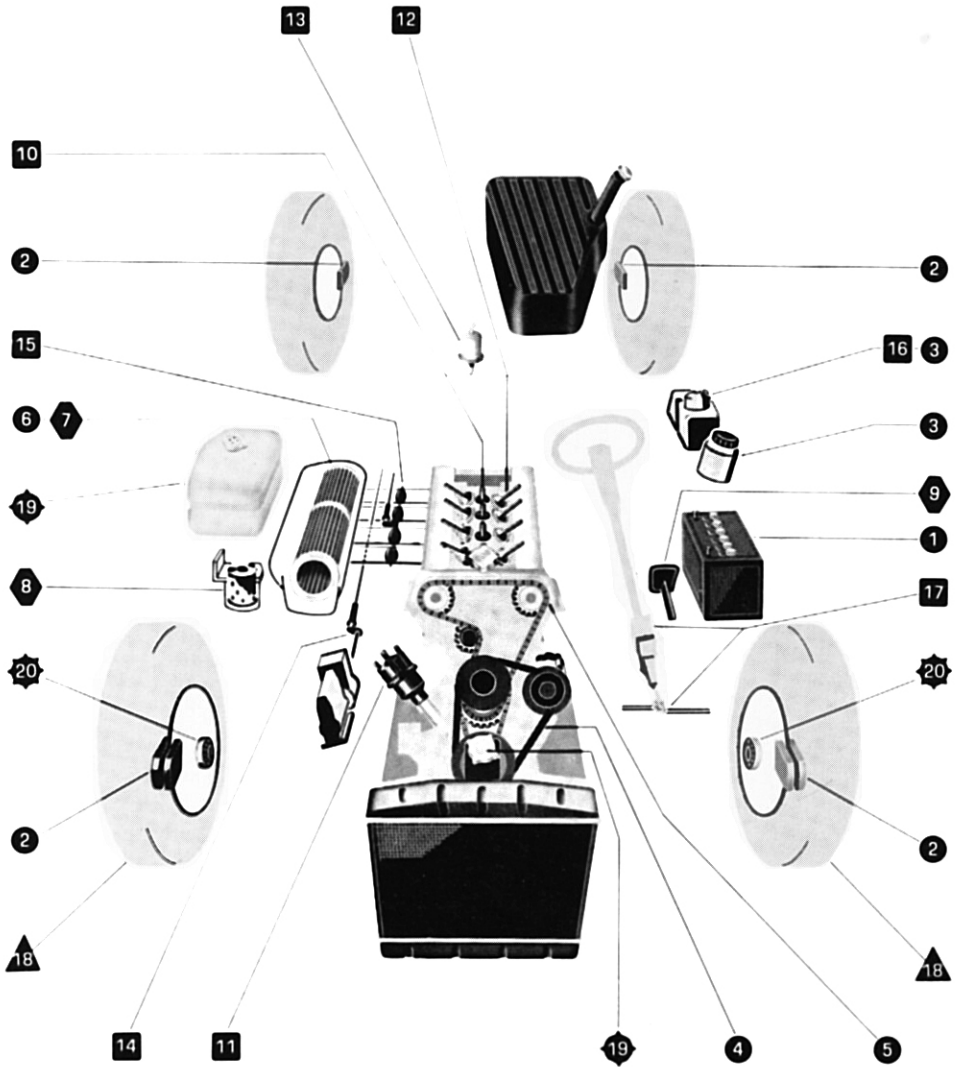

Tightening torque specifications

To avoid stressing the metal, tighten as follows **with a torque wrench set to the prescribed torque.**

Main bearing caps: lubetorque to
 Connecting rod bearing caps:
 lubetorque to
 Camshaft journal caps: lubetorque to

lb-ft
34-36
36-38
15-16

Cylinder head nuts

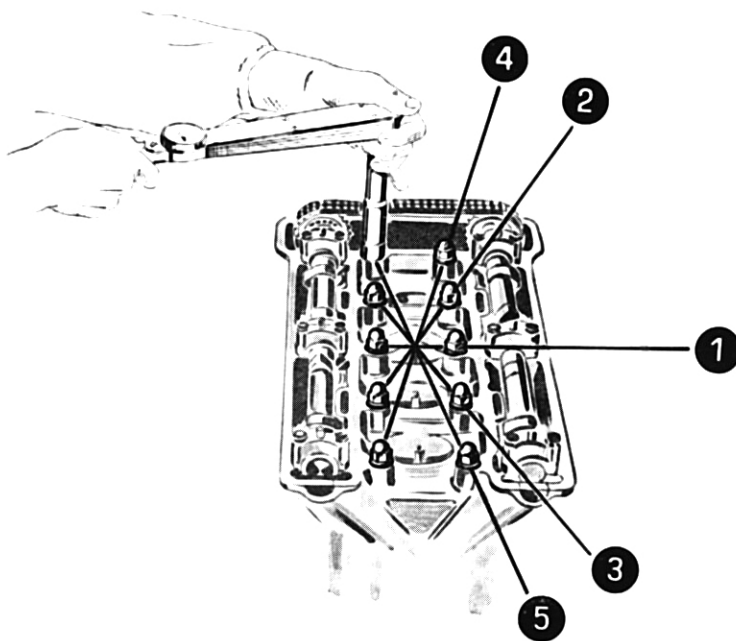

Tightening sequence

Tightening torque specifications

After reconditioning:
 lubetorque when cold to
 Then warm up the engine by actually driving the car and when hot **retighten without unscrewing** to
 After tested the car, slacken, **when cold**, when cold and in proper sequence, the nuts **by one and one half turn and lubetorque to**

lb-ft
52.1-53.5
55-55.7
52.1-53.5

The V-mounted overhead valves are directly operated by two camshafts acting thru oil bath cups.

When the engine is cold, carefully measure the clearance **G** with a feeler gage. If the clearance is not as specified, remove camshafts and valve cups; measure the thickness **S** of the adjusting pad on each valve stem and replace it with another of proper thickness so that the clearance is the correct one shown in the diagram.

Valve clearance adjustment

To facilitate this adjustment the pads are made available in a series of thicknesses ranging from **.051** to **.138** in. in increments of **.001** in.

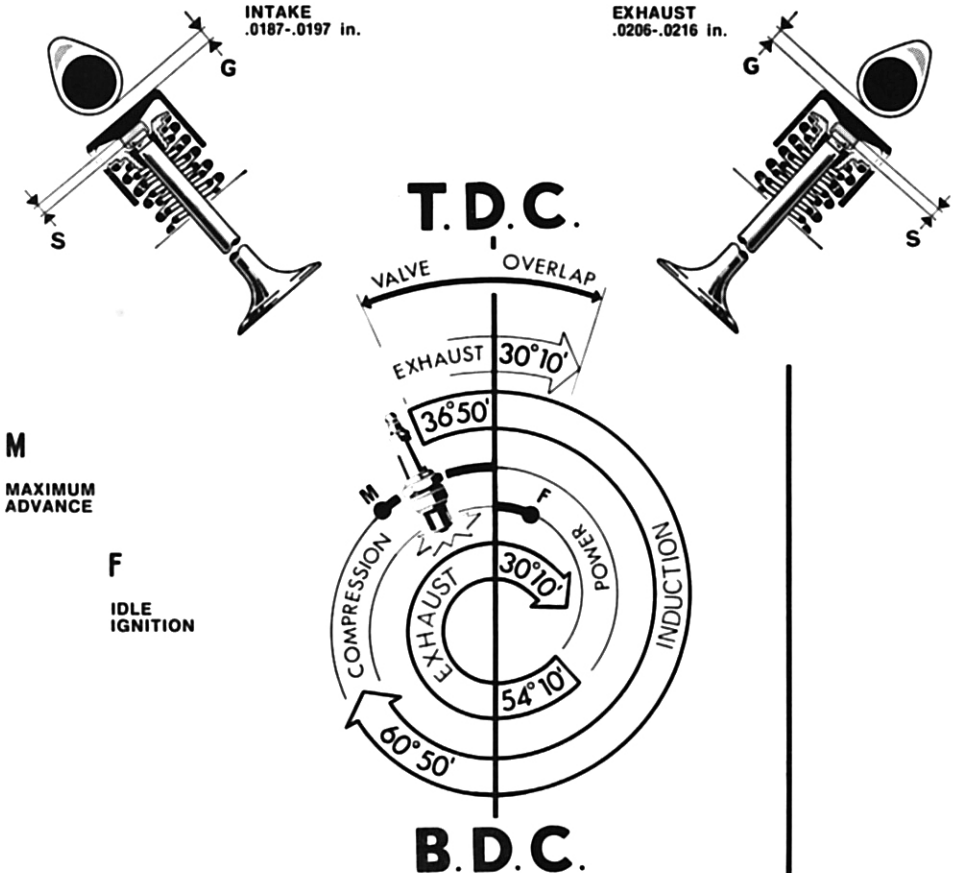

Checking and
timing

Top dead center

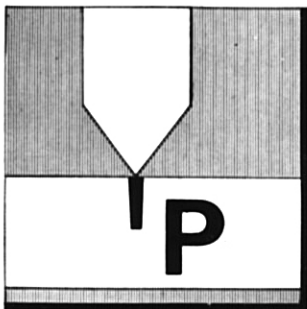

The valve timing is correct when:

- no. 1 piston on compression stroke, the timing mark cut in the crankshaft pulley and marked **P**, is in line with the reference plate and...

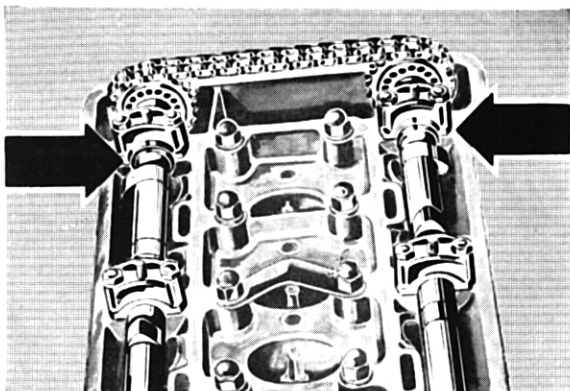

- ... when the timing marks cut on the camshaft front journals are in line with those on the journal bearings.

No. 1 cylinder cams must be positioned as shown in the illustration, i.e. **POINTING OUTWARD**.

Chain tension
adjustment

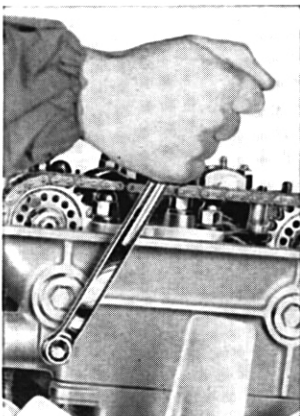

Proceed as follows:

- slacken off the setscrew securing the chain tensioner;
- run engine at idling speed to allow the tensioner to tighten the chain;
- lock the chain tensioner set-screw firmly.

Fuel is supplied to the engine by injection into the intake port of each cylinder in quantities exactly metered in accordance with the opening of throttles and RPM range.

The metering device, or « control unit », consists mainly of a barrel-shaped cam which slides automatically lengthwise as the RPM varies and rotates about its axis exactly timed with the opening of throttles.

The lift of a follower, moving closely against the cam contour, controls the delivery of the injection pump, without any lag in respect to the demand of power.

On deceleration, the fuel delivery is automatically cut off thus permitting not only to eliminate the unburned gases in a condition remarkably critical for the exhaust emission levels, but also to affect favorably the fuel consumption.

The control unit also includes suitable compensating devices which gives proper corrections for atmospheric pressure, engine and room temperature, cold starting and initial running.

The filtered air enters the engine thru four intake ports each with a throttle valve.

The idling air (throttle valves closed) is fed thru a separate circuit which, starting from the air cleaner connects to the intake ports downstream of the throttle valves and includes the idle equalizers **12**.

The accelerator pedal is mechanically linked thru the rods **9**, **10** and the relay crank **8** to both the throttle valve lever and the control unit lever. Therefore, any position of the accelerator pedal corresponds to an exact position of throttle valve and control unit levers.

**Description of fuel
injection system**

**Air induction
system
(see the operating
diagram on
next page)**

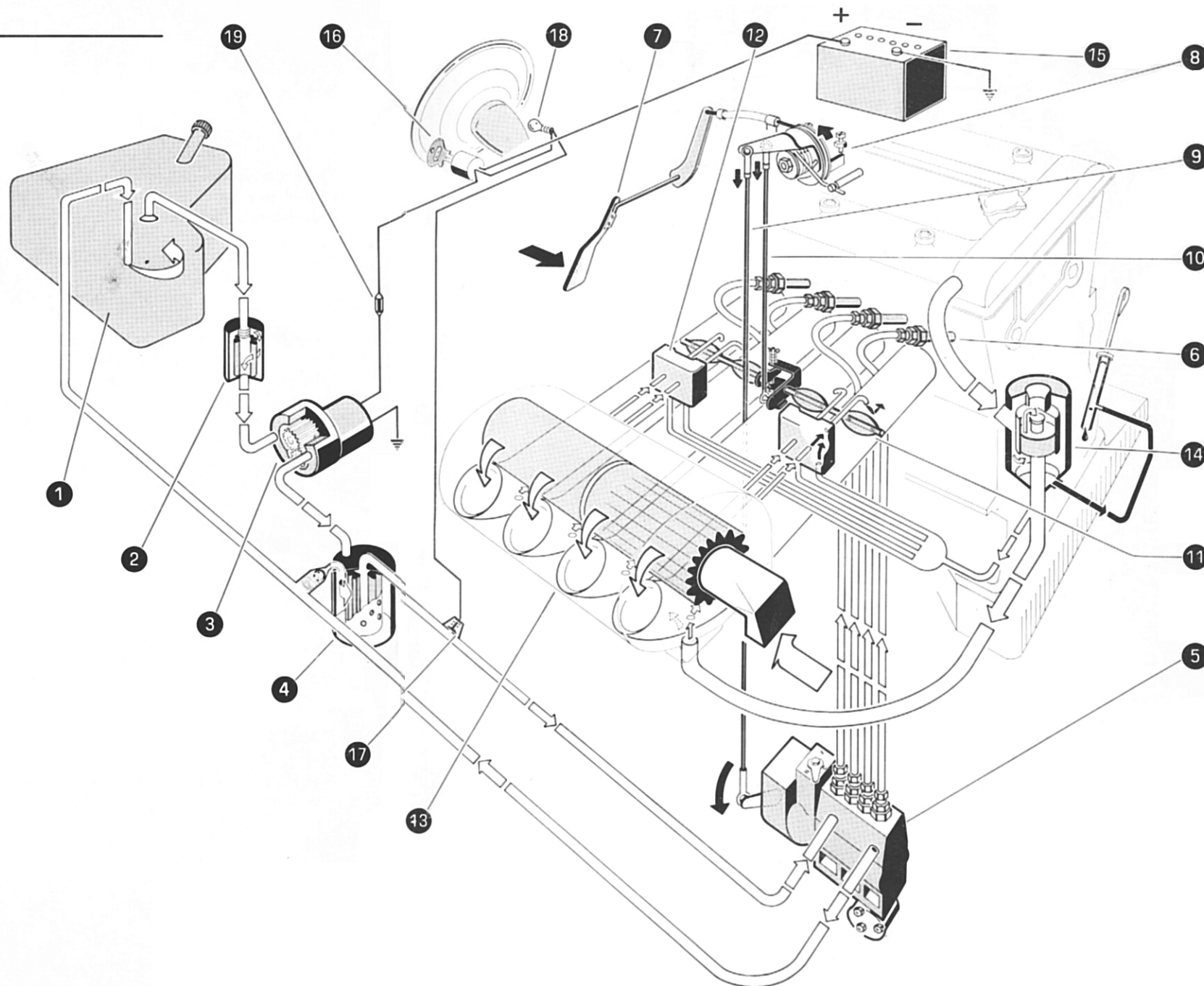

Operating diagram

- 1 Tank
- 2 Tank filter
- 3 Electric pump
- 4 Main filter
- 5 Injection pump
- 6 Injectors
- 7 Throttle pedal
- 8 Relay crank
- 9 Relay crank-to-control unit rod
- 10 Relay crank-to-throttle rod
- 11 Throttle valve throats
- 12 Idle equalizers
- 13 Air cleaner
- 14 Oil separator
- 15 Battery
- 16 Ignition switch
- 17 Pressure switch
- 18 Low fuel pressure warning light
- 19 Fuse

Fuel feed system

Inserting the key in the ignition switch **16** and rotating clockwise to the first click will operate the electric pump **3**. The gasoline flows from the tank **1** thru tank filter **2** and main filter **4** and feeds the injection pump **5**.

The excess fuel, acting also as a coolant for the injection pump, before returning to the tank, passes thru a calibrated orifice which regulates the fuel pressure within the injection pump. A pressure switch **17** inserted in the delivery pipe will switch on the warning light **18** on dashboard if a pressure drop occurs in fuel lines.

A pressure relief valve in the main filter limits the fuel pump outlet pressure bypassing fuel to the recovery pipe.

**Crankcase
ventilating system**

The exhaust gases and the oil vapors developed during engine operation collect in the camshaft cover; from here they are sucked in the combustion chambers and burned.

The crankcase ventilating system controls gases both at high engine RPMs and at idling speed when the throttles are closed.

When the throttles are fully opened the vapors flow thru the hoses to the oil separator **14** and to the manifold chamber communicating with the intake ports.

When the throttles are partially closed, the secondary circuit comes into operation; such a circuit starts from the oil separator **14** and conveys unburned gases and vapors directly into the intake ports downstream of the throttles by means of the equalizers **12** provided with calibrated orifices. The oil collected in the separator returns to the pan via a suitable hose.

Warning

Any adjustment or servicing of the injection system must be entrusted only to an Alfa Romeo Dealer.

The air cleaner is equipped with two pleated elements offering the maximum filtering surface. At the prescribed intervals remove the cover of the filter, withdraw the elements and **clean them carefully from inside with low pressure compressed air**. Moreover at the prescribed intervals change the elements.

Air cleaner

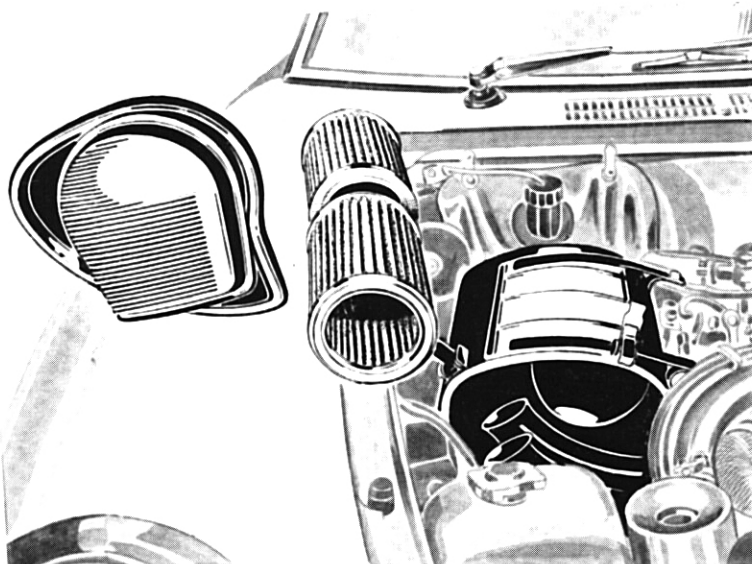

Replacing the main
fuel filter element

At the prescribed periods replace the main fuel filter element. To provide room for this operation, the air cleaner must be removed as follows:

- detach the two upper anchoring straps at manifold side;
- loosen at the engine side the four clamps on the intake hoses; free the crankcase ventilation hoses from the oil separator;
- disconnect the four idle hoses from equalizers on cleaner body (see illustration on page 66).

To change the element proceed as follows:

- disconnect the battery negative terminal and the positive starter cable;
- clean carefully the outside of filter body and nearby lines to make sure no foreign matter could enter the filter on reassembly;
- slacken the bolt securing the filter to its bracket and remove the filter;
- withdraw the filter element;
- get rid of foreign matter that may have collected in the housing and fit a new element; also replace, if damaged, the gasket between housing and bracket and the sealing ring on bolt.

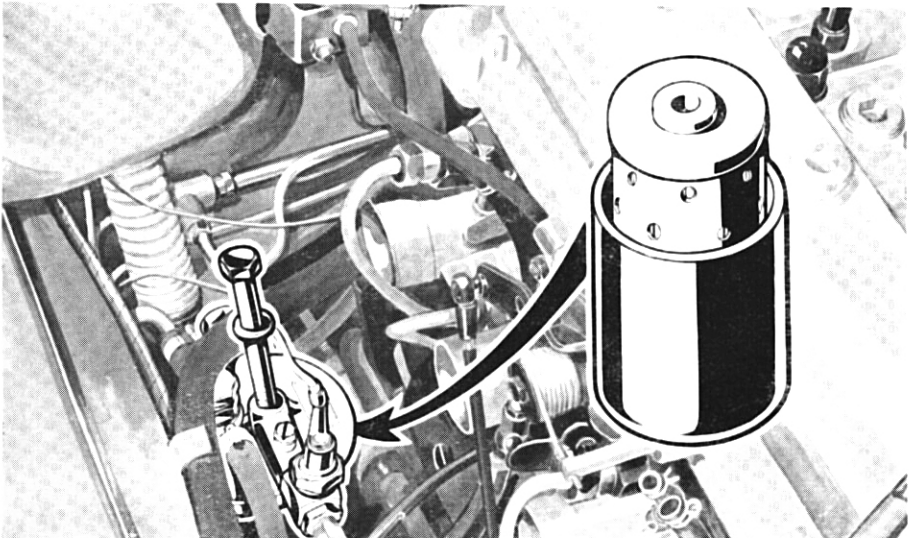

At the prescribed periods, replace as follows the tank filter (throw away type) located at the rear underbody of the car;

- slacken the bolt on the clamp securing the filter to the underbody;
- loosen the clamps securing the hoses to the filter inlet and outlet adapters; it is advisable to blank out temporarily the pipe from fuel tank;
- remove the filter and replace it with a new one by proceeding in reverse order of removal; take care to fit the hoses properly.

Replacing the tank fuel filter

TROUBLE	POSSIBLE CAUSE	REMEDY
Low fuel pressure warning light does not flash on when ignition key is turned.	Fuse no. 6 blown. Warning light bulb burned out.	Replace fuse. Replace bulb.
Low fuel pressure warning light stays on (fuel pump operates: a light buzzing can be heard).	Fuel tank empty.	
Low fuel pressure warning light stays on (fuel pump fails to operate).	Fuse in the additional fuse holder blown.	Replace fuse.
Unsatisfactory driveability and road performance; hesitations.	Air induction clogged.	Check and replace air cleaner elements, if necessary.

TROUBLE SHOOTING

If the fault cannot be traced and remedied, entrust the inspection and repair to an **Alfa Romeo Dealer**.

The ignition system is of the battery and coil type with a centrifugal advance governor.

Firing order: 1 - 3 - 4 - 2

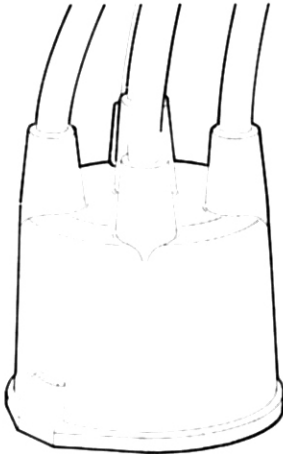

Ignition distributor

At the prescribed intervals:

Check with a feeler gage the contact-breaker point gap.

S = .017 - .019 in.

To adjust, loosen the screws **1** and **2**, insert a screwdriver in the adjustment slot **3** and pry the stationary-point plate back or forth as required.

If contacts are burned or pitted, they may be smoothed with a very fine file and then cleaned with gasoline.

Lightly smear the distributor cam with grease.

Check the inside of the distributor cap for any sign of moisture, carbon deposits or cracks. Check also the central power electrode for free movement in its seat, and that spring action is effective. At last, check the rotor arm for proper insulation and terminals on brush and cap for good operating conditions.

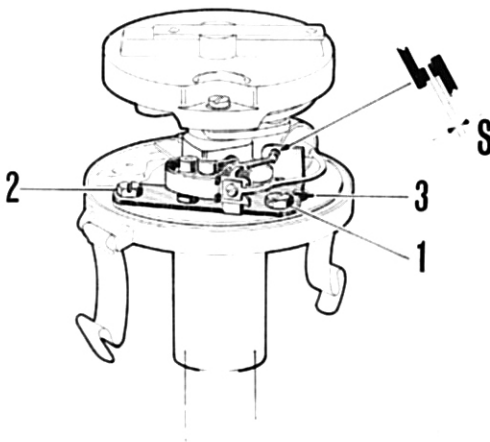

Checking the ignition timing

To check the ignition timing, proceed as follows:

- 1 rotate the crankshaft to bring no. 1 cylinder piston to the compression stroke, that is with both valves closed;
- 2 by slightly rotating the crankshaft, bring the advance mark **F** cut in the drive pulley into line with the reference plate;
- 3 remove the distributor cap and check that the contact-breaker points begin to open when the engine is turned further in its normal direction of rotation.

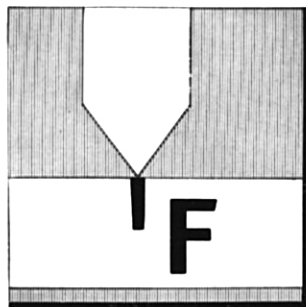

IGNITION TIMING AT IDLE

$1^{\circ}/3^{\circ}$ ATDC

A more accurate check can be made with a **stroboscopic gun** as follows:

run the engine at about 5000 rpm and direct the light from the stroboscopic gun onto the pulley; if the timing is correct, the **M** mark on the pulley will be seen in line with the reference plate.

Timing at idle speed must be adjusted with special care as it affects more greatly the emission levels.

IGNITION TIMING AT HIGH SPEED

$31^{\circ}/37^{\circ}$ BTDC at 5000 rpm

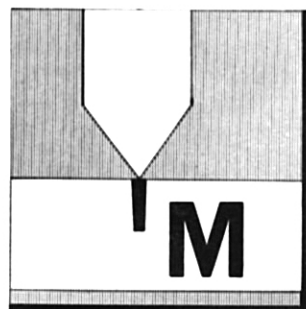

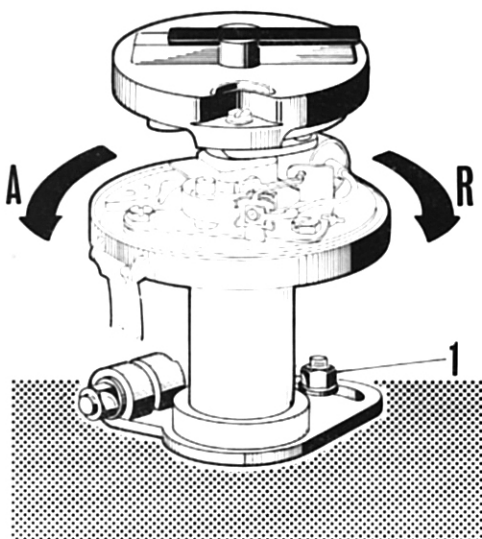

Timing adjustment

If the timing requires adjustment, proceed as follows:

- 1 unscrew the distributor securing nut **1** on the stud so as to allow the distributor to be rotated together with its supporting clamp;
- 2 rotate the distributor body counter-clockwise or clockwise according to whether it is necessary to respectively advance (A) or retard (R) the ignition setting;
- 3 retighten the nut, taking care not to move the distributor body;
- 4 recheck timing.

Timing after removal of distributor from engine

When reinstalling or replacing the distributor, perform the following procedure:

- rotate the crankshaft to bring no. 1 cylinder piston to the compression stroke that is with both valves closed;
- by slightly rotating the crankshaft bring the advance mark **F** on pulley into line with the reference pointer;
- fit the supporting clamp onto the distributor body and tighten the clamp just snug;
- remove distributor cap and rotate the drive shaft by hand to bring the rotor arm in line with the contact for no. 1 cylinder;
- as a trial installation place the distributor on engine and move the supporting clamp so that the stud is centered in the clamp slot **when the contact-breaker points are about to open for no. 1 cylinder**;
- then, remove the distributor with its supporting clamp, taking care not to disturb the distributor body/clamp setting and lock the clamp in place;
- reinstall the distributor and adjust timing as directed above.

The spark plugs are of the surface gap type with four points and a central electrode. The only maintenance required is occasional cleaning with a brush of the central electrode and points. **No routine adjustment is necessary** of the gap between the electrode and points.

If the ceramic insulator is cracked or the electrodes are excessively worn away, the spark plugs must be replaced.

The standard plugs fitted to the engine are **LODGE HL**. A decal, giving the specifications for these plugs, is attached under the hood; here below, the text of the decal is repeated.

In order to comply with the Federal rule regarding the control of air pollution the engine is fitted with **LODGE-HL** spark plugs. These plugs are completely adequate when the automobile is driven at speeds not exceeding the limits specified by speed regulations. If the automobile is driven at sustained speeds higher than the said speed limits, **LODGE-2HL** spark plugs must be used.

The spark plugs should be tightened when cold to a torque of 18-25.3 lb-ft; lubricate the threads with graphite grease before fitting.

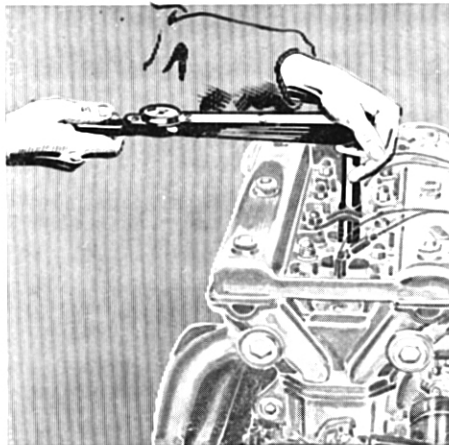

Under no condition can substitute spark plugs be used, unless they are specifically advised and approved by Alfa Romeo. Use of other plugs can promote serious engine damage, as well as alter emission levels.

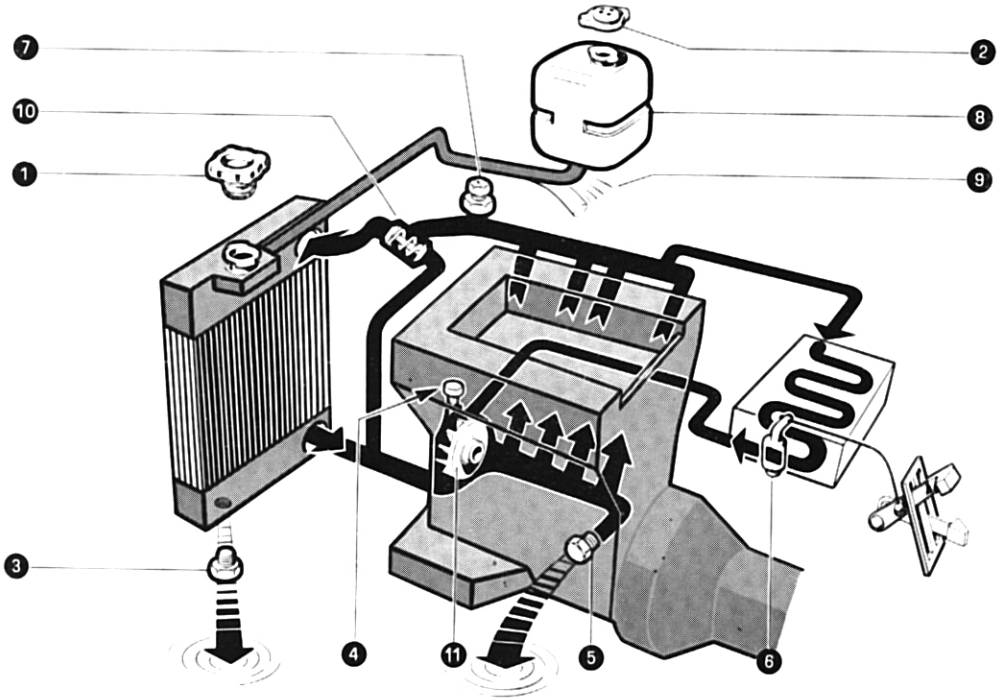

Diagram

- 1 Radiator filler plug
- 2 Reservoir filler plug
- 3 Radiator drain plug
- 4 Bleed screw on pump
- 5 Drain plug on crankcase
- 6 Heater cock
- 7 Bleed screw on manifold
- 8 Reservoir
- 9 Supply line from reservoir to radiator
- 10 Thermostat
- 11 Centrifugal pump.

The cooling circuit is provided with a compensating reservoir containing a special **Alfa Romeo Coolant Mixture** which gives full protection against freezing down to -5°F .

Cooling circuit

To ensure the efficient operation of the cooling system, the following procedure should be observed.

Occasionally, check level of coolant in the reservoir: this should be done **exclusively with a cold engine** as with a hot engine the level may increase remarkably, even after stopping the engine.

The level of mixture in the reservoir should never fall below the « Min » nor exceed the « Max » marks.

To top up use Alfa Romeo Coolant Mixture drawn from suitable containers available by **Alfa Romeo Dealers**.



If too frequent a topping up is required, have the cooling system checked by an Alfa Romeo Dealer.

Should sudden and excessive leaks be experienced from the system, the use of fresh water is allowed provided that the specified mixture is restored and trouble remedied **as soon as possible** by an Alfa Romeo Dealer.

WARNING

Never remove the radiator plug unless absolutely necessary; in any case, to avoid severe injuries, wait that the liquid is cooled down to room temperature.

**Changing the
coolant mixture**

Every 18,000 miles (or once a year whichever comes first) have the coolant mixture renewed by an Alfa Romeo Dealer after the circuit has been flushed with a suitable descaling compound.

**Draining
and replenishing
the system**

To drain and replenishing the cooling system proceed as follows (refer to the illustration on page 76):

Draining:

- Remove radiator filler plug **1**.
- Unscrew the drain plug **3** and the bleed screw **7** on manifold.
- Turn on the heater cock **6**.
- Remove the drain plug **5** on crankcase; let liquid drain off and empty the reservoir **8** by detaching the pipe **9**.
Reinstall drain plugs **3** and **5** and reconnect the pipe to the reservoir.

Replenishing

- Remove radiator and reservoir filler plug and turn on the heater cock.
- Open the bleed screw **7** on manifold and **4** on pump.
- Pour antifreeze mixture thru radiator filler port until the coolant escapes from the bleed screw **4**; then screw in the latter. Go on in adding until the coolant appears at the bleed screw **7** on manifold.
- With the bleed screw on manifold opened and no plug on filler port of radiator start the engine and keep it idling for a few seconds in order to bleed air completely.
- Close the bleed screw on manifold.
- Add mixture to radiator filler port until full.
- Add mixture also to reservoir until « Max » level is reached.
- Put the filler plugs on reservoir and radiator.

The mixture in the cooling circuit gives full protection against freezing down to -5°F .

In places where the temperature falls below -5°F , the mixture can be strengthened as directed on page 27.

It is recommended that this operation be entrusted to an Alfa Romeo Dealer.

IMPORTANT NOTE

If the tension is insufficient, the belt will slip and wear prematurely; furthermore:

the cooling action will be affected because of the reduced speed of the fan and pump;

the battery charging current will be reduced owing to the slower alternator speed.

If the tension is excessive, the alternator and pump bearings will be overloaded with the consequent risk of damage.

Therefore it is necessary to check the belt tension at the prescribed intervals.

Adjusting the tension of fan, coolant pump and alternator driving belt

The tension is correct when on pressing the belt down the amount of play is approximately $\frac{1}{2}$ in.

To tighten the belt unscrew the nut on the adjusting arm and move the alternator outwards.

Carefully retighten the nut after adjusting the belt tension.

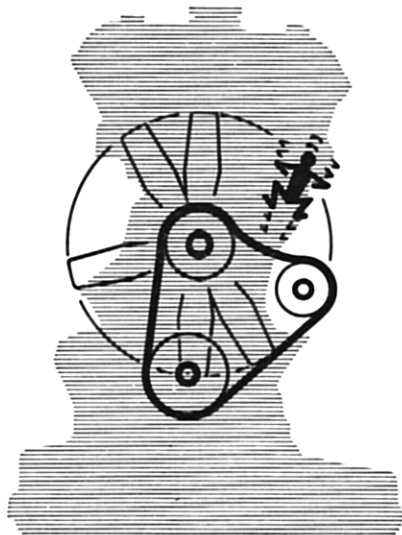

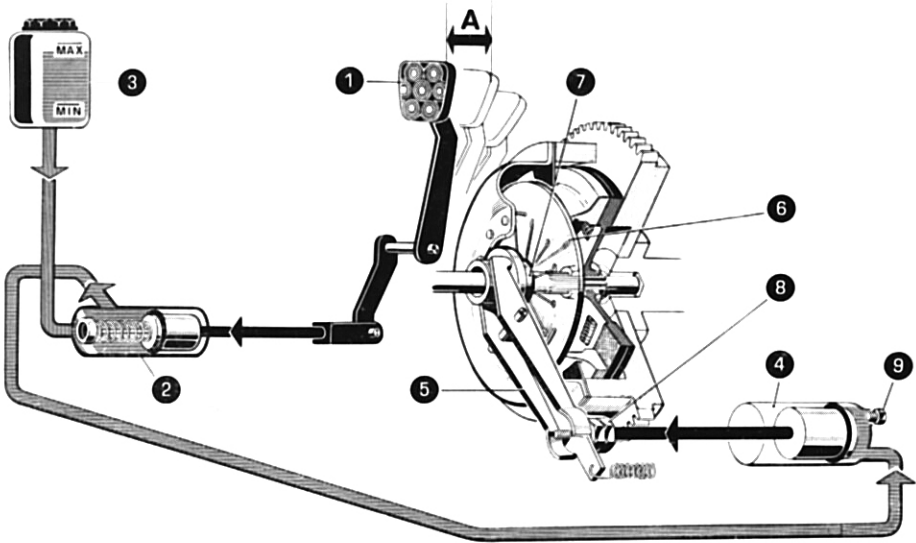

Operating diagram

- A Pedal free travel
- B Actuating rod free travel
- 1 Pedal
- 2 Master cylinder
- 3 Fluid reservoir
- 4 Actuating cylinder
- 5 Disengagement lever
- 6 Diaphragm spring
- 7 Throwout bearing
- 8 Adjusting nuts
- 9 Air bleed screw.

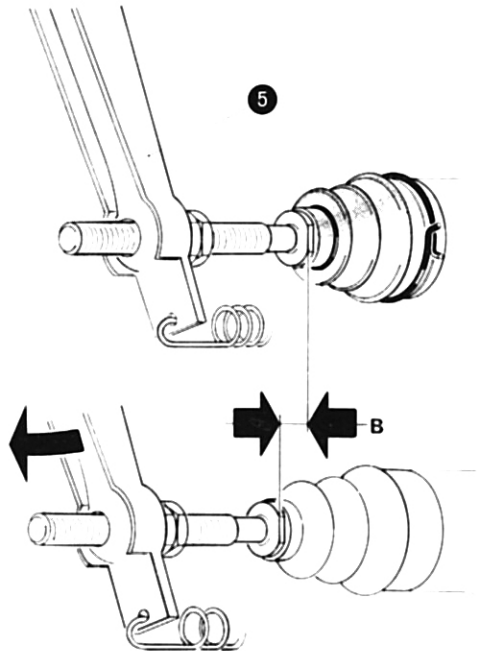

The clutch is of the hydraulically-operated single-plate dry type. The pedal **1** acts on the master cylinder **2** supplied by the fluid reservoir **3**.

When the clutch pedal is depressed the fluid under pressure actuates the piston in the cylinder **4** connected to the lever **5**.

The pressure plate is controlled by means of the diaphragm spring **6**. **The clutch pedal free travel A should be about 1 1/4 in.**

When, owing to wear on the clutch disc facing, the pedal free travel is reduced to **3/4 in.** the free travel must be restored.

Measure with a rule the free travel **B** of the actuating rod on the lever **5**, by depressing the pedal until the throwout bearing **7** contacts the spring **6**; the travel **B** should be about .08-.10 in. If the travel is shorter, act on adjusting nuts **8**.

At the same time make sure that, by pressing the pedal as far as it will go, the actuating rod can move thru a total travel of .53-.56 in.

If any component of the system has been removed, thoroughly bleed the circuit.

**Adjusting the
pedal free travel**

Transmission ratios

1st	3.30 : 1
2nd	1.99 : 1
3rd	1.35 : 1
4th	1.00 : 1
5th	.79 : 1
Rev.	3.01 : 1

The transmission has 5 synchromesh forward gears and one reverse.
The gearshift lever is floor mounted.

RM = Reverse
S = Synchromesh
F = Neutral

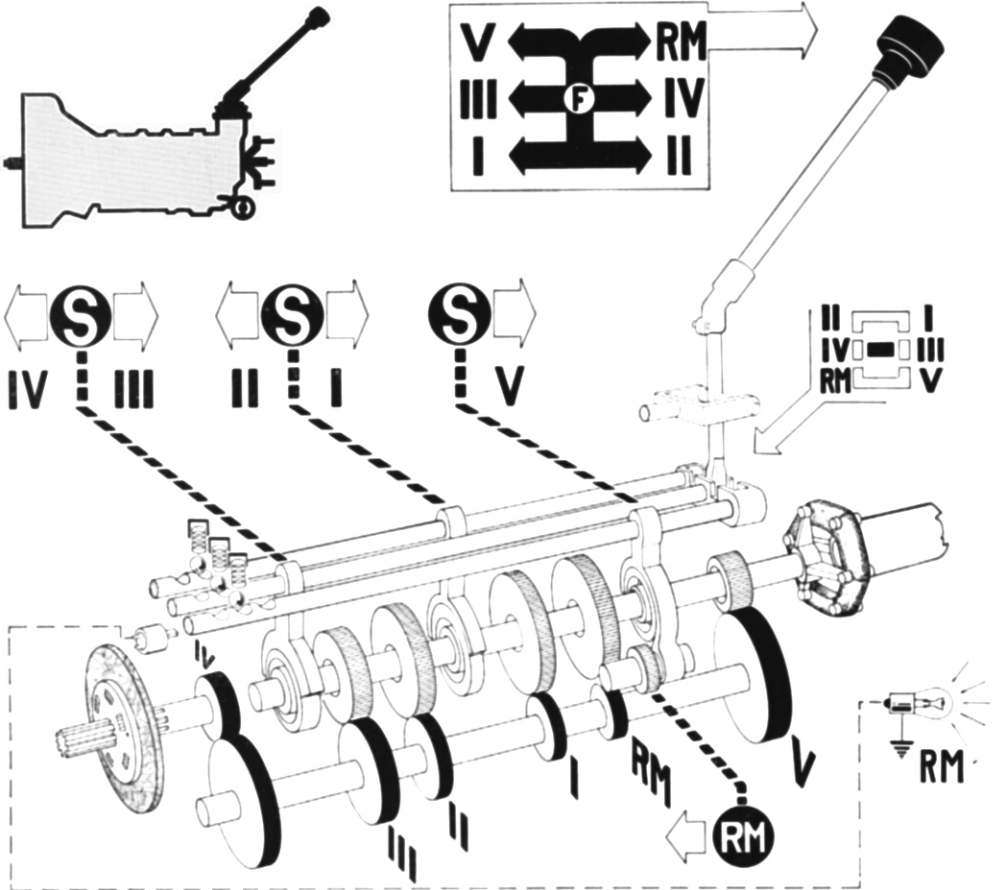

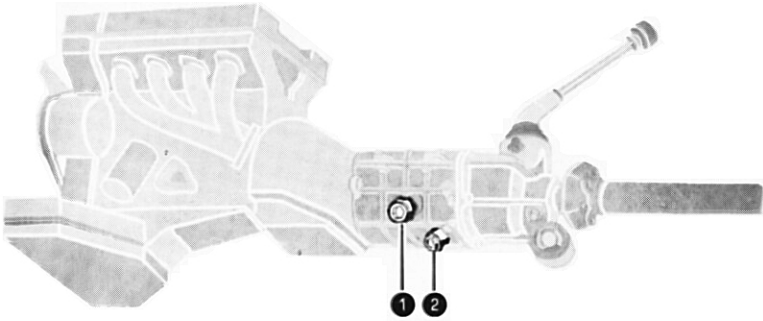

Any inspection or adjustment of the transmission must be done only by an **Alfa Romeo Dealer**.

1 Filler plug.

Check that transmission is full of oil to the bottom edge of the filler orifice.

2 Drain plug.

The drive shaft is in two sections and has an intermediate flexible support attached to the body.

The front section is provided with a rubber coupling at the transmission end; a universal joint is provided at each end of the rear section.

DRIVE SHAFT

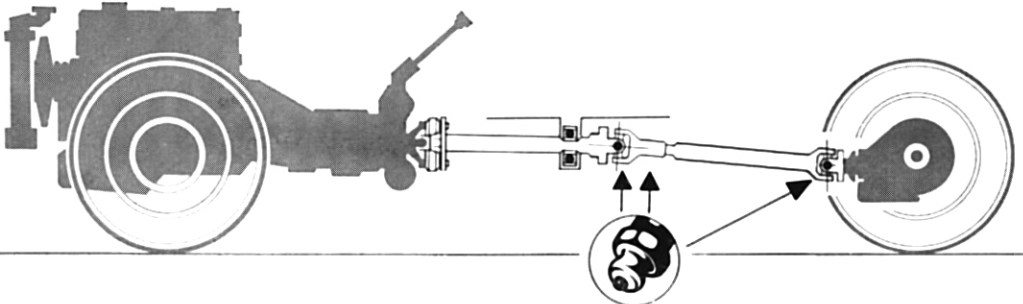

Grease the universal joints and the slip yoke at the scheduled intervals.

The live axle is attached longitudinally to the supporting structure by means of two trailing arms with rubber bushes at the ends; transverse attachment is effected by means of a T-arm hinged to the body and to the rear axle thru rubber bushes. The final drive is of the hypoid type.

Overall ratios

with 41 : 9 final drive

1st	15.049 : 1
2nd	9.055 : 1
3rd	6.172 : 1
4th	4.555 : 1
5th	3.603 : 1
Rev.	13.710 : 1

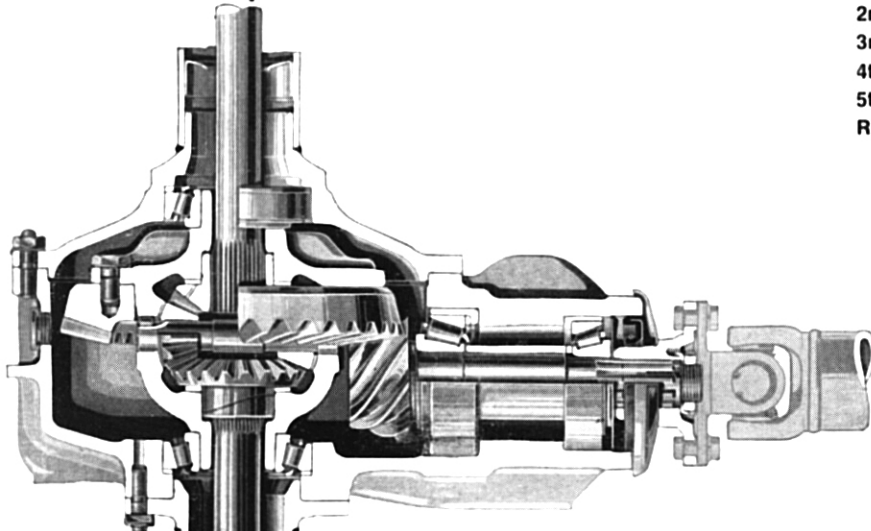

Check oil level or change the oil at the prescribed intervals.

Filler plug.

Check that differential is full of oil to the edge of the filler orifice.

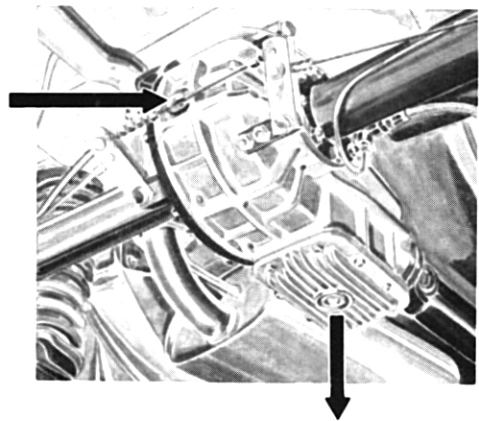

Drain plug

The front wheels are independently suspended and connected to the body by A-arms. Coil springs and double-acting hydraulic telescopic shock absorbers are located between the lower arms and the body. The suspension system is completed by a transverse stabilizer rod which improves the stability of the vehicle when cornering. Upward movement of the arms is restricted by bumper pads situated near the springs. Downward movement is restricted by pads attached to the cross member.

Suspension components require no regular lubrication. Whenever the damping action of the shock absorbers is uneven, have them checked by an Alfa Romeo Dealer.

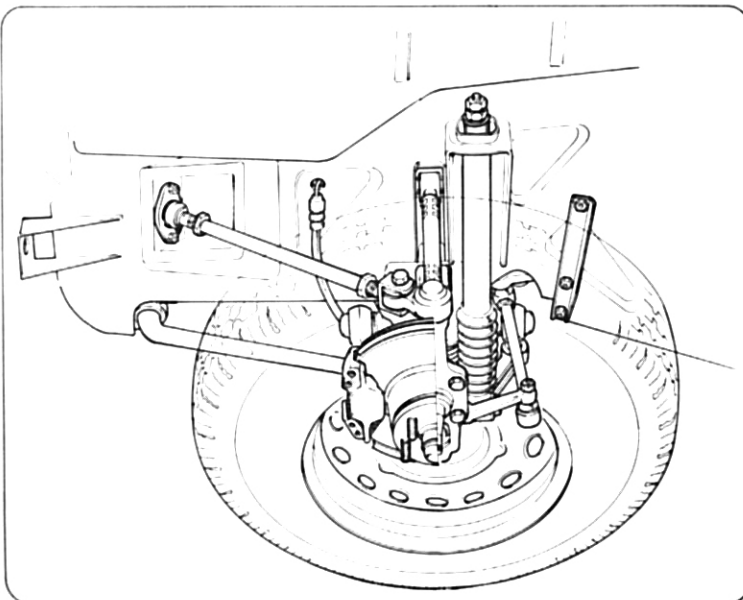
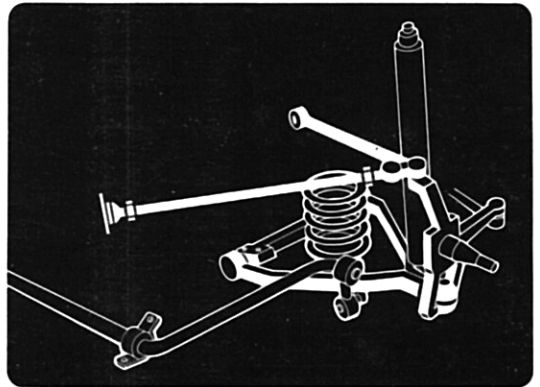

The rear suspension consists of coil springs and large diameter telescopic shock absorbers coaxial with the springs. The suspension system is completed by a transverse stabilizer rod linked to the trailing arms and the body.

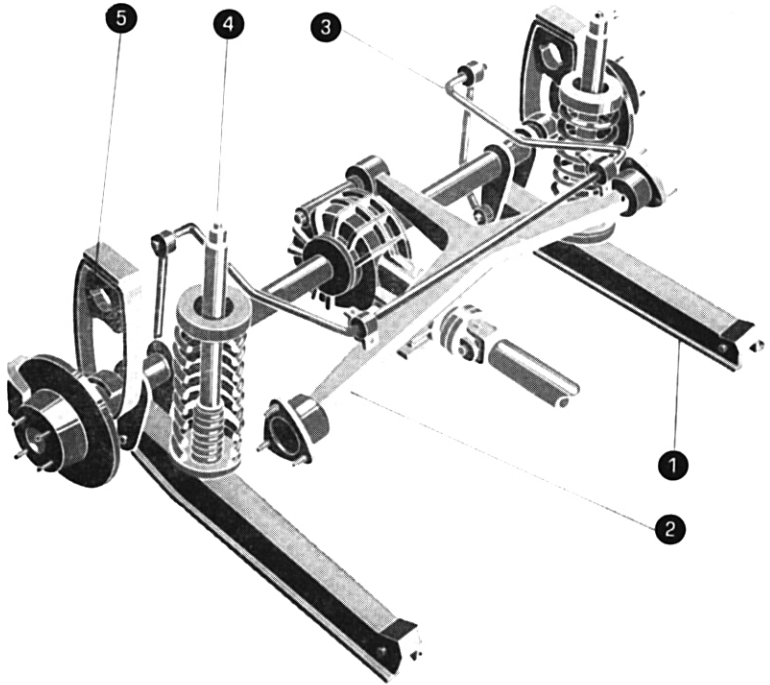

- 1 Trailing arm
- 2 T-arm
- 3 Stabilizer rod
- 4 Shock absorber
- 5 Rubber buffer and rebound strap.

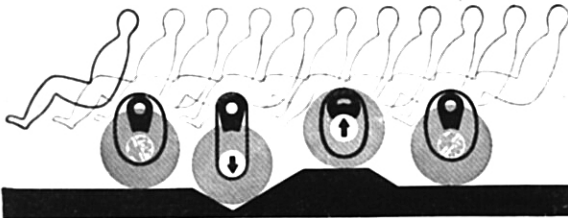

The rebound of rear axle is limited upward by rubber pads and downward by fabric and rubber straps.

The suspension units do not require any regular lubrication. Whenever the damping action of the shock absorbers is uneven, have them checked by an Alfa Romeo Dealer.

This model is produced alternatively with steering of the worm and roller or recirculating ball type.

Recirculating ball steering.

At the prescribed intervals check:

- the oil level in the steering box (by removing the plug 1 shown in the figure);
- the steering linkage joints for play.

The steering of the recirculating ball type does not require any regular adjustment.

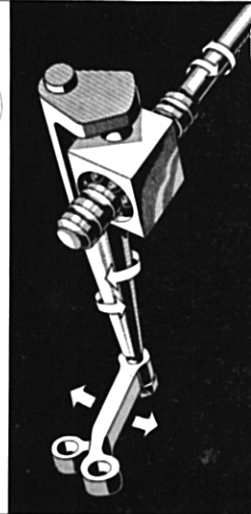
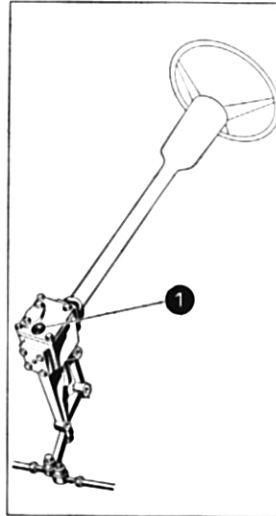

Worm-and-roller steering.

At the prescribed intervals check:

- the oil level in the steering box (by removing the plug 1 shown in the figure);
- the steering linkage joints for play;
- the worm and roller for play (adjust with screw 2, if necessary).

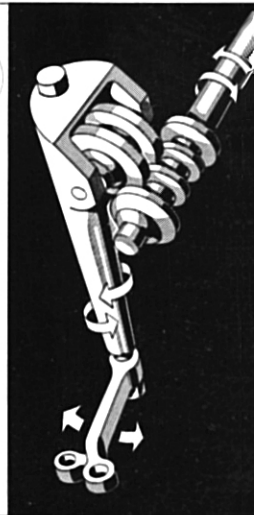
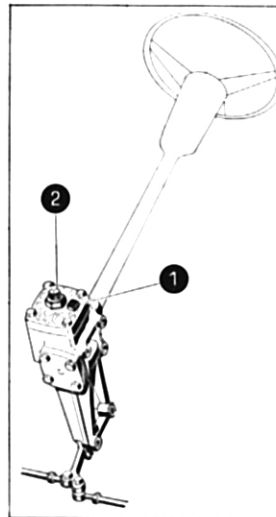

The ball and socket joints of the rods do not require any lubrication.

**Toe-in
and camber**

To avoid uneven and premature tire wear, and to ensure positive and stable steering, front wheel toe-in and camber must be set to the prescribed values.

Toe-in and camber vary according to the car load: the values should be checked with the car standing on level ground, with full pan, tank and radiator, with the tires inflated to the prescribed pressures, with spare tire and tools and with a load corresponding to that of four persons, i.e. about 620 lbs. for Berlina and 2 persons (310 lbs) for GT Veloce and Spider Veloce.

In order to obtain the correct results these checks should be carried out by specialized mechanics using suitable equipment.

It is recommended that this operation should be entrusted to an Alfa Romeo Dealer.

**Toe-in
adjustment**

Lock steering wheel in the central position, i.e. with the spokes symmetrically disposed in relation to the vertical;

starting with the track rod **1** on the steering box side, place the corresponding wheel so that the toe-in is **.06 in.**;

measure the length thus obtained of the track rod on the steering box side and shorten by **.2 in.** the arm **2** on the other side;

bring the right-hand wheel to **.06 in.** toe-in by adjusting the center track rod **3**;

**Length of
track rods**

As measured between ball joint centers, the length should fall within the following limits:

1 **2** $10.71 \pm .3 \text{ in.}$

3 $21.26 \pm .4 \text{ in.}$

If these values cannot be restored, the cause will probably be attributable to distortion of the body resulting from a collision.

Chassis maintenance

FRONT WHEELS

Non-adjustable; check chassis and suspension arms for distortion, if necessary.

Camber

The turning circle may be adjusted by means of the screws **4** indicated in the figure below.

Turning circle

$$\text{Camber } B = A \begin{array}{l} + .20'' \\ - .04'' \end{array}$$

$$\text{Toe-in } C = D + .12''$$

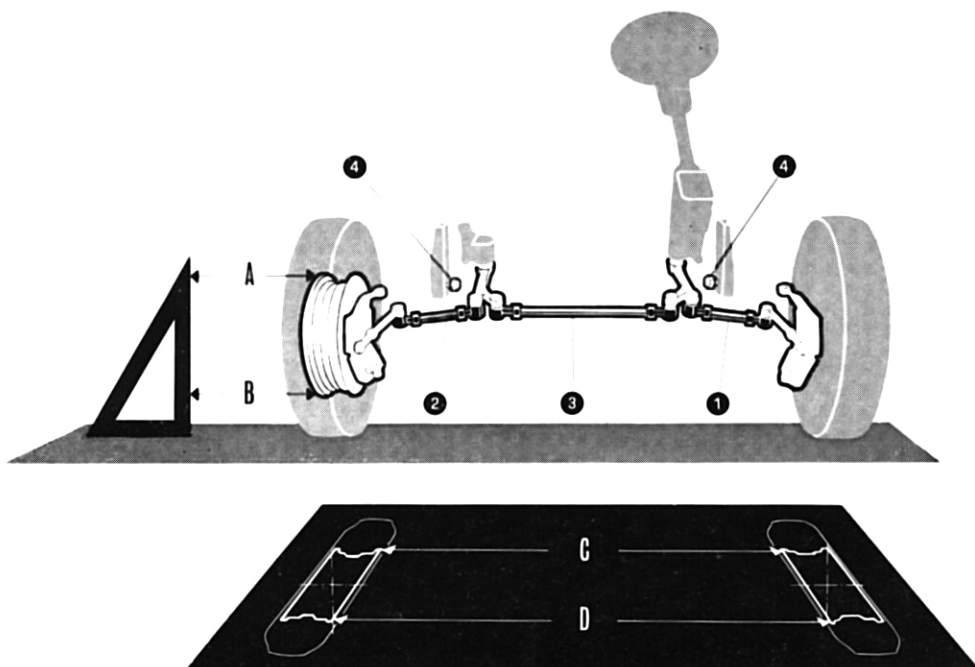

Operating diagram

- 1 Brake pedal
- 2 Fluid reservoir
- 3 Master cylinder
- 4 Front brakes booster
- 5 Rear brakes booster
- 6 Suction port
- 7 Plungers
- 8 Friction Pads
- 9 Discs
- 10 Bleed screws
- 11 Pressure switch cluster
- 12 Pressure switch for brake warning light
- 13 Brake warning light
- 14 Stop light cable
- 15 Modulating valve

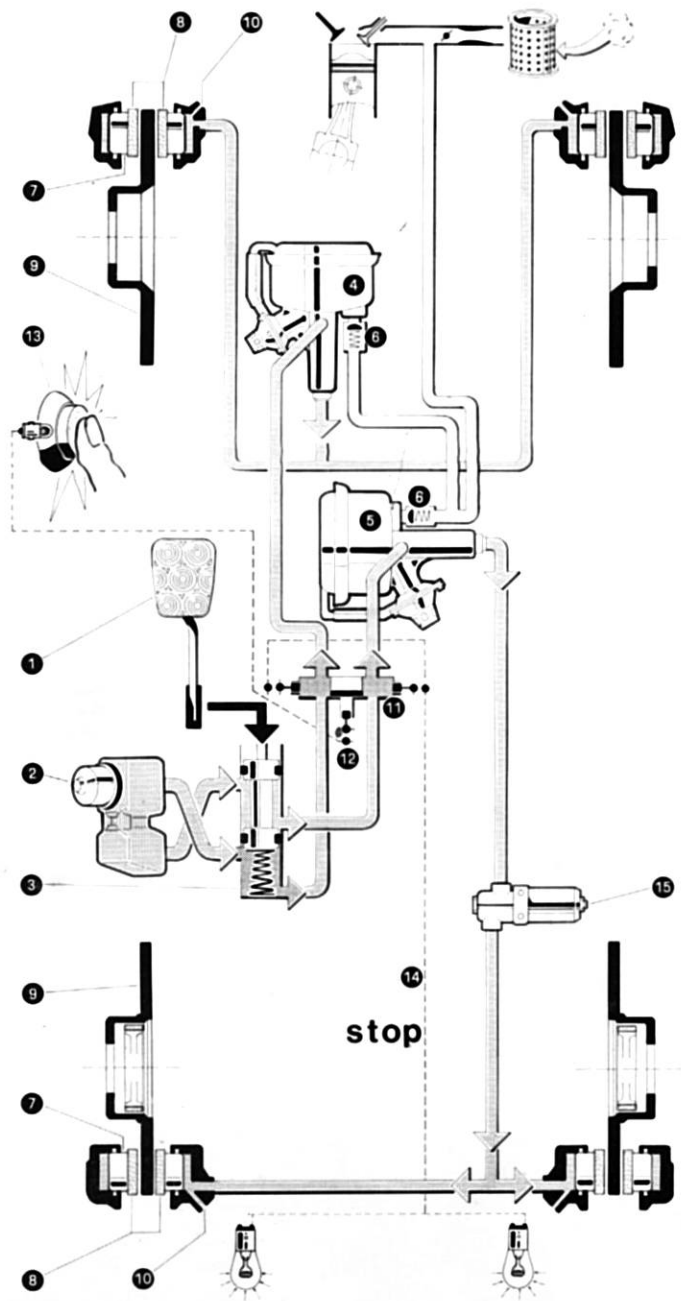

The brake system consists of four disc brakes operated by a dual hydraulic system.

Each one of the separate circuits, front and rear, is servo assisted by a vacuum booster. The boosters are controlled by a tandem master cylinder, with one cylinder operating the front brakes and the other cylinder the rear brakes.

The friction pads of the front and rear brakes are directly actuated by the cylinders integral with the calipers.

The brakes are self-adjusting.

A modulating valve, inserted in the rear brake circuit, regulates the pressure between front and rear brakes to provide balanced braking action.

WARNING: the modulating valve must never be tampered with; specifically, do not attempt to act on the adjusting nut as it is factory sealed.

A red warning light, located in the instrument panel (Berlina, 16 page 15 - GT Veloce, 12 page 17 - Spider Veloce, 23 page 19) will alert you if either of the hydraulic systems fails to operate.

In this event slow down and get your car to an authorized Dealer at the earliest possible opportunity to have the brake system serviced.

WARNING: push down frequently the warning light, of the push-to-test type, to see that it, by coming on, operates properly.

To maintain the brakes in good operating condition, follow the servicing instructions given below:

- Take care to prevent the **minimum level** of fluid in the reservoir from falling below the **maximum level** by more than a quarter.
- For renewal or topping up, it is absolutely essential to use only



from freshly opened sealed containers.

When adding fluid, leave the strainer in place so as to filter the fluid.

- Renew the brake fluid at the prescribed periods. For effective and reliable operation of the brake system, the pipes must always be full of fluid and free of air bubbles.

Excessive and spongy brake pedal action is an indication of the presence of air bubbles in the system.

Compressed air must not be used for replenishing the system.

Should flushing of the brake circuit be required, use exclusively fluid of the specified type.

Compressed air or alcohol must on no account be used to dry a flushed system.

Dual brake system

Rear

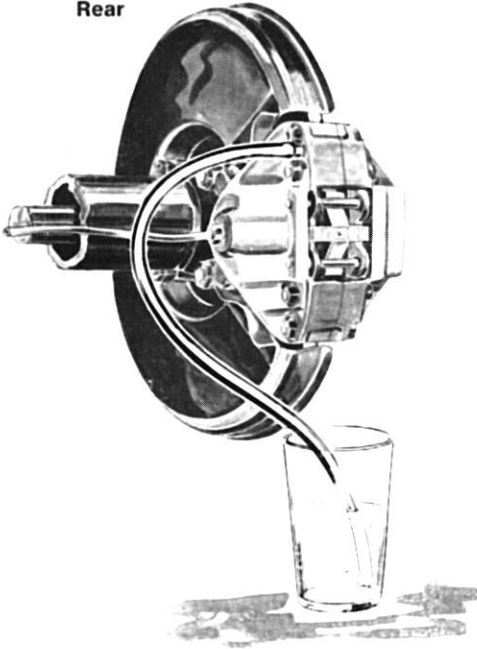

Front

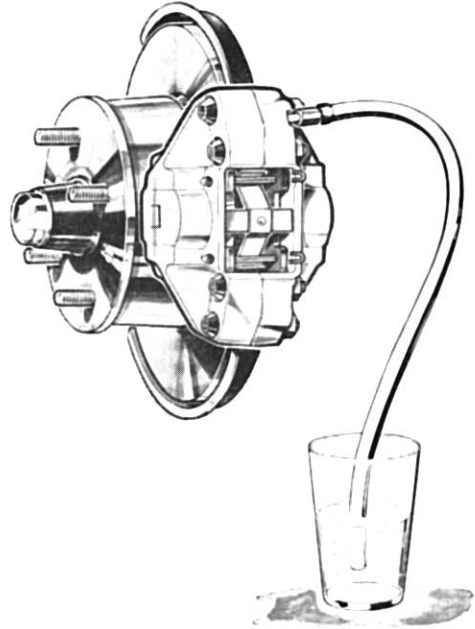
**Air bleeding**

Bleeding should be performed on front or rear circuit with the greatest care and following these instructions:

- 1 Fill the reservoir, if necessary, with the genuine fluid freshly drawn from sealed containers; during bleeding operations pay attention that fluid level does not drop below the full by more than a quarter.
- 2 Bleed as follows:
 - Push a rubber pipe over the bleed screw; the other end will lead to a glass container for collection of fluid.
 - Loosen the bleed screw.
 - Depress the brake pedal several times allowing it to return slowly until the pipe discharge fluid free from air bubbles.
 - Hold the pedal down and tighten the bleed screw.

As one circuit has been bled, proceed by bleeding the other in the same way.

- ★ If the bleeding has been carefully performed, it will be found that when the brake pedal is depressed, direct action on the fluid can be felt, free of resilience, immediately at the end of the free travel. If not, repeat the procedure.

At the prescribed intervals check front & rear pads for wear. Proceed as follows:

- Jack up the car and remove the wheel;
- drive the upper retaining pin out of caliper;
- remove the cross-shaped spring;
- drive out the lower retaining pin.

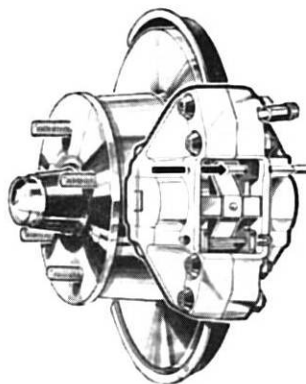

Removal

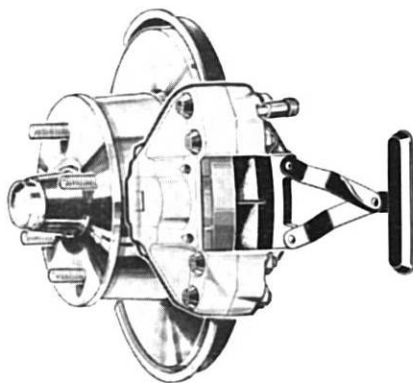
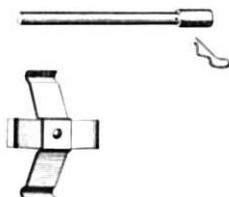

- Withdraw the pads with the puller **A.2.0150**.

Thickness:
new
.6 in.

wear limit
.28 in.
REPLACE

- Check pad thickness.

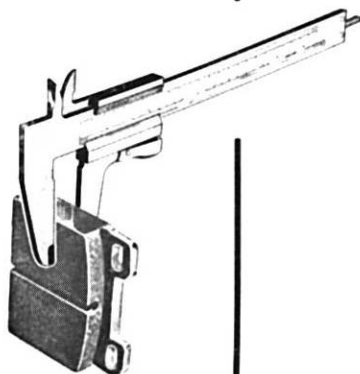

In case of uneven wear of pads, it is advisable to replace the whole set (front or rear).

Pad reassembly

Clean the pad surface: never use mineral base solvents or sharp-edged tools; check that dust excluder and retaining ring are sound; if not, replace them.

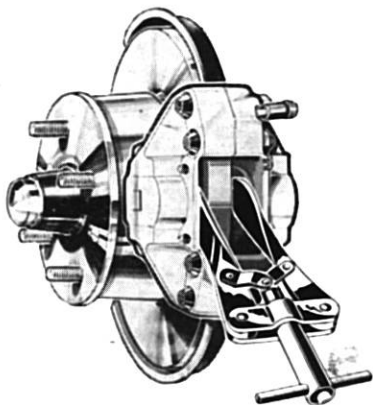

Press the pistons to the bottom of cylinders with the resetting tool **A.2.0147**; do not use chance tools which could damage the pistons or the disc.



When resetting pistons care should be taken to prevent fluid overflow from the reservoir.

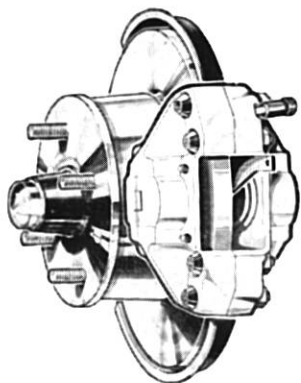

Positioning the pistons

Make sure the pistons are correctly positioned in the caliper by resting the template **A.2.0149** against the reference surface as shown.

- 1 Template
- 2 Piston

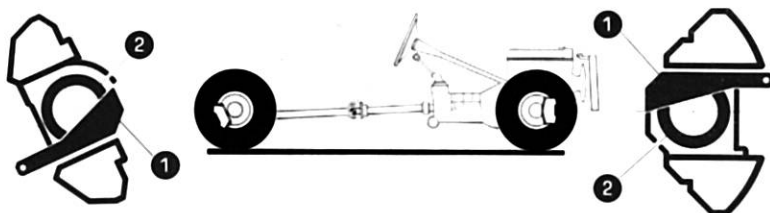

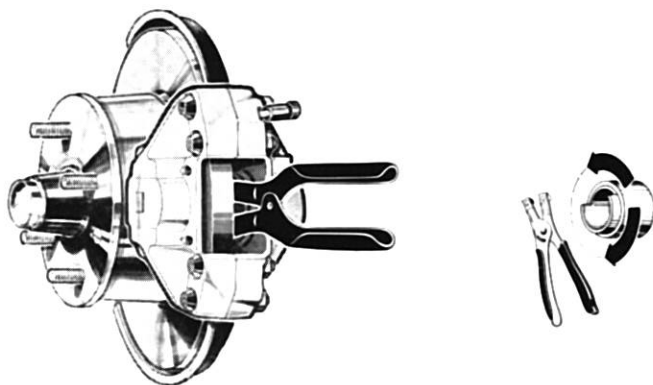
**Pad reassembly**
(continued)

If the pistons are not in the correct position rotate them with the special pliers **A.2.0148/1** for rear brakes and **A.2.0159** for front brakes.

- Insert the friction pads in the caliper; if new pads are fitted, make sure they slide freely in their housing.
- Fit a retaining pin and then the cross-shaped spring; press down the free end of spring so that the other retaining pin can be fitted.
- With a suitable drift push the retaining pins fully home and lock them in place with the safety pins.

When refitting the pads, check the conditions of cross-shaped springs and upper & lower retaining pins and replace, if necessary; however, **these parts must be replaced whenever new pads are fitted.**

**Parking brakes
operating diagram**

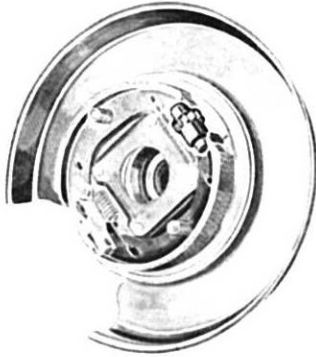

DETAIL VIEW (drum removed)

- 1 Control lever
- 2 Operating levers
- 3 Discs
- 4 Shoes
- 5 Running clearance adjuster
- 6 Slack adjuster

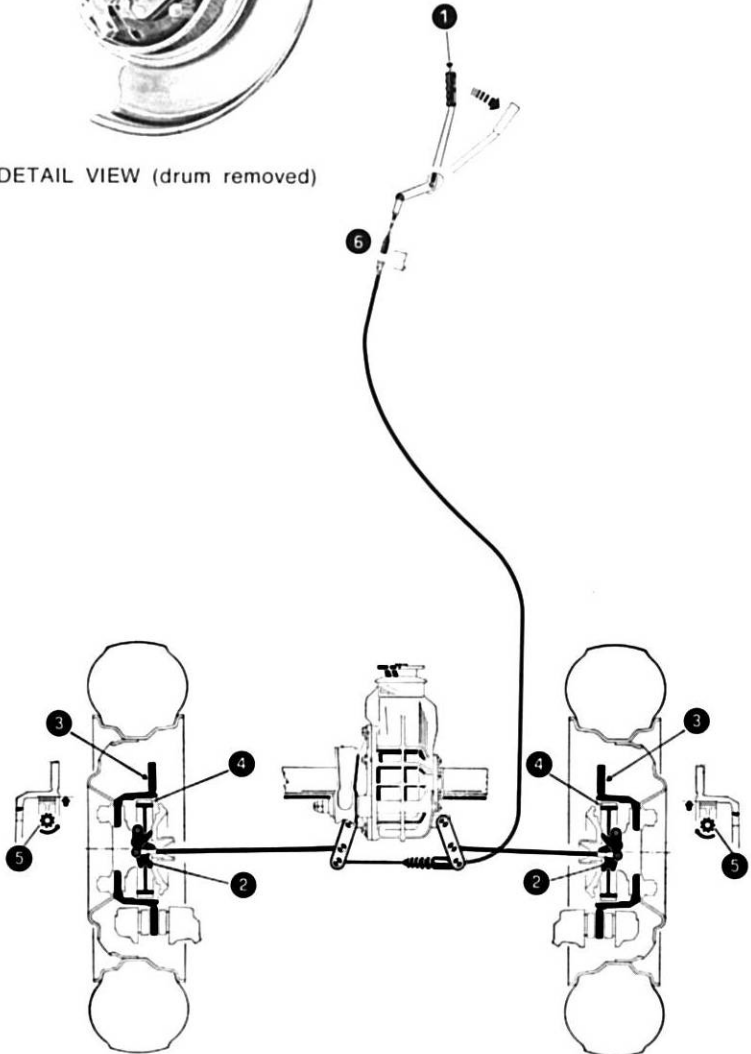

It is mechanically-operated: the rear wheels are locked thru shoes 4 acting against a drum machined in the disc casting. Pulling the lever causes the shoes, via the operating levers 2, to expand thus locking the wheels.

Parking brake

A slack parking brake linkage, due to worn shoe linings, is adjusted as follows, one wheel at a time:

Parking brake linkage adjustment

- jack up the car and remove the wheel; fully release the brake and make sure the control cables to the calipers are slackened;
- act on the running clearance adjuster 5 one notch at a time in the direction shown in the figure until shoes just contact the drum, then back up the adjuster by two-three notches.

Gain access to the adjuster 5 with a screwdriver inserted thru one of the holes in the disc casting; if hole and adjuster are not aligned rotate the disc.

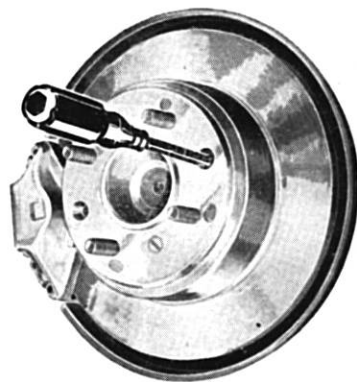

The parking brake is correctly adjusted when the wheels become locked as the lever is drawn thru half its total travel. If, after this adjustment, the linkage is yet slackened proceed as follows:

- rotate the adjuster 5 until shoes contact the drum and lock it;
- take up any slackening in the linkage by means of the slack adjuster 6;
- back up the adjuster 5 by two-three notches; in this condition the brake linkage will be correctly adjusted.

Cleaning instructions

To clean the outside of brake assemblies use suitable detergents mixed with hot water; then thoroughly dry all components with compressed air.

Never use gasoline, trichloroethylene or similar solvents to clean the outside of brakes as these substances are detrimental to the rubber seals.

While servicing the car, be careful not to let lubricants come in contact with the discs and friction pads.

When cleaning the car, it is advisable to mask off the brakes to avoid damaging the brake components with jets of water.

Important warning

In case of accident or damage to the chassis check that the vacuum boosters are undamaged, since even slight superficial body damage may seriously impair the functioning of the brakes.

Do not coast downhill with the engine stopped; there will be no suction in the brake boosters and a greater pressure will be needed with the brake pedal to obtain comparable braking effect.

STOPPING DISTANCES!

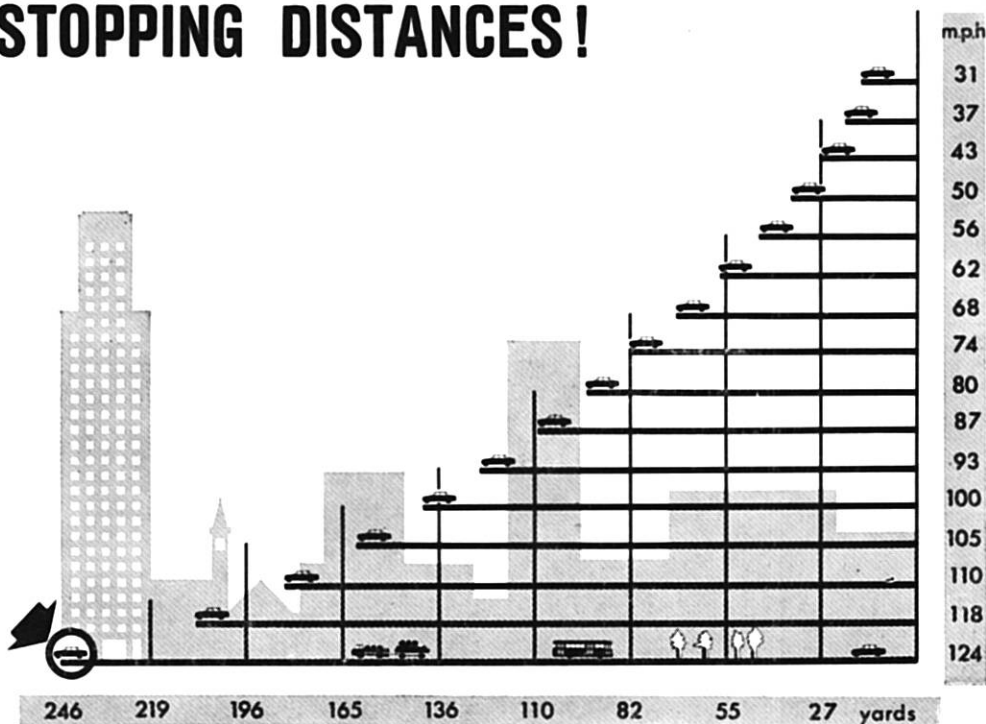

The distance in which the car can be brought to a stop after application of the brakes increases considerably as the speed increases; the distance also varies according to the road surface, and it is much greater when the road is wet or slippery.

The diagram shows stopping distance for various speeds based on ideal conditions, i.e. flat, dry, asphalt roads, good tires, well adjusted brakes and loads properly distributed over the car.

For safety's sake always bear these stopping distances in mind at all times.



Chassis maintenance

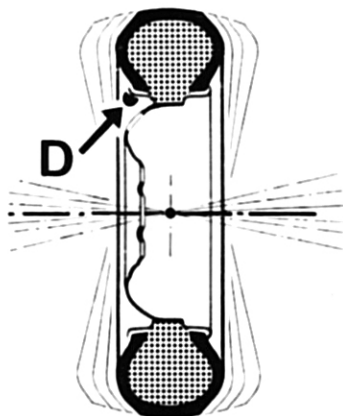
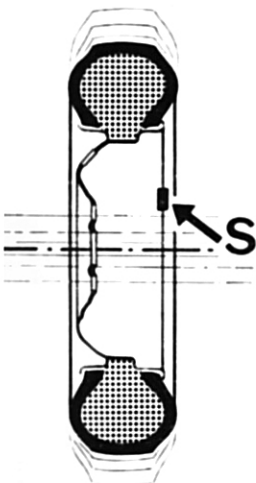

Wheel balancing

Each wheel, complete with its tire, is statically and dynamically balanced at the factory.

Whenever a tire is changed, the wheel must be rebalanced.

It should be remembered that unbalanced wheels cause unstable steering, abnormal steering gear wear and uneven tire wear.

Balance weight location

D Dynamic

S Static

TIRES

RECOMMENDED TIRE PRESSURE (COLD) IN PSI
AT A MAXIMUM-LOADED VEHICLE WEIGHT OF 3340 LBS

Make	Front	Rear
Pirelli	22	23
Michelin	26	26
Kleber Colombes	24	29

Note: For sustained speeds exceeding the limits specified by Federal regulations, inflate to the following pressures:

Michelin	28	31
Kleber Colombes	27	31

RECOMMENDED TIRE PRESSURE (COLD) IN PSI
AT A MAXIMUM-LOADED VEHICLE WEIGHT OF 3000 LBS

Make	Front	Rear
Pirelli	24	26
Michelin	20	24
Kleber Colombes	24	26

RECOMMENDED TIRE PRESSURE (COLD) IN PSI
AT A MAXIMUM-LOADED VEHICLE WEIGHT OF 2760 LBS

Make	Front	Rear
Pirelli	24	26
Michelin	20	24
Kleber Colombes	24	26





YES

NO

NO



Tire inflation pressure

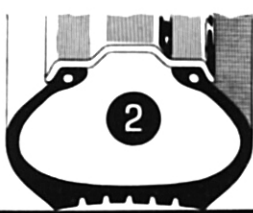

- ① The tire gives optimum performance, the tread works over its entire width, thus ensuring **uniform tire wear and long life**.
- ② The tire will overheat: **the sides of the tread will wear quickly** and the **tire plies will tend to separate**.
- ③ Riding comfort will be reduced, and the tire will suffer from **excessive wear in the center of the tread and vulnerability to knocks**.

Correct

Too low

Too high



Chassis maintenance

Changing over

To ensure even and uniform tire wear and long tire life, front and rear wheels and the spare should be changed over regularly.

Michelin diagram

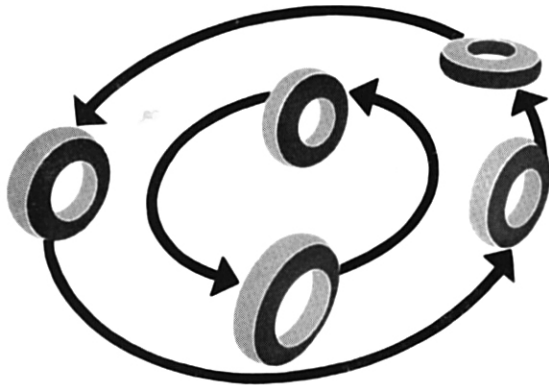

Pirelli diagram

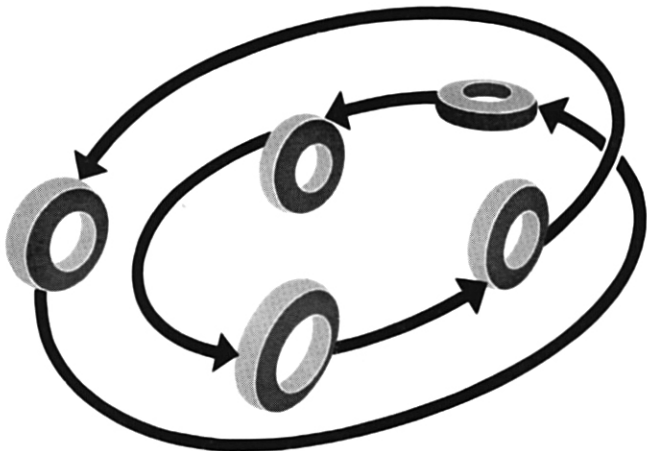

Body maintenance

**EXTERNALLY
& INTERNALLY**

The body should be washed frequently, depending on the use of the car, the environmental conditions and the state of the roads. Moreover the lighter is the finish paint shade the more frequent the car should be washed.

Avoid washing the car in the sun and proceed as follows:

- first flush the car all over with jets of water to remove the dust;
- prepare a solution of suitable detergent in water (2% in weight);
- with the solution and a sponge wipe down the whole body;
- rinse thoroughly with plenty of water;
- dry with compressed air, if possible, then with chamois leather.

Note: for cleaning the outside of brakes refer to page 98.

Washing the car

To put fresh gloss on the paintwork, polish once or twice a year with a polish suitable for synthetic or nitrocellulose paint, according to the type of paintwork on the car.

On the chromework use gasoline to remove grease and a suitable compound to take out any scratches.

Use only woollen cloth for polishing.

Do not use gasoline or solvents on rubber mouldings and weatherstrips. When refuelling or lubricating, be careful not to splash gasoline or hydraulic fluid on the paintwork.

Polishing

Use only a very soft cloth or chamois leather for cleaning the windshield and windows. If the panes are very dirty, use windshield washer fluid or water mixed with alcohol.

Cleaning the windows

Grease, oil and tar stains may be removed from the paintwork by applying gasoline to the stained area, and then rubbing it with a dry cloth. If the tar deposits have hardened, use one of the many preparations available on the market.

Removing stains

Periodically dust the inside upholstery using a vacuum cleaner if possible.

To remove oil and grease stains, use diluted ammonia on the cloth parts and vaseline on the leather.

Use trichloroethylene or neutral soap to remove stains from the carpets. The steering wheel and control knobs may be cleaned with gasoline.

Upholstery

Laying the car up

If the car will be left unused for any length of time the following protective steps should be taken:

- empty the fuel tank; clean the oil filter and the main fuel filter;
- inject a little engine oil into the cylinders thru the spark plug holes and rotate the crankshaft by hand several times in order to spread a film of oil over the cylinder walls;
- remove the battery, store it away from frost, and recharge it once a month; never allow it to become fully discharged or plate sulfation will result;
- jack up the car, clean the tires and slightly deflate them; if tires are removed, dust them internally (and their tubes) with talcum powder; store them in a dark and airy but dry place;
- dust the seats and upholstery with moth preventive;
- cover the car with a dust sheet. To avoid serious damage to the paintwork, do not use polyvinyl-type tarpaulins.

The 12-volt electrical system is wired with protected and insulated cable in order to reduce to a minimum the risk of short circuiting. The negative battery terminal is grounded.

If any instrument fails to operate or any lamp fails to light up, first check the corresponding fuses; if the fuse is sound check to ensure that the cable terminals are tight and that the bulbs are not loose or burnt out. If the trouble persists, the electrical system should be checked by a competent auto-electrician.

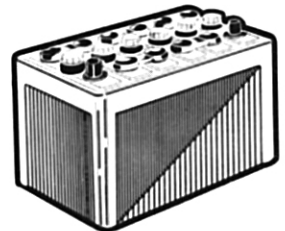

Water level

The battery water level should never be more than 3/16" above the plates and must never leave them uncovered.

When filling up the battery, use only distilled water; never add acid.

Terminals

Make sure that terminals are tight and are sufficiently coated with pure vaseline.

State of charge

The state of charge can be checked by measuring the specific gravity of the electrolyte with a suitable hydrometer.

The specific gravity/charge ratio is as follows:

specific gravity	}	1.28 (32°Bé) = charged
		1.23 (27°Bé) = half charged
		1.11 - 1.14 (15° - 18 Bé) = discharged

If distilled water has been added to a battery, the specific gravity should not be measured until mixing is complete; to facilitate mixing, charge the battery for 30 minutes.

In climates where the temperature is nearly always above 85°F, the specific gravity of the electrolyte, when the battery is fully charged, must be lower than the normal figure, viz. 1.21 (25°Bé).

BATTERY

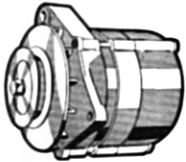
Alternator

The alternator requires some special cares.

- **It should not be tampered with.**
- Never disconnect the battery terminal of alternator-to-battery cable while the engine is running.
- When recharging the battery, completely disconnect it from the system.
- When electric weldings are carried out on car, disconnect battery making sure the positive terminal is properly insulated.
- Never reverse the battery polarity or the diodes will be damaged.
- To avoid overloading the bearings, check frequently the belt for proper tension.
- It is recommended to entrust any inspection or repair work to **Alfa Romeo Dealers.**

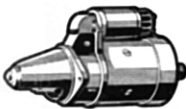
Starter

Regularly:

Inspect commutator and brushes.

The brushes must be clean and must slide freely in their holders: brush working face must be cleaned with a cloth soaked with gasoline; the brush spring must apply effective pressure.

When one brush has to be replaced, it is a good rule to replace the other at the same time. Always fit new original brushes of the prescribed type.

After replacing the brushes, run the starter with no load and for such time as is necessary to bed the brush working face to the commutator.

If the commutator is burned or elongated, it must be reworked on a lathe taking care to decrease the diameter of the minimum required only: after machining, undercut the mica between the segments.

Replacing a lamp

Headlamps

Fog lamps (Berlina & GT Veloce)

Remove the rim by pulling it off from the bottom (on Spider Veloce first loosen the screw at the lower edge of rim).

Slacken the three screws on the lens retaining ring and remove the ring.

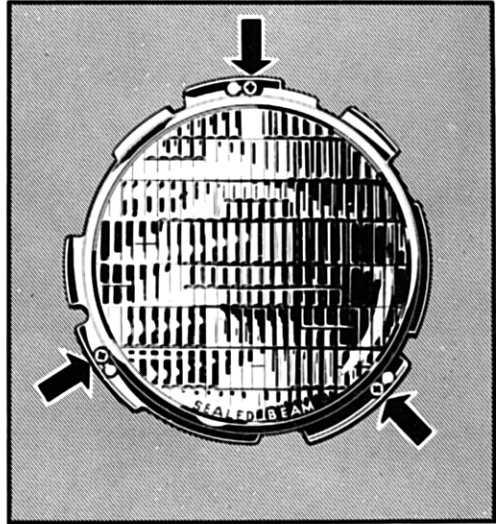

Rotate the lens unit counterclockwise and withdraw it.
Disconnect the wire junction.

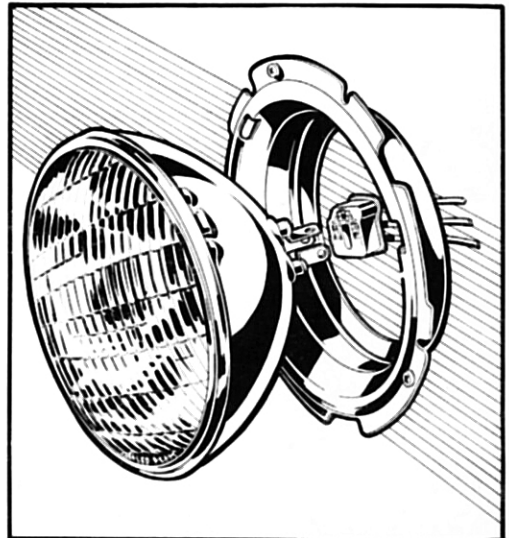

Replacing a bulb

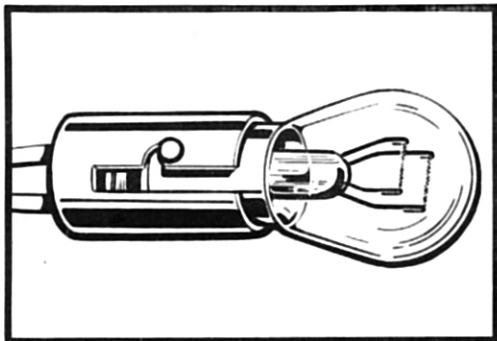

Parking & stop lights.
Direction indicators & Emergency flashers.
Back-up & license plate lights.
Loosen the attaching screws and remove the lens.

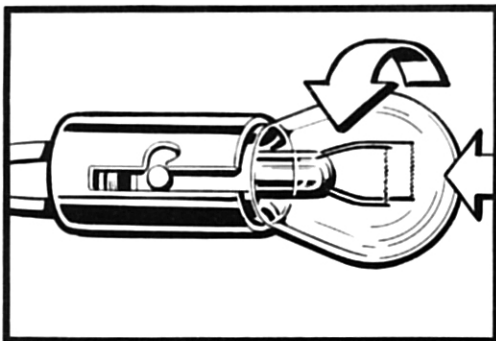

Push in the bulb and rotate counter-clockwise...

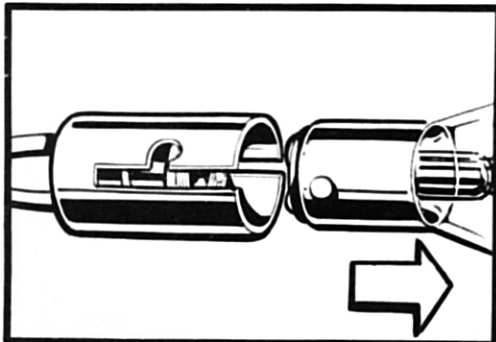

... to withdraw it.

Side marker lights

At the front, gain access to the marker lights from the bottom of fenders by removing the access port cover; at the rear, from the inside of trunk. Take out the lamp holder and withdraw the bulb.

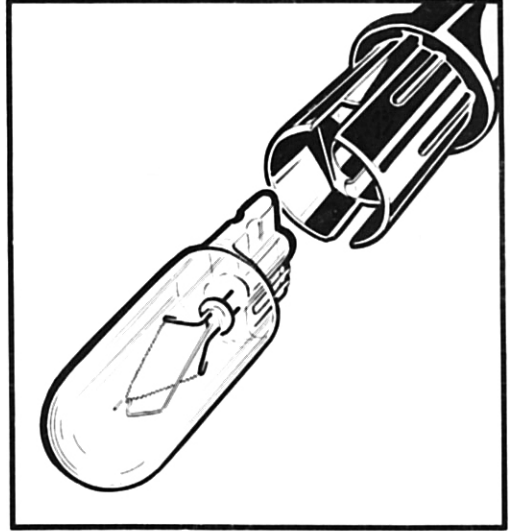

Courtesy lights

Remove the lens of dome light by loosening the screw at the side and free the bulb from the clips. On **Spider Veloce** the light is in the rearview mirror: withdraw the lens from mirror body and remove the bulb.

- Glove box light** (Spider only)
- Trunk light** (Berlina only)
- Engine compartment light.**

Free the bulb from the clips.

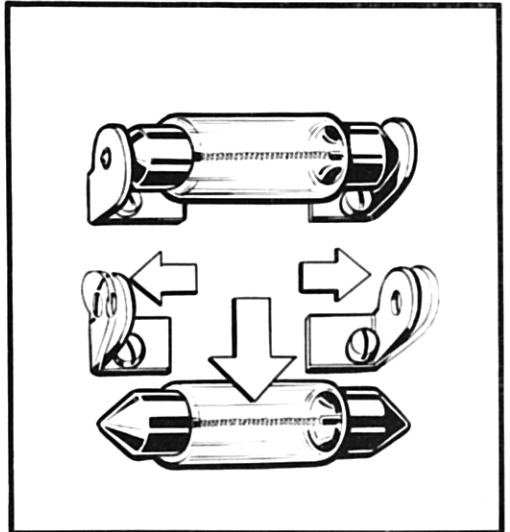

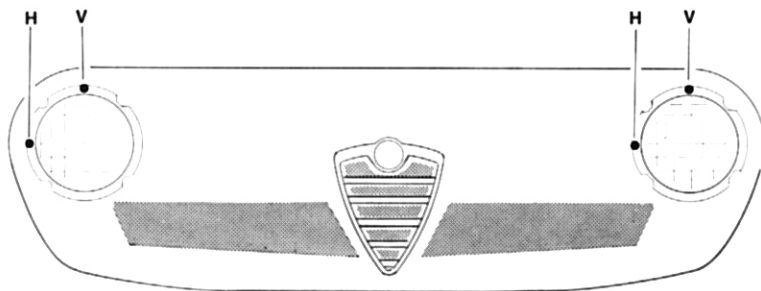
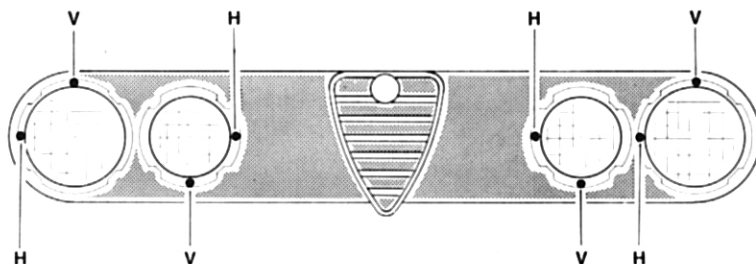

To set the headlamp beam, act properly on the adjusting screws shown in the illustration.

V Vertical adjustment

H Horizontal adjustment



WIRING DIAGRAMS

1750 BERLINA

- 1 Battery 12 V-60 Ah
- 2 Coil Bosch K12V
- 3 Ignition distributor Marelli S.103B
- 4 Starter Bosch EF(R) 12V0,7PS
- 5 Alternator Bosch K1(R,L)14V35A20
- 6 Voltage regulator Bosch AD1/14V
- 7 Windshield wiper (2 speed) Bosch WS4902AR5A(0)

- 8 Horns
- 9 Flasher unit, directional
- 10 Fuel level sender
- 11 Fusebox
- 12 Junction box
- 13 Additional fuse holder
- 14 Horn relay
- 15 Coolant thermometer bulb
- 16 Oil pressure gage sender
- 17 Low oil pressure warning sender
- 18 Cold starting device solenoid
- 19 Low fuel pressure warning sender
- 20 Service brake warning light pressure switch
- 21 Stop light pressure switch
- 22 Emergency flasher relay
- 23 Emergency flasher unit
- 24 Fog lamp relay
- 25 Blower motor (2 speed)
- 26 Cigarette lighter
- 27 Fuel pump

SWITCHES

- 28 Instrument & parking lights, headlamps and flashing
- 29 Direction indicator
- 30 Horn control
- 31 Back-up light
- 32 Windshield washer, foot operated
- 33 Blower
- 34 Fog lamp
- 35 Windshield wiper motor
- 36 Emergency flashers
- 37 Ignition and starting
- 38 Brake warning light testing
- 39 Engine compartment light
- 40 Trunk light
- 41 Dome light (microswitch on door jambs)
- 42 Dome light (toggle switch)

BULBS

- 43 Headlamp, hi/low sealed beam
- 44 Fog lamp,
- 45 Rear parking & Stop light 5/21 watts
- 46 Front direction indicators & emergency flashers
- 47 Rear direction indicators & emergency flashers 21 watts
- 48 Back-up lights
- 49 Front parking lights 5 watts
- 50 License plate light globular
- 51 Engine compartment light 5 watts
- 52 Trunk light cylindrical
- 53 Dome light
- 54 Side marker 4 watts tubular
- 55 Instrument light
- 56 Alternator warning light
- 57 Blower warning light 3 watts tubular
- 58 Parking light warning
- 59 High beam warning light
- 60 Fuel reserve warning light
- 61 Low fuel pressure warning light
- 62 Direction indicator & emergency flashers warning 1.2 watt tubular
- 63 Low oil pressure warning light
- 64 Brake warning light

CABLE COLOR CODE

- | | |
|-----------|-----------|
| AZ blue | NE black |
| BI white | RO pink |
| GI yellow | RS red |
| GR grey | VE green |
| MA brown | VI violet |

The figure following the color code on the diagram shows the wire gage in mm².

PLATE ON FUSEBOX

- 1, 2, 3 Main devices
- 4, 5 Parking lights
- 6 Indicating devices
- 7 L.H. high beam
- 8 R.H. high beam
- 9 L.H. low beam
- 10 R.H. low beam

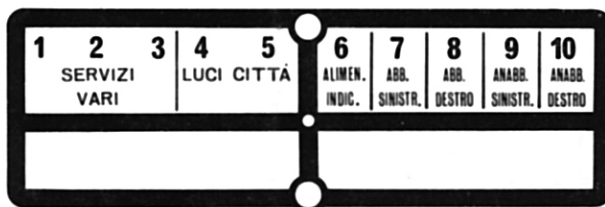

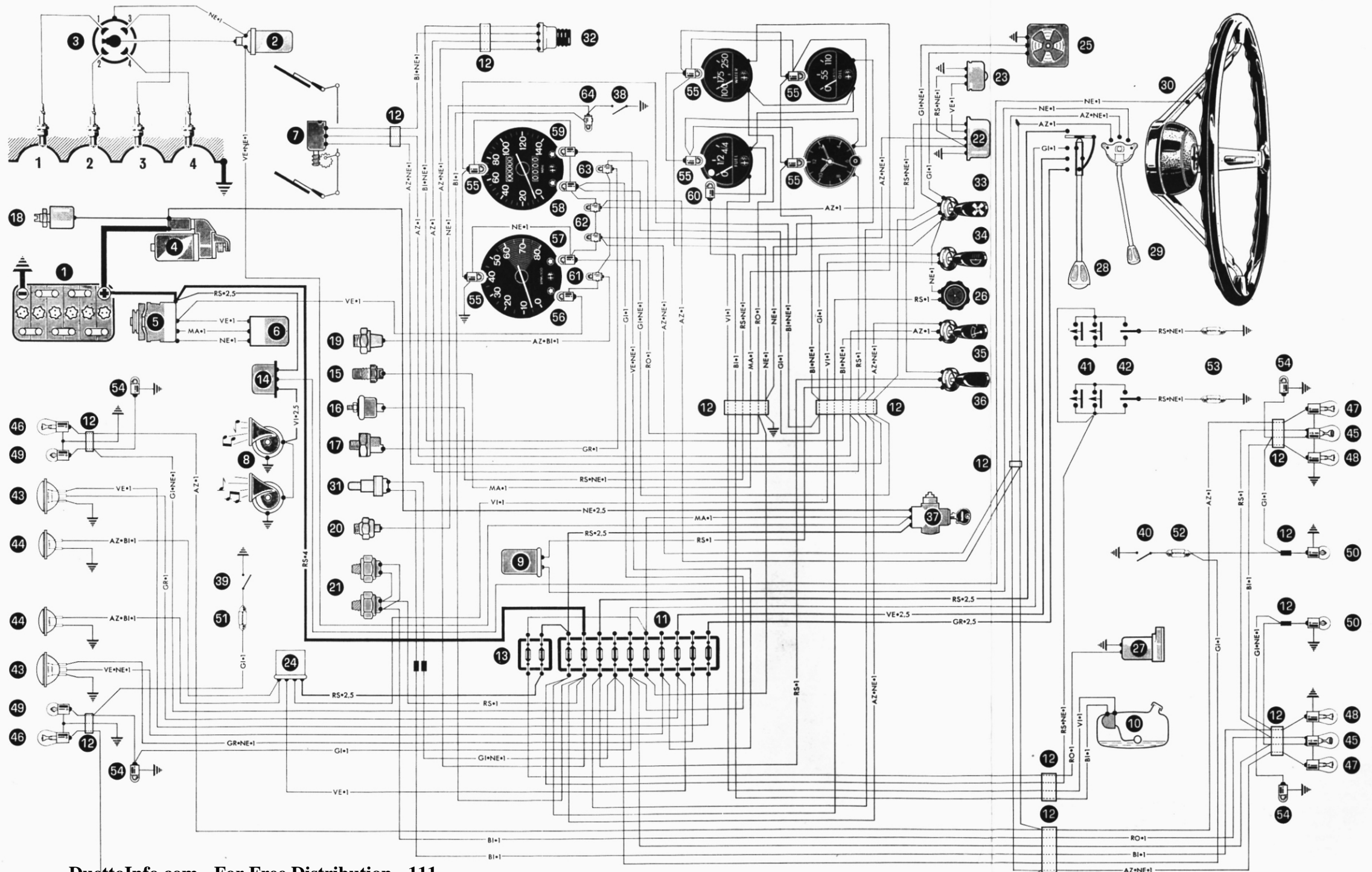

1750 GT VELOCE[®]

- 1 Battery 12 V-60 Ah
- 2 Coil Bosch K12V
- 3 Ignition distributor Marelli S.103B
- 4 Starter Bosch EF (R) 12V0,7PS
- 5 Alternator Bosch K1 (R,L) 14V35A20
- 6 Voltage regulator Bosch AD1/14V
- 7 Windshield wiper (2 speed) Bosch HA 21V

- 8 Horns
- 9 Flasher unit, directional
- 10 Fuel level sender
- 11 Fusebox
- 12 Junction box
- 13 Additional fuse holder
- 14 Horn relay
- 15 Coolant thermometer bulb
- 16 Oil pressure gage sender
- 17 Low oil pressure warning sender
- 18 Cold starting device solenoid
- 19 Low fuel pressure warning sender
- 20 Service brake warning light pressure switch
- 21 Stop light pressure switch
- 22 Emergency flasher unit
- 23 Emergency flashing light relay
- 24 Fog lamp relay
- 25 Blower motor (2 speed)
- 26 Cigarette lighter
- 27 Fuel pump

SWITCHES

- 28 Parking and dashboard lights, headlamps and flashing
- 29 Direction indicator
- 30 Horn control
- 31 Back-up lights
- 32 Windshield washer (foot operated)
- 33 Blower
- 34 Fog lamp
- 35 Windshield wiper motor (2-speed)
- 36 Emergency flashing lights
- 37 Ignition and starting
- 38 Brake warning light testing
- 39 Engine compartment light
- 40 Dome light (microswitch on door jambs)
- 41 Dome light (toggle switch)

BULBS

- 42 Headlamp hi/low sealed beam
- 43 Fog lamp
- 44 Rear parking & Stop lights 5/21 watts
- 45 Front direction indicators and emergency flashing lights)
- 46 Rear direction indicators and emergency flashing lights) 21 watts
- 47 Back-up lights
- 48 Front parking lights 5 watts
- 49 License plate light globular
- 50 Engine compartment light)
- 51 Courtesy lights 5 watts
- 52 Side marker lights 4 watts tubular cylindrical
- 53 Instrument light
- 54 Alternator warning light) 3 watts
- 55 Blower warning light tubular
- 56 Fuel reserve warning light)
- 57 Direction indicator & emergency flashing lights warning)
- 58 Low oil pressure warning light 1.2 watts
- 59 Parking light warning tubular
- 60 High beam warning light
- 61 Low fuel pressure warning light
- 62 Brake warning light

CABLE COLOR CODE

- | | |
|------------------|------------------|
| AZ blue | NE black |
| BI white | RO pink |
| GI yellow | RS red |
| GR grey | VE green |
| MA brown | VI violet |

The figure following the color code on the diagram shows the wire gage in mm².

PLATE ON FUSEBOX

- 1, 2, 3 Main devices
- 4, 5 Parking lights
- 6 Indicating devices
- 7 L.H. high beam
- 8 R.H. high beam
- 9 L.H. low beam
- 10 R.H. low beam.

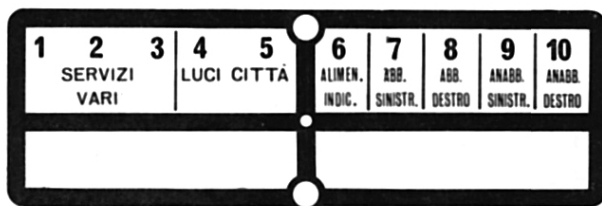

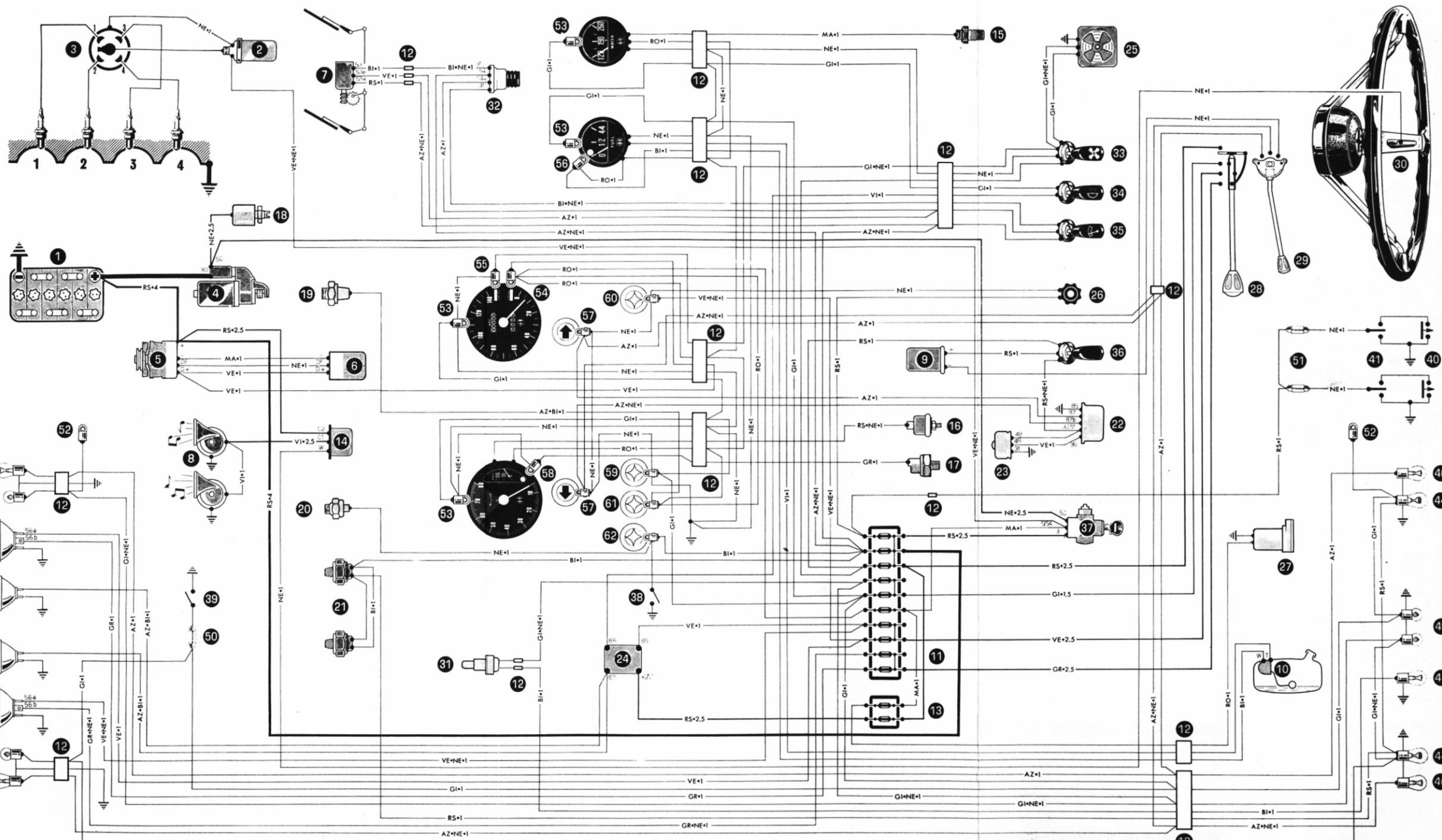

1750 SPIDER VELOCE[®]

- 1 Battery 12 V-60 Ah
- 2 Coil Bosch K12V
- 3 Ignition distributor Marelli S.103B
- 4 Starter Bosch EF(R)12V0,7PS
- 5 Alternator Bosch K1(R,L)14V35A20
- 6 Voltage regulator Bosch AD1/14V
- 7 Windshield wiper (2 speed) Bosch HA 12V
- 8 Horns
- 9 Flasher unit, directional
- 10 Fuel level sender
- 11 Fusebox
- 12 Junction box
- 13 Additional fuse holder
- 14 Horn relay
- 15 Coolant thermometer bulb
- 16 Oil pressure gage sender
- 17 Low oil pressure warning sender
- 18 Cold starting device solenoid
- 19 Low fuel pressure warning sender
- 20 Service brake warning light pressure switch
- 21 Stop light pressure switch
- 22 Emergency flasher unit
- 23 Emergency flashing light relay
- 24 Blower motor (2 speed)
- 25 Cigarette lighter
- 26 Fuel pump

SWITCHES

- 27 Parking lights, headlamps and flashing
- 28 Direction indicator
- 29 Horn control
- 30 Back-up lights
- 31 Windshield washer, foot operated
- 32 Ignition and starting
- 33 Dashboard light
- 34 Blower
- 35 Windshield wiper motor (2-speed)
- 36 Emergency flashing lights
- 37 Brake warning light testing
- 38 Engine compartment light
- 39 Dome light (microswitch on door jambs)
- 40 Courtesy light* (toggle switch in light unit)
- 41 Glove box light

BULBS

- 42 Headlamp hi/low sealed beam
- 43 Parking & Stop lights 5/21 watts
- 44 Front direction indicators and emergency flashing lights)
- 45 Rear direction indicators and emergency flashing lights) 21 watts
- 46 Back-up lights)
- 47 Front parking lights 5 watts
- 48 License plate light globular
- 49 Engine compartment light 5 watts
- 50 Courtesy light cylindrical
- 51 Glove box light)
- 52 Side marker light 4 watts tubular
- 53 Ash tray light 3 watts cylindrical
- 54 Instrument light)
- 55 Alternator warning light) 3 watts tubular
- 56 Blower warning light)
- 57 Fuel reserve warning light)
- 58 Direction indicator & emergency flashers warning)
- 59 Low oil pressure warning light) 1.2 watt tubular
- 60 Parking light warning)
- 61 High beam warning light)
- 62 Low fuel pressure warning light)
- 63 Brake warning light)

CABLE COLOR CODE

- | | | | |
|----|--------|----|--------|
| AZ | blue | NE | black |
| BI | white | RO | pink |
| GI | yellow | RS | red |
| GR | grey | VE | green |
| MA | brown | VI | violet |

The figure following the color code on the diagram shows the wire gage in mm².

PLATE ON FUSEBOX

- 1, 2, 3 Main devices
- 4, 5 Parking lights
- 6 Indicating devices
- 7 L.H. high beam
- 8 R.H. high beam
- 9 L.H. low beam
- 10 R.H. low beam

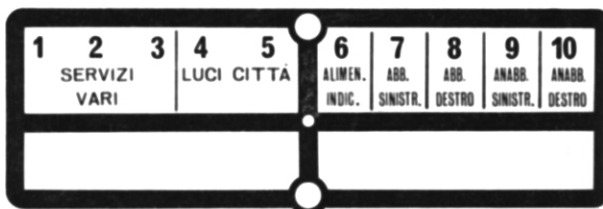

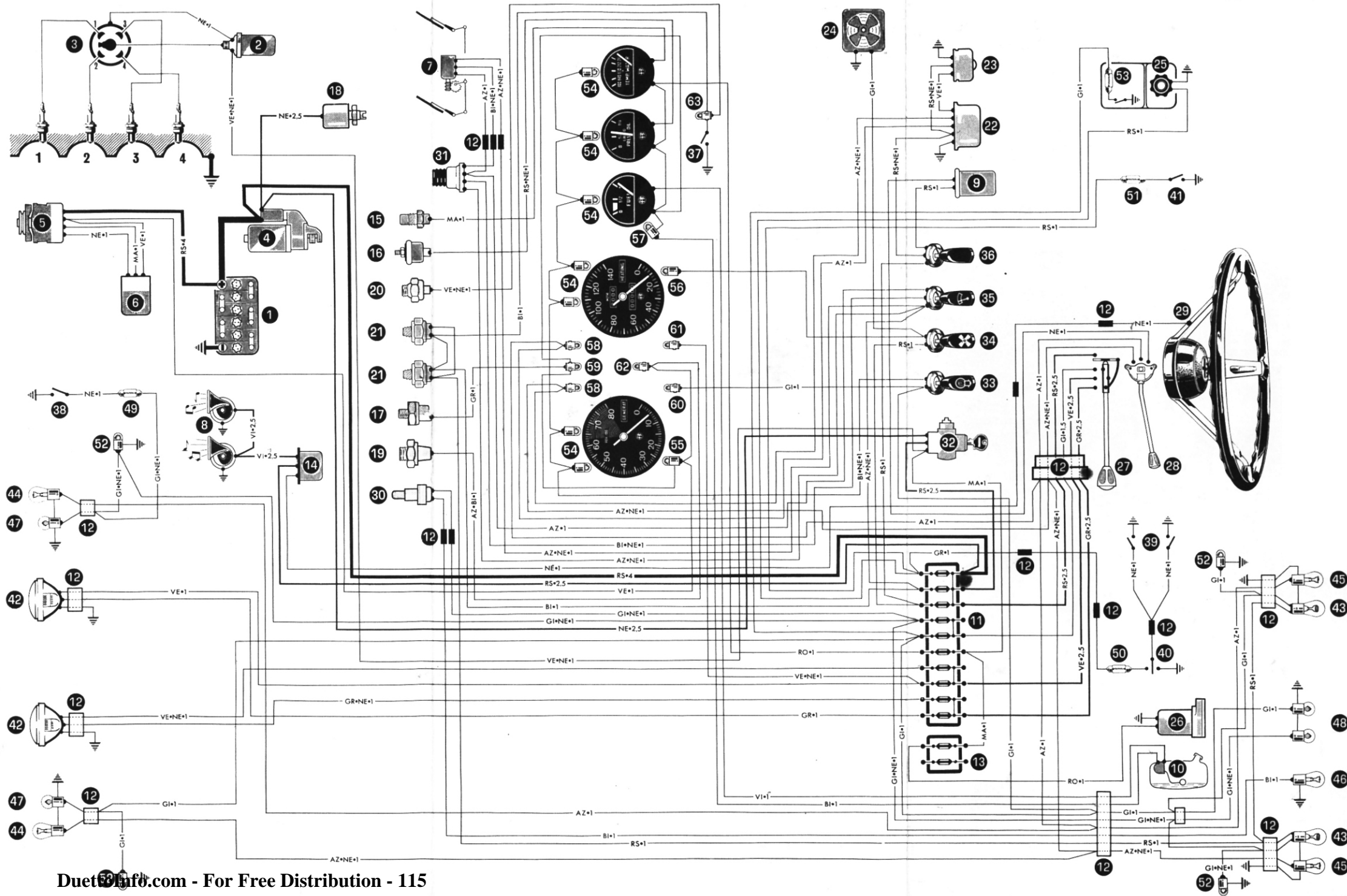

In the trunk there are:

- Spare tire under the mat



- Jack



- Tool kit, containing:

- Tommy bar for plug spanner
- Box spanner for plugs
- Pliers
- Screwdriver
- Phillips screwdriver
- Wheel brace

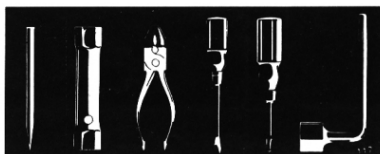

Alfa Romeo Via Gattamelata, 45 - 20149 MILANO

DIASS - Pubblicazione 1386 - 10/68 - 3000
Printed in Italy - arti grafiche milanesi - Stampato su carta BURGO SOLEX da gr. 200 e 96 al mq.
